



# Complete protection and safety made easy

System pro *M* portfolio  
of DIN rail devices



- Safety and reliability at its best
- One portfolio – easy selection
- Uncompromised fulfilling of local requirements
- Technology leadership

—  
**The System pro *M* portfolio offers a complete solution of line protection, designed to work across all applications; delivering an uncompromised level of performance and safety.**

**This series of devices including Miniature Circuit Breaker (MCB), Residual Current Circuit Breaker (RCCB) and Switch Disconnectors are fully ISI certified and innovated with the same expertise and technological know-how as the original MCB first invented by ABB almost one hundred years ago.**

**System pro *M* portfolio is an easy choice, thanks to its compact portfolio, simplified yet intuitive design and full functionality. Furthermore, this universal range of products compliments a wide assortment of accessories that cater to the residential, commercial, industrial and OEM markets.**

---

# Table of contents

<b>4–8</b>	<b>Introduction</b>
<b>9–11</b>	<b>Portfolio overview</b>
<b>12–21</b>	<b>Miniature Circuit Breaker (MCB)– SB200 M</b>
<b>22–26</b>	<b>Residual Current Circuit Breaker (RCCB)– FB200</b>
<b>28–32</b>	<b>Residual Current Circuit Breaker with overcurrent protection (RCBO)– DS201 M</b>
<b>34–38</b>	<b>Switch Disconnecter– SDB200</b>
<b>40–46</b>	<b>Miniature Circuit Breaker– SB200 DC</b>
<b>47–51</b>	<b>Accessories</b>
<b>52–61</b>	<b>Auxiliary elements</b>
<b>63–69</b>	<b>Co-ordination tables</b>
<b>70–71</b>	<b>Wiring diagram</b>
<b>72</b>	<b>Overall dimensions</b>
<b>73–77</b>	<b>Related offering– Overvoltage protection Circuit Monitoring System (CMS)</b>





---

SYSTEM PRO M PORTFOLIO

Designed to work across all applications; delivering an uncompromised level of performance and safety in residential, commercial and industrial applications.

# Performance and safety

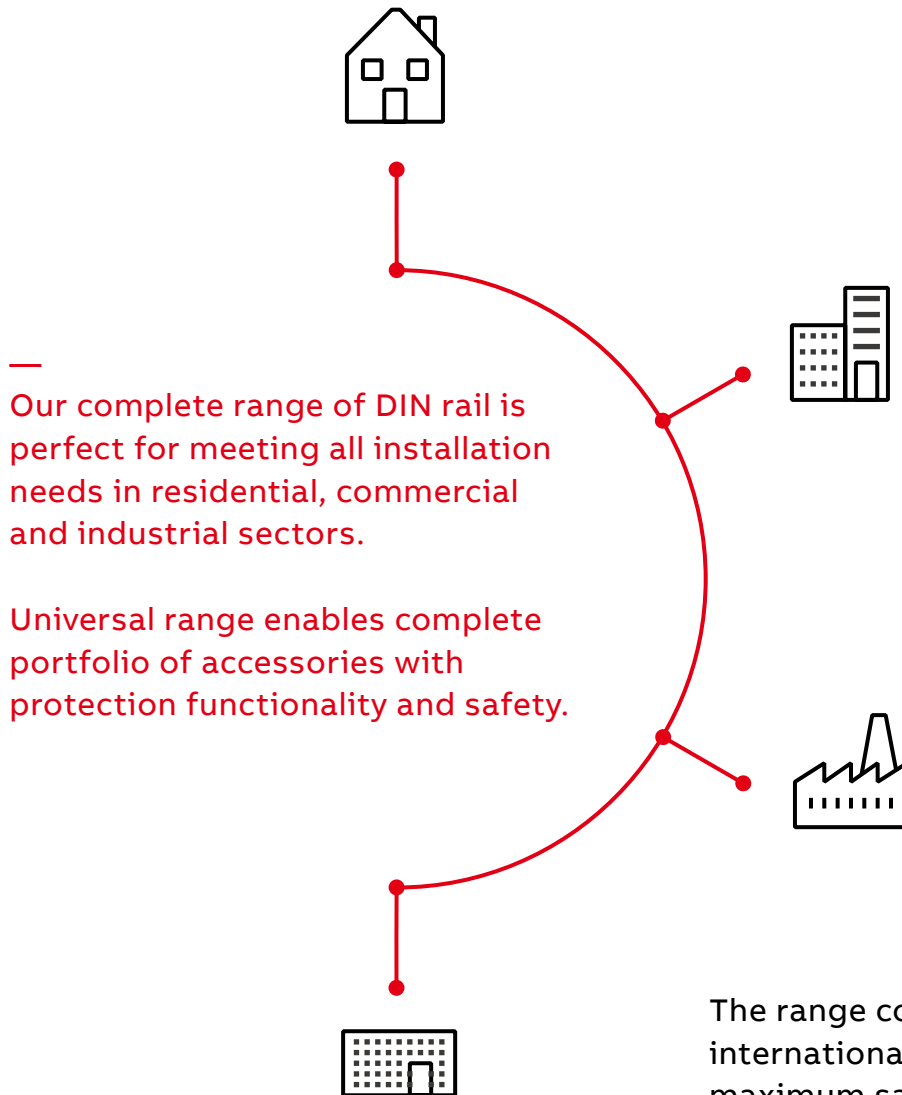

Our complete range of DIN rail is perfect for meeting all installation needs in residential, commercial and industrial sectors.

Universal range enables complete portfolio of accessories with protection functionality and safety.

The range complies with relevant international standards. Ensuring maximum safety to the household and complete protection to the electrical installation.

MCBs comply to IEC/EN 60898-1 and IEC/EN 60947-2 and carry all relevant approval marks for each market and segment they are destined to.

This range is designed to meet the needs of distribution and protection of electricity.

—  
01



—  
02



—  
01  
Industrial  
—  
02  
Commercial  
—  
03  
Residential



—  
03

# Value Proposition

## Complete protection and safety made easy



### Safety and reliability at its best

- Protection from over-currents, earth leakage, accidental electric shock and earth fault currents
- Guaranteed safety and reliability, thanks to multiple automated testing of each single product



### Uncompromised fulfilling of local requirements

- ISI approval for the whole range

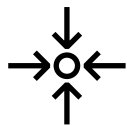

### One portfolio – easy selection

- Single and complete portfolio with a high rated voltage (240/415 V)
- Covering requirements for residential, commercial and industrial installations
- Easy selection of products

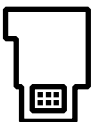

### Technology leadership

- Original technology invented and established by ABB
- Patented in 1924 and continuously further improving the technology

The System pro *M* portfolio offers a complete solution of line protection, designed to work across all applications; delivering an uncompromised level of performance and safety.

This series of devices including Miniature Circuit Breaker (MCB), Residual Current Circuit Breaker (RCCB) and Isolator is fully ISI certified and innovated with the same expertise and technological know-how as the original MCB first invented by ABB almost one hundred years ago.

System pro *M* portfolio is an easy choice, thanks to its compact portfolio, simplified yet intuitive design and full functionality. Furthermore, this universal range of products compliments a wide assortment of accessories that cater to the residential, commercial, industrial and OEM markets.

---

# Complete portfolio

## System pro *M*

- 
- Portfolio overview
  - Technical data
  - Ordering data

# System pro M

## Portfolio overview

With the ABB System pro M portfolio, we offer a complete system solution including MCBs, RCCBs, RCBOs, SDs, busbars accessories and consumer units.

### MCB – Miniature Circuit Breaker

- Protect installations against overloads and short-circuit, guaranteeing reliability and safety of operations
- SB200 M MCB with breaking capacity of 10kA
- B characteristic, 1/2/1P+N pole configurations in all sizes up to 40A.
- C characteristic in 1/2/3/4/1P+N/3P+N Pole configurations in all sizes up to 63A
- D characteristic in 1/2/3/4 Pole configurations in all sizes up to 63A

### RCCB – Residual Current Circuit Breaker

- Sensitive only to earth fault current, therefore they have to be connected in series with a MCB or a fuse to protect them against over-currents and short-circuits
- FB200 RCCB with sensitivity 30/100/300mA in AC type and 2/4P configuration up to 63A, corresponding to all requirements in residential applications

### RCBO

- Combined protection against both earth-fault currents and overloads or short-circuits in one single device
- DS201 M RCBO with breaking capacity 10kA
- C characteristics, AC and APR types, 30/100/300mA sensitivity and 2P+N configuration up to 40A

### SD – Switch disconnecter

- Opening a disconnecter ensures isolation of downstream circuit
- SDB200 with 2/3/4P configurations in all sizes up to 63A

### Accessories

- Busbar with 12/56/57 pins in 1/2/3/4P to ensure easy and reliable wiring

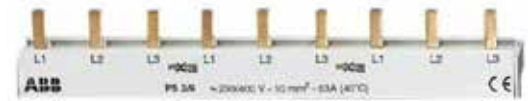

Busbar



S2C-H6-...  
Auxiliary contact



S2C-S/H6R  
Signal/ Auxiliary contacts



S2C-A  
Shunt trip



MCB



RCCB



RCBO



SD



—  
ABB ITUS distribution enclosures

## A collaborative effort

### Meeting the right requirements

ABB ITUS series Distribution Enclosures put no limits to your imagination. Gone are the days when enclosures were meant only for archaic needs. With the ABB ITUS series enclosures, you can rest assured that it will not only perform at its peak, but also blend in with the rest of your interiors. Using ABB's innovative designs, domain expertise and standards, ABB ITUS is ready to help you to be today's trendsetter.



—  
SPN



—  
SPN



—  
TPN



—  
TPN-SH PPI



—  
TPN-SV DB

# Miniature Circuit Breaker SB200 M

## The details make the difference

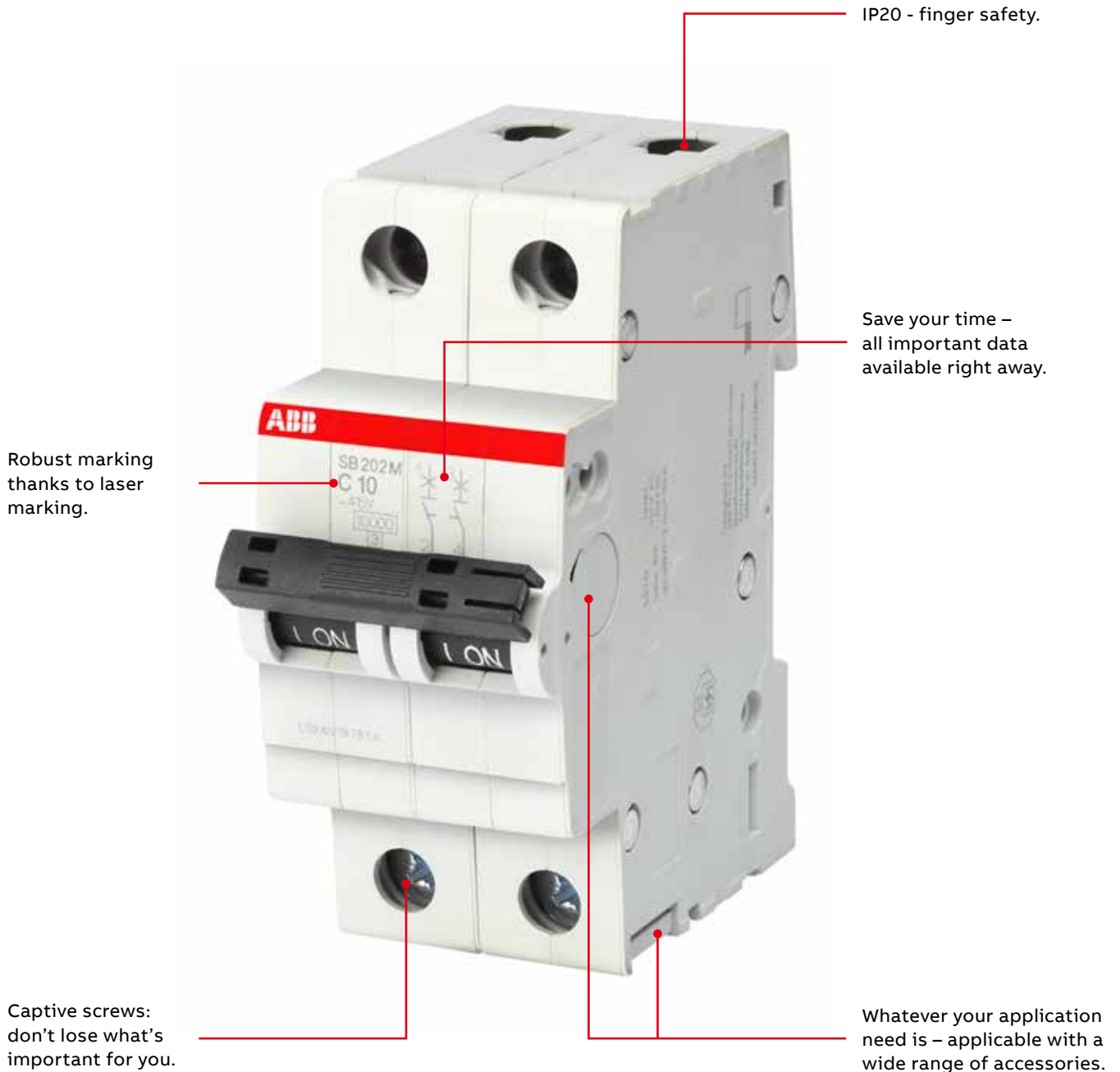



### State-of-the-art design (Aesthetics & Ergonomics)

Elegant in appearance. Knob designed for easy operation.



### Laser marking

All printing of the SB200 M MCBs, like the approvals on the product identification, are printed by a laser. Laser printing ensures a friction, scratch and solvent resistant marking on the MCBs. Easy identification of the products in case of maintenance or replacement, due to safe laser printing.



### Housing cover with fire retardant material

High performance 100% recyclable plastic material with fire retardant, high melting point, low water absorption & high dielectric strength properties. ABB is taking care of the environment... with the latest generation of thermoplastics, it is possible to recycle the MCBs – especially the thermoplastic housing material can be re-used. SB200 is 100% free of halogens.



### IP20 protection

IP 20 - finger safe terminals. The System pro M compact® MCBs are equipped with 25 mm<sup>2</sup> cylinder lift twin terminals, a well-proven and reliable technology - designed for sophisticated industrial use. The cross wiring can easily be done by inserting the System pro M compact® busbars into the rear terminal part and then the incoming wires into the front part of the terminal.



### Labelling area

Provision for providing label enables easy identification of circuit during installation, operation & maintenance.



### Accessories mountable

Wide range of add-on accessories having 30 different types of accessories. Max possibility of Mounting: 4 different accessories on the right side and 1 on the left side ensures highest flexibility of functions. Universal contact, motorised unique accessory like mechanical tripping devices available only with ABB.

## Miniature Circuit Breaker SB200 M

### Technical data



General data	
Standards	IS/IEC 60898-1
Poles	B: 1P, 1P+N, 2P C: 1P, 2P, 3P, 4P, 1P+N, 3P+N D: 1P, 2P, 3P, 4P
Rated short-circuit capacity (I <sub>cn</sub> )	10 kA
Rated ultimate short-circuit breaking capacity I <sub>cu</sub> (acc.to IEC 60947-2)	15 kA
Tripping characteristics	B, C, D
Reference temperature for tripping characteristics	30°C
Energy limiting class (B-,C- Curve)	3
Rated voltage U <sub>e</sub>	1P : 240/415 V AC 1P + N : 240 V AC 2...4P : 415 V AC 3P + N : 415 V AC
Rated current I <sub>n</sub>	B: 6, 10, 16, 20, 25, 32, 40 A C&D: 0,5, 1, 1,6, 2, 3, 4, 6, 10, 16, 20, 25, 32, 40, 50, 63 A
Rated frequency	50 Hz
Max. Power frequency recovery voltage (U <sub>max</sub> )	1P: 264 V AC; 60V DC; 1P+N:264 V AC; 2...4P : 457 V AC; 2P: 120V DC; 3P+N: 457 V AC
Min. operating voltage	12 V AC
Rated insulation voltage U <sub>i</sub> acc. to IEC/EN 60664-1	250 V AC (phase to ground) , 440 V AC (phase to phase)
Rated impulse withstand voltage U <sub>imp</sub> . (1.2/50μs)	4 kV (test voltage 6.2kV at sea level, 5kV at 2.000m)
Dielectric test voltage	2 kV (50 / 60Hz, 1 min.)
Overvoltage category	III
Pollution degree	2
Electrical endurance	I <sub>n</sub> < 32A: 20.000 ops.(AC), I <sub>n</sub> ≥ 32A: 10.000 ops.(AC); 1.000 ops. (DC); 1 cycle (2s - ON, 13s - OFF, I <sub>n</sub> ≤ 32A), 1 cycle (2s - ON, 28s - OFF, I <sub>n</sub> >32A)
Mechanical data	
Housing	Insulation group II
Toggle	Insulation group II, black, sealable
Contact position indication	White Marking on toggle ( I ON / O OFF )
Protection degree acc. to EN 60529	IP20, IP40 in enclosure with cover
Mechanical endurance	20.000 ops.
Shock resistance acc. to IEC/EN 60068-2-27	25 g - 2 shocks - 13 ms
Vibration resistance acc. to IEC/EN 60068-2-6	5g - 20 cycles at 5...150...5 Hz with load 0.8I <sub>n</sub>
Environmental conditions (damp heat) acc. to IEC/EN 60068-2-30	28 cycles with 55°C/90-96% and 25°C/95-100%
Ambient temperature	-25 ... +55°C
Storage temperature	-40 ... +70°C

<b>Installation</b>	
Terminal	Cage terminal
Cross-section of conductors (top / bottom) Solid, Stranded	25 mm <sup>2</sup> / 25 mm <sup>2</sup>
Flexible	16 mm <sup>2</sup> / 16 mm <sup>2</sup>
Cross-section of busbars (top / bottom)	10 mm <sup>2</sup>
Tightening torque	2 Nm
Screwdriver	No. 2 Pozidrive
Mounting	On DIN rail 35 mm acc. to EN 60715 by fast clip
Mounting position	Any
Supply	Optional
<b>Dimensions and weight</b>	
Mounting dimensions acc. to DIN 43880	Mounting dimension 1
Pole dimensions (H x D x W)	85 x 69 x 17.5 mm
Pole weight	ca. 115 g
<b>Combination with aux. elements</b>	
Auxiliary contact	yes
Signal contact	yes
Shunt trip	yes
Undervoltage release	yes
Overvoltage release	yes
Rotary handle	yes
Mechanical tripping device	yes
Padlock enabled	yes
Motor operating device	yes
<b>Approvals</b>	
ISI approved	yes

## MCB SB200 M B characteristic

### Ordering data



SB201 M B 16

#### SB200 M B characteristic

Function: protection and control of the circuits against overloads and short-circuits; protection for resistive and inductive loads with low inrush current.

Applications: residential, commercial and industrial

Standard: IEC/IS 60898-1, IEC/IS 60947-2

Icn=10 kA

#### SB201 M B

Number of poles	Rated current	Order details		Weight 1 piece	Pack unit
		In A	Type code		
1P	6 A	SB201 M-B6	1SYS271012R0065	0.115	12
	10 A	SB201 M-B10	1SYS271012R0105	0.115	12
	16 A	SB201 M-B16	1SYS271012R0165	0.115	12
	20 A	SB201 M-B20	1SYS271012R0205	0.115	12
	25 A	SB201 M-B25	1SYS271012R0255	0.115	12
	32 A	SB201 M-B32	1SYS271012R0325	0.115	12
	40 A	SB201 M-B40	1SYS271012R0405	0.115	12

#### SB201 M B NA

Number of poles	Rated current	Order details		Weight 1 piece	Pack unit
		In A	Type code		
1P+N	6 A	SB201 M-B6 NA	1SYS271112R0065	0.195	6
	10 A	SB201 M-B10 NA	1SYS271112R0105	0.195	6
	16 A	SB201 M-B16 NA	1SYS271112R0165	0.195	6
	20 A	SB201 M-B20 NA	1SYS271112R0205	0.195	6
	25 A	SB201 M-B25 NA	1SYS271112R0255	0.195	6
	32 A	SB201 M-B32 NA	1SYS271112R0325	0.195	6
	40 A	SB201 M-B40 NA	1SYS271112R0405	0.195	6

#### SB202 M B

Number of poles	Rated current	Order details		Weight 1 piece	Pack unit
		In A	Type code		
2P	6 A	SB202 M-B6	1SYS272012R0065	0.235	6
	10 A	SB202 M-B10	1SYS272012R0105	0.235	6
	16 A	SB202 M-B16	1SYS272012R0165	0.235	6
	20 A	SB202 M-B20	1SYS272012R0205	0.235	6
	25 A	SB202 M-B25	1SYS272012R0255	0.235	6
	32 A	SB202 M-B32	1SYS272012R0325	0.235	6
	40 A	SB202 M-B40	1SYS272012R0405	0.235	6

## MCB SB200 M C characteristic

### Ordering data



SB201 M C 16

#### SB200 M C characteristic

Function: protection and control of the circuits against overloads and short-circuits; protection for resistive and inductive loads with low inrush current.

**Applications: residential, commercial and industrial**

**Standard: IEC/EN 60898-1, IEC/EN 60947-2**

**Icn=10 kA**

#### SB201 M C

Number of poles	Rated current	Order details		Weight 1 piece	Pack unit
		In A	Type code		
1P	0.5 A	SB201 M-C0.5	1SYS271012R0984	0.115	12
	1 A	SB201 M-C1	1SYS271012R0014	0.115	12
	1.6 A	SB201 M-C1.6	1SYS271012R0974	0.115	12
	2 A	SB201 M-C2	1SYS271012R0024	0.115	12
	3 A	SB201 M-C3	1SYS271012R0034	0.115	12
	4 A	SB201 M-C4	1SYS271012R0044	0.115	12
	6 A	SB201 M-C6	1SYS271012R0064	0.115	12
	10 A	SB201 M-C10	1SYS271012R0104	0.115	12
	16 A	SB201 M-C16	1SYS271012R0164	0.115	12
	20 A	SB201 M-C20	1SYS271012R0204	0.115	12
	25 A	SB201 M-C25	1SYS271012R0254	0.115	12
	32 A	SB201 M-C32	1SYS271012R0324	0.115	12
	40 A	SB201 M-C40	1SYS271012R0404	0.115	12
	50 A	SB201 M-C50	1SYS271012R0504	0.115	12
	63 A	SB201 M-C63	1SYS271012R0634	0.115	12

#### SB201 M C NA

Number of poles	Rated current	Order details		Weight 1 piece	Pack unit
		In A	Type code		
1P+N	0.5 A	SB201 M-C0.5 NA	1SYS271112R0984	0.195	6
	1 A	SB201 M-C1 NA	1SYS271112R0014	0.195	6
	1.6 A	SB201 M-C1.6 NA	1SYS271112R0974	0.195	6
	2 A	SB201 M-C2 NA	1SYS271112R0024	0.195	6
	3 A	SB201 M-C3 NA	1SYS271112R0034	0.195	6
	4 A	SB201 M-C4 NA	1SYS271112R0044	0.195	6
	6 A	SB201 M-C6 NA	1SYS271112R0064	0.195	6
	10 A	SB201 M-C10 NA	1SYS271112R0104	0.195	6
	16 A	SB201 M-C16 NA	1SYS271112R0164	0.195	6
	20 A	SB201 M-C20 NA	1SYS271112R0204	0.195	6
	25 A	SB201 M-C25 NA	1SYS271112R0254	0.195	6
	32 A	SB201 M-C32 NA	1SYS271112R0324	0.195	6
	40 A	SB201 M-C40 NA	1SYS271112R0404	0.195	6
	50 A	SB201 M-C50 NA	1SYS271112R0504	0.195	6
	63 A	SB201 M-C63 NA	1SYS271112R0634	0.195	6

## MCB SB200 M C characteristic

### Ordering data



SB202 M C 16

#### SB202 M C

Number of poles	Rated current	Order details		Weight 1 piece	Pack unit
		In A	Type code		
2P	0.5 A	SB202 M-C0.5	1SYS272012R0984	0.235	6
	1 A	SB202 M-C1	1SYS272012R0014	0.235	6
	1.6 A	SB202 M-C1.6	1SYS272012R0974	0.235	6
	2 A	SB202 M-C2	1SYS272012R0024	0.235	6
	3 A	SB202 M-C3	1SYS272012R0034	0.235	6
	4 A	SB202 M-C4	1SYS272012R0044	0.235	6
	6 A	SB202 M-C6	1SYS272012R0064	0.235	6
	10 A	SB202 M-C10	1SYS272012R0104	0.235	6
	16 A	SB202 M-C16	1SYS272012R0164	0.235	6
	20 A	SB202 M-C20	1SYS272012R0204	0.235	6
	25 A	SB202 M-C25	1SYS272012R0254	0.235	6
	32 A	SB202 M-C32	1SYS272012R0324	0.235	6
	40 A	SB202 M-C40	1SYS272012R0404	0.235	6
	50 A	SB202 M-C50	1SYS272012R0504	0.235	6
	63 A	SB202 M-C63	1SYS272012R0634	0.235	6

#### SB203 M C

Number of poles	Rated current	Order details		Weight 1 piece	Pack unit
		In A	Type code		
3P	0.5 A	SB203 M-C0.5	1SYS273012R0984	0.355	4
	1 A	SB203 M-C1	1SYS273012R0014	0.355	4
	1.6 A	SB203 M-C1.6	1SYS273012R0974	0.355	4
	2 A	SB203 M-C2	1SYS273012R0024	0.355	4
	3 A	SB203 M-C3	1SYS273012R0034	0.355	4
	4 A	SB203 M-C4	1SYS273012R0044	0.355	4
	6 A	SB203 M-C6	1SYS273012R0064	0.355	4
	10 A	SB203 M-C10	1SYS273012R0104	0.355	4
	16 A	SB203 M-C16	1SYS273012R0164	0.355	4
	20 A	SB203 M-C20	1SYS273012R0204	0.355	4
	25 A	SB203 M-C25	1SYS273012R0254	0.355	4
	32 A	SB203 M-C32	1SYS273012R0324	0.355	4
	40 A	SB203 M-C40	1SYS273012R0404	0.355	4
	50 A	SB203 M-C50	1SYS273012R0504	0.355	4
	63 A	SB203 M-C63	1SYS273012R0634	0.355	4

## MCB SB200 M C characteristic

### Ordering data



SB204 M C 16

#### SB203 M C NA

Number of poles	Rated current	Order details		Weight 1 piece	Pack unit
		In A	Type code		
3P+N	0.5 A	SB203 M-C0.5 NA	1SYS273112R0984	0.425	3
	1 A	SB203 M-C1 NA	1SYS273112R0014	0.425	3
	1.6 A	SB203 M-C1.6 NA	1SYS273112R0974	0.425	3
	2 A	SB203 M-C2 NA	1SYS273112R0024	0.425	3
	3 A	SB203 M-C3 NA	1SYS273112R0034	0.425	3
	4 A	SB203 M-C4 NA	1SYS273112R0044	0.425	3
	6 A	SB203 M-C6 NA	1SYS273112R0064	0.425	3
	10 A	SB203 M-C10 NA	1SYS273112R0104	0.425	3
	16 A	SB203 M-C16 NA	1SYS273112R0164	0.425	3
	20 A	SB203 M-C20 NA	1SYS273112R0204	0.425	3
	25 A	SB203 M-C25 NA	1SYS273112R0254	0.425	3
	32 A	SB203 M-C32 NA	1SYS273112R0324	0.425	3
	40 A	SB203 M-C40 NA	1SYS273112R0404	0.425	3
	50 A	SB203 M-C50 NA	1SYS273112R0504	0.425	3
	63 A	SB203 M-C63 NA	1SYS273112R0634	0.425	3

#### SB204 M C

Number of poles	Rated current	Order details		Weight 1 piece	Pack unit
		In A	Type code		
4P	0.5 A	SB204 M-C0.5	1SYS274012R0984	0.465	3
	1 A	SB204 M-C1	1SYS274012R0014	0.465	3
	1.6 A	SB204 M-C1.6	1SYS274012R0974	0.465	3
	2 A	SB204 M-C2	1SYS274012R0024	0.465	3
	3 A	SB204 M-C3	1SYS274012R0034	0.465	3
	4 A	SB204 M-C4	1SYS274012R0044	0.465	3
	6 A	SB204 M-C6	1SYS274012R0064	0.465	3
	10 A	SB204 M-C10	1SYS274012R0104	0.465	3
	16 A	SB204 M-C16	1SYS274012R0164	0.465	3
	20 A	SB204 M-C20	1SYS274012R0204	0.465	3
	25 A	SB204 M-C25	1SYS274012R0254	0.465	3
	32 A	SB204 M-C32	1SYS274012R0324	0.465	3
	40 A	SB204 M-C40	1SYS274012R0404	0.465	3
	50 A	SB204 M-C50	1SYS274012R0504	0.465	3
	63 A	SB204 M-C63	1SYS274012R0634	0.465	3

## MCB SB200 M D characteristic

### Ordering data

#### SB200 M D characteristic

Function: protection and control of the circuits against overloads and short-circuits; protection for resistive and inductive loads with low inrush current.

Applications: residential, commercial and industrial

Standard: IEC/EN 60898-1, IEC/EN 60947-2

Icn=10 kA



SB202 M D 16

#### SB201 M D

Number of poles	Rated current	Order details		Weight 1 piece	Pack unit
		In A	Type code		
1P	0.5 A	SB201 M-D0,5	1SYS271012R0981	0.115	12
	1 A	SB201 M-D1	1SYS271012R0011	0.115	12
	1.6 A	SB201 M-D1,6	1SYS271012R0971	0.115	12
	2 A	SB201 M-D2	1SYS271012R0021	0.115	12
	3 A	SB201 M-D3	1SYS271012R0031	0.115	12
	4 A	SB201 M-D4	1SYS271012R0041	0.115	12
	6 A	SB201 M-D6	1SYS271012R0061	0.115	12
	10 A	SB201 M-D10	1SYS271012R0101	0.115	12
	16 A	SB201 M-D16	1SYS271012R0161	0.115	12
	20 A	SB201 M-D20	1SYS271012R0201	0.115	12
	25 A	SB201 M-D25	1SYS271012R0251	0.115	12
	32 A	SB201 M-D32	1SYS271012R0321	0.115	12
	40 A	SB201 M-D40	1SYS271012R0401	0.115	12
	50 A	SB201 M-D50	1SYS271012R0501	0.115	12
	63 A	SB201 M-D63	1SYS271012R0631	0.115	12

#### SB202 M D

Number of poles	Rated current	Order details		Weight 1 piece	Pack unit
		In A	Type code		
2P	0.5 A	SB202 M-D0.5	1SYS272012R0981	0.235	6
	1 A	SB202 M-D1	1SYS272012R0011	0.235	6
	1.6 A	SB202 M-D1.6	1SYS272012R0971	0.235	6
	2 A	SB202 M-D2	1SYS272012R0021	0.235	6
	3 A	SB202 M-D3	1SYS272012R0031	0.235	6
	4 A	SB202 M-D4	1SYS272012R0041	0.235	6
	6 A	SB202 M-D6	1SYS272012R0061	0.235	6
	10 A	SB202 M-D10	1SYS272012R0101	0.235	6
	16 A	SB202 M-D16	1SYS272012R0161	0.235	6
	20 A	SB202 M-D20	1SYS272012R0201	0.235	6
	25 A	SB202 M-D25	1SYS272012R0251	0.235	6
	32 A	SB202 M-D32	1SYS272012R0321	0.235	6
	40 A	SB202 M-D40	1SYS272012R0401	0.235	6
	50 A	SB202 M-D50	1SYS272012R0501	0.235	6
	63 A	SB202 M-D63	1SYS272012R0631	0.235	6

## MCB SB200 M D characteristic

### Ordering data



SB203 M D 16

#### SB203 M D

Number of poles	Rated current	Order details		Weight 1 piece	Pack unit
		In A	Type code		
3P	0.5 A	SB203 M-D0.5	1SYS273012R0981	0.355	4
	1 A	SB203 M-D1	1SYS273012R0011	0.355	4
	1.6 A	SB203 M-D1.6	1SYS273012R0971	0.355	4
	2 A	SB203 M-D2	1SYS273012R0021	0.355	4
	3 A	SB203 M-D3	1SYS273012R0031	0.355	4
	4 A	SB203 M-D4	1SYS273012R0041	0.355	4
	6 A	SB203 M-D6	1SYS273012R0061	0.355	4
	10 A	SB203 M-D10	1SYS273012R0101	0.355	4
	16 A	SB203 M-D16	1SYS273012R0161	0.355	4
	20 A	SB203 M-D20	1SYS273012R0201	0.355	4
	25 A	SB203 M-D25	1SYS273012R0251	0.355	4
	32 A	SB203 M-D32	1SYS273012R0321	0.355	4
	40 A	SB203 M-D40	1SYS273012R0401	0.355	4
	50 A	SB203 M-D50	1SYS273012R0501	0.355	4
	63 A	SB203 M-D63	1SYS273012R0631	0.355	4

#### SB204 M D

Number of poles	Rated current	Order details		Weight 1 piece	Pack unit
		In A	Type code		
4P	0.5 A	SB204 M-D0.5	1SYS274012R0981	0.465	3
	1 A	SB204 M-D1	1SYS274012R0011	0.465	3
	1.6 A	SB204 M-D1.6	1SYS274012R0971	0.465	3
	2 A	SB204 M-D2	1SYS274012R0021	0.465	3
	3 A	SB204 M-D3	1SYS274012R0031	0.465	3
	4 A	SB204 M-D4	1SYS274012R0041	0.465	3
	6 A	SB204 M-D6	1SYS274012R0061	0.465	3
	10 A	SB204 M-D10	1SYS274012R0101	0.465	3
	16 A	SB204 M-D16	1SYS274012R0161	0.465	3
	20 A	SB204 M-D20	1SYS274012R0201	0.465	3
	25 A	SB204 M-D25	1SYS274012R0251	0.465	3
	32 A	SB204 M-D32	1SYS274012R0321	0.465	3
	40 A	SB204 M-D40	1SYS274012R0401	0.465	3
	50 A	SB204 M-D50	1SYS274012R0501	0.465	3
	63 A	SB204 M-D63	1SYS274012R0631	0.465	3

# Residual Current Circuit Breaker FB200

A range designed to ensure efficiency and protection.



Bi-directional cylindrical terminal ensures higher safety of connecting operations, making them easier.

Test push-button to verify the correct functioning of the device.

Information on the device is laser printed to make it clearly visible and long lasting.

Laser-marked order code on the front to make easier future orders.



### ISI and CE marking

In addition to international standards and markings IEC, the product is certified as per latest Indian Standards (ISI).



### High performance

- Rated breaking capacity and rated residual breaking capacity laser printed on the device:  
 $I_m = I_{\Delta m} = 1000 \text{ mA}$
- Co-ordination with a 63 A rated current with conditional short-circuit capacity  $I_{nc} = 10000 \text{ A}$ .



### Accessories mountable

Wide a range of add-on accessories having 30 different types of accessories. Max. possibility of mounting: 4 different accessories on the right side and 1 on the left side ensures highest flexibility of functions. Universal contact, motorised unique accessory like mechanical tripping devices available only with ABB.



### Termination

The availability of two terminals offers different connection solutions thanks to the possibility to connect two independent cables in the same device: the second terminal can be used for an auxiliary circuit or for the supply of devices with small section cables without connecting them together with the main circuit.



### Auto reclosing

The FB200 can be coupled with the auto reclosing unit F2C-ARH in order to ensure continuity of service for the whole installation of your home, avoiding lack of supply.



### Dual termination

Two terminals are available, the fore one for cables up to 25 mm<sup>2</sup>, the back one for cables up to 10 mm<sup>2</sup> or for busbars.

## RCCB FB200

### Technical data



<b>General data</b>	
Standards	IEC 61008; IS 12640-1: 2008
Poles	2 P, 4 P
Rated current I <sub>n</sub>	25 A, 40 A, 63 A
Rated residual operating current I <sub>Δn</sub>	30 mA, 100 mA, 300 mA
Type (wave form of the earth leakage sensed)	AC
Rated voltage U <sub>e</sub>	240 / 415 V AC
Rated insulation voltage U <sub>i</sub> acc. to IEC/EN 60664-1	500 V AC
Max. operating voltage of circuit test	254 V AC
Min. operating voltage of circuit test	110 V AC
Rated frequency	50 Hz
Rated conditional short-circuit current I <sub>nc</sub> =I <sub>Δc</sub>	10 kA (with a SCPD)
Rated residual breaking capacity I <sub>Δm</sub> =I <sub>m</sub>	1 kA
Rated impulse withstand voltage (1.2/50) U <sub>imp</sub>	4 kV
Dielectric test voltage	2,5 kV
Surge current resistance (wave 8/20)	250 A
Electrical endurance	10.000 ops.
<b>Mechanical Data</b>	
Toggle	Black, sealable in ON-OFF position
Contact position indication	White Marking on toggle ( I ON / O OFF )
Protection degree acc. to EN 60529	IP20, IP40 in enclosure with cover
Mechanical endurance	20.000 ops.
Environmental conditions (damp heat) acc. to IEC/EN 60068-2-30	Humid heat: 28 cycles with 55°C/95...100%; constant climate conditions: 23°C/83% - 40°C/93% - 55°C/20%; variable climate conditions: 25°C/95% - 40°C/95%
Ambient temperature	-5...+40°C
Storage temperature	-40...+70°C
<b>Installation</b>	
Terminal	Failsafe bi-directional cylinder-lift terminal at top and bottom (shock protected)
Cross-section of conductors (top / bottom)	Solid, Stranded 25 mm <sup>2</sup> / 25 mm <sup>2</sup>
Cross-section of busbars (top / bottom)	10 mm <sup>2</sup> / 10 mm <sup>2</sup>
Tightening Torque	2,8 Nm
Screwdriver	No. 2 Pozidrive
Mounting	On DIN rail 35 mm acc. to EN 60715 by fast clip
Mounting position	Any
Supply	Optional

---

**Dimensions and weight**

---

Pole dimensions (H x D x W)	2P: 85 x 69 x 35 mm; 4P: 85 x 69 x 70 mm
Pole weight	2P: 200 g; 4P: 350 g

---

**Combination with aux. elements**

---

Auxiliary contact	yes
Signal contact	yes
Shunt trip	yes
Undervoltage release	yes
Overvoltage release	yes
Padlock enabled	yes
Auto reclosing unit	yes
Motor operating device	yes

---

**Approvals**

---

ISI approved	yes
--------------	-----

---

## RCCB FB200

AC  type



FB202 AC

**FB200 AC type** Function: protection against the effects of sinusoidal alternating earth fault currents; protection against indirect contacts and additional protection against direct contacts (with  $I_{\Delta n}=30$  mA).

**Application: residential, commercial, industrial**

**Standard: IEC/EN 61008-1; IEC/EN 61008-2-1**

**Marking: according to EN 61008-1; EN 61008-2-1**

### FB202 AC

Number of poles	Rated current	Order details		Weight 1 piece	Pack unit	
		In A	Type code			Order code
2P	25A	25	FB202 AC-25/0.03	1SYF202015R1250	0.215	1
	25A	25	FB202 AC-25/0.1	1SYF202015R2250	0.215	1
	25A	25	FB202 AC-25/0.3	1SYF202015R3250	0.215	1
	40A	40	FB202 AC-40/0.03	1SYF202015R1400	0.215	1
	40A	40	FB202 AC-40/0.1	1SYF202015R2400	0.215	1
	40A	40	FB202 AC-40/0.3	1SYF202015R3400	0.215	1
	63A	63	FB202 AC-63/0.03	1SYF202015R1630	0.215	1
	63A	63	FB202 AC-63/0.1	1SYF202015R2630	0.215	1
	63A	63	FB202 AC-63/0.3	1SYF202015R3630	0.215	1



FB204 AC

### FB204 AC

Number of poles	Rated current	Order details		Weight 1 piece	Pack unit	
		In A	Type code			Order code
4P	25A	25	FB204 AC-25/0.03	1SYF204015R1250	0.395	1
	25A	25	FB204 AC-25/0.1	1SYF204015R2250	0.395	1
	25A	25	FB204 AC-25/0.3	1SYF204015R3250	0.395	1
	40A	40	FB204 AC-40/0.03	1SYF204015R1400	0.395	1
	40A	40	FB204 AC-40/0.1	1SYF204015R2400	0.395	1
	40A	40	FB204 AC-40/0.3	1SYF204015R3400	0.395	1
	63A	63	FB204 AC-63/0.03	1SYF204015R1630	0.395	1
	63A	63	FB204 AC-63/0.1	1SYF204015R2630	0.395	1
	63A	63	FB204 AC-63/0.3	1SYF204015R3630	0.395	1



# Residual Current Circuit Breaker with overcurrent protection DS201 M

A range designed to ensure efficiency and protection.



Bi-directional cylindrical terminal ensures higher safety of connecting operations, making them easier.

Information on the device are laser printed to ensure readability over time.

Each RCBO of the DS201 M range is equipped with an Rfid tag containing a unique serial number assigned to ABB according to the standard ISO/IEC FCD 15693-3 in order to authenticate the product.

The label carrier to clearly identify the protected circuit.

Test pushbutton to verify the correct functioning of the device



Any earth fault can be immediately identified through the blue indicator, that signals the differential tripping and which cannot be activated in case of manual operation on the toggle. This prevents any misinterpretations of the device and system status.



Contact Position Indicator (CPI): to always know the status of the contacts (red: closed contacts; green: open contacts).



The terminals available on DS201 M make easier the supply operation in parallel with busbars as they are composed by two different seats, a front seat for 25 mm<sup>2</sup> cables and a back seat for 10 mm<sup>2</sup> busbars.



All the devices of the DS201 M series have been tested in a wide range of temperatures: from -25°C (as indicated by the snowflake marked on the front side) up to +55°C.

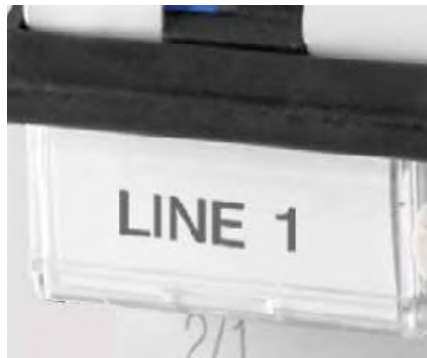

Label carrier for clear and reliable identification. With the practical label carrier fitted in the circuit breakers, you can give maximum visibility to the information relating to the protected loads.



All the quality ensured by the main international marks is clearly visible on the device even if installed in the switchboard.



Product description and EAN code laser printed on the lateral side of the device for easier stock management.

## RCBO DS201 M

### Technical data



		DS201 M				
Standards		IEC/IS 61009-1; IEC/IS 61009-2-1				
Electrical features	Type (wave form of the earth leakage sensed)			AC	APR	
	Poles					
	Rated current $I_n$	A		$4 \leq I_n \leq 40$		
	Rated sensitivity $I_{\Delta n}$	A		0.03-0.1-0.3	0.03-0.1-0.3	
	Rated voltage $U_e$	V	230-240			
	Insulation voltage $U_i$	V	500			
	Operating voltage of circuit test $U_t$	V	110 (170 for 30 mA) - 254			
	Rated frequency	Hz	50...60			
	Rated breaking capacity acc. to IEC/IS 61009	ultimate $I_{cn}$	A	10000		
	Rated breaking capacity acc. to IEC/IS 60947-2	ultimate $I_{cu}$	kA	10		
	1P+N @230 VAC	service $I_{cs}$	kA	7.5		
	Rated residual breaking capacity $I_{\Delta m}$		kA	6		
	Rated impulse withstand voltage (1.2/50) $U_{imp}$		kV			
	Dielectric test voltage at ind. freq. for 1 min.		kV			
	Thermomagnetic release characteristic	B: $3 I_n \leq I_m \leq 5 I_n$		■		
C: $5 I_n \leq I_m \leq 10 I_n$			■	■		
K: $10 I_n \leq I_m \leq 14 I_n$			NA for A, AC versions; 3000 for APR version			
Surge current resistance (wave 8/20)		A	black sealable in ON-OFF position			
Mechanical features	Toggle		differential trip indicator (blue)			
	Flag indicators		contact position indicator (green/red)			
	Electrical life		10000			
	Mechanical life		20000			
	Protection degree	housing		IP4X		
		terminals		IP2X		
	Environmental conditions (damp heat) acc. to IEC/IS 60068-2-30	°C/RH	28 cycles with 55°C/90-96% and 25°C/95-100%			
	Reference temperature for setting of thermal element	°C	30			
	Ambient temperature (with daily average $\leq +35$ °C)	°C	-25...+55			
	Storage temperature	°C	-40...+70			
Installation	Terminal type	top	failsafe bi-directional cylinder-lift terminal at top and bottom (shock protected)			
		bottom	failsafe bi-directional cylinder-lift terminal at top and bottom (shock protected)			
	Terminal size top/bottom for cables	mm <sup>2</sup>	25/25			
	Terminal size top/bottom for busbar	mm <sup>2</sup>	10/10			
	Tightening torque top/bottom	Nm	2.8			
	Mounting		on DIN rail EN 60715 (35 mm) by means of fast clip device			
	Mounting position		Any			
	Connection		from top and bottom			
Dimensions and weight	Dimensions (H x D x W)	mm	85 x 69 x 35			
	Weight	g	239			
Combination with auxiliary elements	Combinable with:	auxiliary contact	yes			
		signal contact	yes			
		shunt trip	yes			
		undervoltage release	yes			

**RCBO DS201 M**10000 AC  type, C characteristic**DS201 M AC type, C characteristic**

Function: protection of end user single-phase circuits against overload and short-circuit currents; protection against the effects of sinusoidal alternating earth fault currents; protection against indirect contact and additional protection against direct contact ( $I_{\Delta n}=30$  mA).

**Application: residential, commercial, industrial.**

**Standard: IEC/EN 61009-1; IEC/EN 61009-2-1**

**$I_{cn} = 10\ 000$  A**



DS201 M AC

Number of poles	Rated residual current $I_{\Delta n}$ mA	Rated current $I_n$ A	Bbn 8012542  EAN	Order details		Weight 1 piece kg.	Pack unit pc.	
				Type code	Order code			
1+N	30	6	999706	DS201 M C6 AC30	2CSR275040R1064	0.240	5	
		10	999805	DS201 M C10 AC30	2CSR275040R1104	0.240	5	
		16	105657	DS201 M C16 AC30	2CSR275040R1164	0.240	5	
		20	105756	DS201 M C20 AC30	2CSR275040R1204	0.240	5	
		25	105855	DS201 M C25 AC30	2CSR275040R1254	0.240	5	
		32	105954	DS201 M C32 AC30	2CSR275040R1324	0.240	5	
	100	100	40	106050	DS201 M C40 AC30	2CSR275040R1404	0.240	5
			6	106951	DS201 M C6 AC100	2CSR275040R2064	0.240	5
			10	107057	DS201 M C10 AC100	2CSR275040R2104	0.240	5
			16	107255	DS201 M C16 AC100	2CSR275040R2164	0.240	5
			20	107354	DS201 M C20 AC100	2CSR275040R2204	0.240	5
			25	107453	DS201 M C25 AC100	2CSR275040R2254	0.240	5
300	300	32	107552	DS201 M C32 AC100	2CSR275040R2324	0.240	5	
		40	107651	DS201 M C40 AC100	2CSR275040R2404	0.240	5	
		6	108559	DS201 M C6 AC300	2CSR275040R3064	0.240	5	
		10	108658	DS201 M C10 AC300	2CSR275040R3104	0.240	5	
		16	108856	DS201 M C16 AC300	2CSR275040R3164	0.240	5	
		20	108955	DS201 M C20 AC300	2CSR275040R3204	0.240	5	
		25	109051	DS201 M C25 AC300	2CSR275040R3254	0.240	5	
		32	109150	DS201 M C32 AC300	2CSR275040R3324	0.240	5	
		40	109259	DS201 M C40 AC300	2CSR275040R3404	0.240	5	

## RCBO DS201 M

10000  APR type, C characteristic

### DS201 M APR type, C characteristic

Function: protection against the effects of sinusoidal alternating and direct pulsating earth fault currents, providing an optimal compromise between safety and continuity of service, thanks to the resistance of unwanted tripping; protection against indirect contact and additional protection against direct contact ( $I\Delta n=30$  mA); protection and isolation of resistive and inductive loads.

**Application: residential, commercial, industrial**

**Standard: IEC/EN 61009-1; IEC/EN 61009-2-1**

**$I_{cn} = 10\,000$  A**



DS201 M APR

Number of poles	Rated residual current $I\Delta n$ mA	Rated current $I_n$ A	Bbn 8012542	Order details		Weight 1 piece kg.	Pack unit pc.
				EAN	Type code		
30	30	6	114154	DS201 M C6 APR30	2CSR275440R1064	0.240	5
		10	114253	DS201 M C10 APR30	2CSR275440R1104	0.240	5
		16	114451	DS201 M C16 APR30	2CSR275440R1164	0.240	5
		20	114550	DS201 M C20 APR30	2CSR275440R1204	0.240	5
		25	114659	DS201 M C25 APR30	2CSR275440R1254	0.240	5
		32	114758	DS201 M C32 APR30	2CSR275440R1324	0.240	5
		40	114857	DS201 M C40 APR30	2CSR275440R1404	0.240	5
		1+N	100	6	127253	DS201 M C6 APR100	2CSR275440R2064
10	127352			DS201 M C10 APR100	2CSR275440R2104	0.240	5
16	127550			DS201 M C16 APR100	2CSR275440R2164	0.240	5
20	127659			DS201 M C20 APR100	2CSR275440R2204	0.240	5
25	127758			DS201 M C25 APR100	2CSR275440R2254	0.240	5
32	127857			DS201 M C32 APR100	2CSR275440R2324	0.240	5
40	127956			DS201 M C40 APR100	2CSR275440R2404	0.240	5
300	300			6	114956	DS201 M C6 APR300	2CSR275440R3064
		10	115052	DS201 M C10 APR300	2CSR275440R3104	0.240	5
		16	115250	DS201 M C16 APR300	2CSR275440R3164	0.240	5
		20	115359	DS201 M C20 APR300	2CSR275440R3204	0.240	5
		25	115458	DS201 M C25 APR300	2CSR275440R3254	0.240	5
		32	115557	DS201 M C32 APR300	2CSR275440R3324	0.240	5
		40	115656	DS201 M C40 APR300	2CSR275440R3404	0.240	5

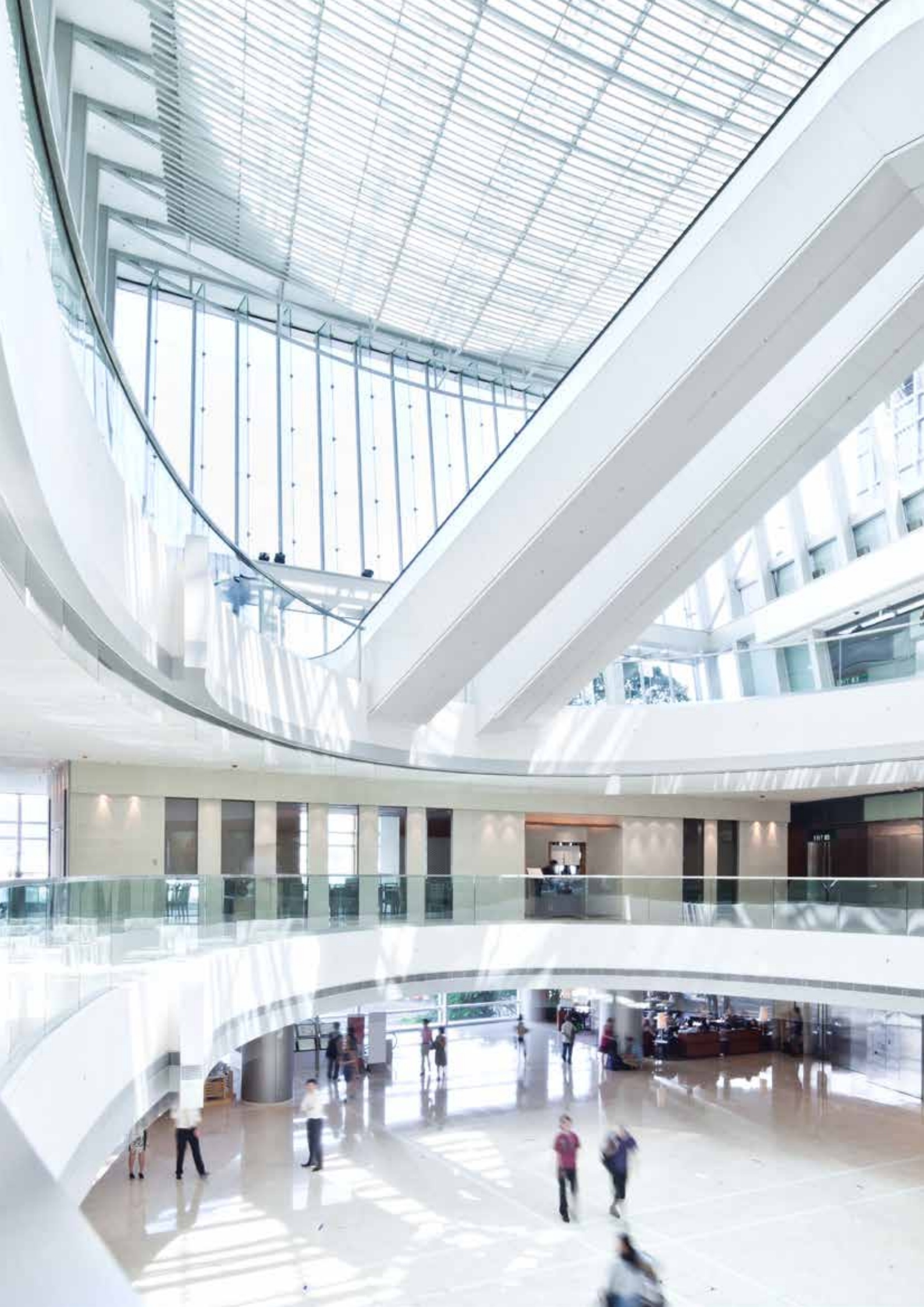

# Switch Disconnecter SDB200

The details make the difference

**Easy product coding – easy identification:** basic technical information already integrated into the name.



IP20 - finger safety.

Fully compatible with all System pro M devices and accessories.

**Patented housing design:** Environment-friendly and performance-optimized.



### Patented Housing Design

By using state-of-the-art housing material, ABB is taking care of the environment. With the latest generation of halogen-free thermoplastics for SDB200, it is possible to recycle the switch disconnectors completely without environmental pollution. The material works for the stability.



### Highest performance

With a rated voltage of 253/440 V AC, a rated conditional short-circuit current of 25 kA, terminals with protection from misconnection, a "Real CPI" switching position display, as well as full compatibility with all MCB accessories, the SDB200 is unique in its field of application. SDB200 complies with IEC/EN 60947-3.



### IP20 protection

IP 20 - finger safe terminals. The System pro M compact® MCBs are equipped with 25 mm<sup>2</sup> cylinder lift twin terminals, a well-proven and reliable technology - designed for sophisticated industrial use. The cross wiring can be easily done by inserting the System pro M compact® busbars into the rear terminal part and then the incoming wires into the front part of the terminal.



### Laser printing

All labels on the SDB200, as the approvals on the dome, technical details and the product identification, are printed by a laser. The laser printing ensures a friction, scratch and solvent resistant marking on the switch disconnectors for easy identification in case of maintenance or replacement. For control and acceptance procedure, it is important to see all markings also in the mounted position.



### ISI and CE marking

In addition to the International standards and markings IEC, the product is certified as per latest Indian Standards (ISI)



### Wide range of accessories

SDB200 is fully compatible to the complete range of System pro M compact accessories like:

- Auxiliary contacts, to be mounted on the left side, the right side or bottom fitting
- Shunt trips
- Undervoltage release
- Motor operating devices

## Switch Disconnecter SDB200

### Technical data



General data	
Standards	IS/IEC 60947-3
Poles	2P, 3P, 4P
Rated current I <sub>n</sub>	40, 63 A
Utilization category	AC-22A, DC-21B
Rated voltage U <sub>e</sub>	2...4P : 415 V AC
Insulation voltage U <sub>i</sub>	250/440 V AC
Max. power frequency recovery voltage (U <sub>max</sub> )	2...4P : 457 V AC; 2P: 120V DC
Min. operating voltage	12 V AC
Rated frequency	50 Hz, DC
Suitable for isolation	yes
Rated conditional short-circuit current	10 kA in series with NH 00 ≤ 63 A gG
Overvoltage category	III
Pollution degree	3
Rated impulse withstand voltage U <sub>imp</sub> . (1.2/50μs)	4 kV (test voltage 6.2kV at sea level, 5kV at 2.000m)
Dielectric test voltage	2 kV (50 / 60Hz, 1 min.)
Overvoltage category	III
Pollution degree	3
Electrical endurance	I <sub>e</sub> < 32 A: 20,000 ops. (AC), I <sub>e</sub> ≥ 32 A: 10,000 ops. (AC), 1,000 ops (DC)
Mechanical data	
Housing	Insulation group II
Toggle	Insulation group II, red, sealable
Contact position indication	White Marking on toggle ( I ON / O OFF )
Protection degree acc. to EN 60529	IP20, IP40 in enclosure with cover
Mechanical endurance	20.000 ops.
Shock resistance acc. to IEC/EN 60068-2-27	25 g - 2 shocks - 13 ms
Vibration resistance acc. to IEC/EN 60068-2-30	5g - 20 cycles at 5...150...5 Hz with load 0.8I <sub>n</sub>
Environmental conditions (damp heat) acc. to IEC/EN 60068-2-30	28 cycles with 55°C/90-96% and 25°C/95-100%
Ambient temperature	-25 ... +55°C
Storage temperature	-40 ... +70°C

<b>Installation</b>	
Terminal	Cage terminal
Cross-section of conductors (top / bottom) Solid, Stranded	25 mm <sup>2</sup> / 25 mm <sup>2</sup>
Flexible	16 mm <sup>2</sup> / 16 mm <sup>2</sup>
Cross-section of busbars (top / bottom)	10 mm <sup>2</sup>
Tightening torque	2 Nm
Screwdriver	No. 2 Pozidrive
Mounting	On DIN rail 35 mm acc. to EN 60715 by fast clip
Mounting position	Any
Supply	Any
<b>Dimensions and weight</b>	
Mounting dimensions acc. to DIN 43880	Mounting dimension 1
Pole dimensions (H x D x W)	85 x 69 x 17.5 mm
Pole weight	ca. 115 g
<b>Combination with aux. elements</b>	
Auxiliary contact	yes
Signal contact	yes
Shunt trip	yes
Undervoltage release	yes
Overvoltage release	yes
Rotary handle	yes
Mechanical tripping device	yes
Padlock enabled	yes
Motor operating device	yes
<b>Approvals</b>	
ISI approved	yes

## Switch Disconnecter SDB200

### Ordering data



SDB203 16A

#### SDB200

Switch disconnecter acc. to IEC/EN 60947-3 for panel installation onto DIN rail (35 mm)

**Mounting depth: 69 mm**

**Mounting width: per pole = 17.5 mm = 1 module**

#### SDB202

Number of poles	Rated current	Order details		Weight 1 piece	Pack unit
		In A	Type code		
2P	40	SDB202/40	1SYD272115R0040	0.145	6
	63	SDB202/63	1SYD272115R0063	0.145	6

#### SDB203

Number of poles	Rated current	Order details		Weight 1 piece	Pack unit
		In A	Type code		
3P	40	SDB203/40	1SYD273115R0040	0.225	4
	63	SDB203/63	1SYD273115R0063	0.225	4

#### SDB204

Number of poles	Rated current	Order details		Weight 1 piece	Pack unit
		In A	Type code		
4P	40	SDB204/40	1SYD274115R0040	0.305	3
	63	SDB204/63	1SYD274115R0063	0.305	3



---

# Miniature Circuit Breaker SB200 DC

## Right product for right application

The range impresses with its performance, approvals and high in-built short-circuit breaking capacity for DC applications. Can be used in SP version at 250V DC and DP version upto 500V DC.

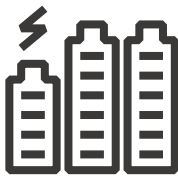
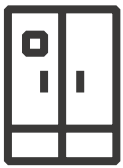

Polarity marking.



IP20 - finger safety.

Captive screws.  
Don't lose what's important for you.



Whatever your application need is – applicable with a wide range of accessories.



Approvals and standard.



**State-of-the-art design  
(Aesthetics & ergonomics)**

Elegant in appearance and the knob is designed for easy operation.



**Laser marking**

All printing of the SB200 MCBs, like the approvals on the product identification are printed by a laser. The laser printing ensures a friction, scratch and solvent resistant marking on the MCBs. Easy identification of the products in case of maintenance or replacement, due to safe laser printing.



**Housing cover with fire retardant material**

High performance 100% recyclable plastic material with fire retardant, high melting point, low water absorption & high dielectric strength properties. ABB is taking care of the environment... with the latest generation of thermoplastics, it is possible to recycle the MCBs – especially the thermoplastic housing material can be re-used. SB200 is 100% free of halogens.

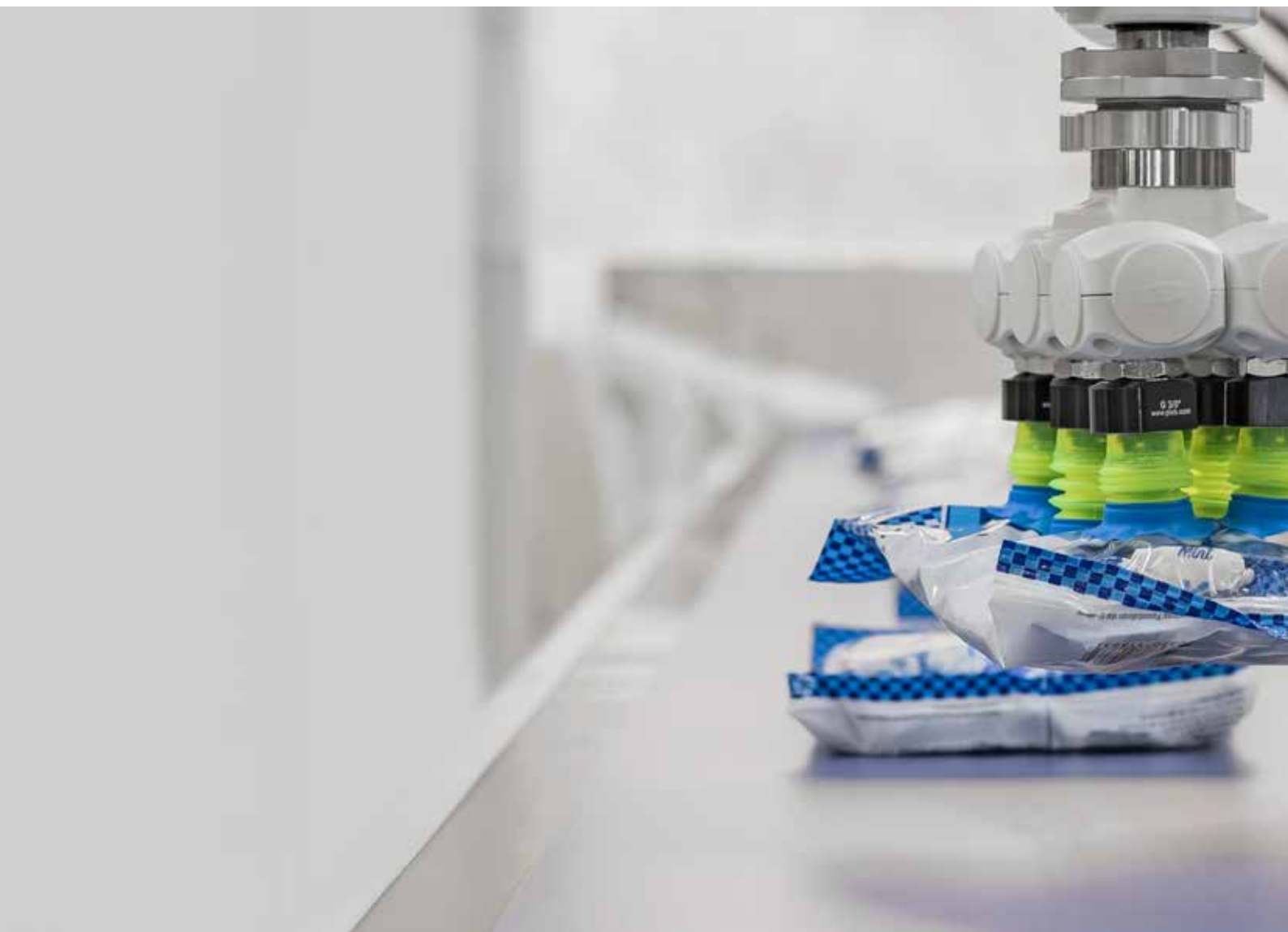



#### IP20 protection

IP 20 - finger safe terminals.  
The System pro M compact® MCBs are equipped with 25 mm<sup>2</sup> cylinder lift twin terminals, a well-proven and reliable technology - designed for sophisticated industrial use.  
The cross wiring can be easily done by inserting the System pro M compact® busbars into the rear terminal part and then the incoming wires into the front part of the terminal.



#### Labelling area

Provision for providing label enables easy identification and polarity marking of circuit during installation, operation & maintenance.



#### Accessories mountable

Wide range of add-on accessories having 30 different types of accessories. Max. possibility of mounting: 4 different accessories on the right side and 1 on the left side ensures highest flexibility of functions. Universal contact, motorised unique accessory like mechanical tripping devices available only with ABB.



## Miniature Circuit Breaker SB200 DC

### Technical data



<b>General data</b>	
Standards	IS/IEC 60947-2
Poles	1P, 2P
Rated short-circuit capacity I <sub>cu</sub>	6 kA
Rated service short-circuit breaking capacity I <sub>cs</sub>	6 kA
Tripping characteristics	7-15 x I <sub>n</sub>
Reference temperature for tripping characteristics	55°C
Rated voltage U <sub>e</sub>	1P: 250 V DC 2P: 500 V DC
Rated current I <sub>n</sub>	1,6, 2, 3, 4, 6, 10, 16, 20, 25, 32, 40, 50, 63 A
Max. power frequency recovery voltage (U <sub>max</sub> )	1,1 x U <sub>e</sub>
Min. operating voltage	12 V DC
Rated impulse withstand voltage U <sub>imp</sub> . (1.2/50μs)	4 kV (test voltage 6.2kV at sea level, 5kV at 2.000m)
Dielectric test voltage	2 kV (50 / 60Hz, 1 min.)
Pollution degree	2
Electrical endurance	1.000 ops.
<b>Mechanical data</b>	
Housing	Insulation group I
Toggle	black sealable in ON-OFF position
Contact position indication	White Marking on toggle ( I ON / O OFF )
Protection degree acc. to EN 60529	IP20, IP40 in enclosure with cover
Mechanical endurance	20.000 ops.
Shock resistance acc. to IEC/EN 60068-2-27	25 g - 2 shocks - 13 ms
Vibration resistance acc. to IEC/EN 60068-2-6	5g - 20 cycles at 5...150...5 Hz with load 0.8I <sub>n</sub>
Environmental conditions (damp heat) acc. to IEC/EN 60068-2-30	28 cycles with 55°C/90-96% and 25°C/95-100%
Ambient temperature	-25 ... +55°C
Storage temperature	-40 ... +70°C
<b>Installation</b>	
Terminal	Cage terminal
Cross-section of conductors (top / bottom) Solid, Stranded	25 mm <sup>2</sup> / 25 mm <sup>2</sup>
Flexible	16 mm <sup>2</sup> / 16 mm <sup>2</sup>
Cross-section of busbars (top / bottom)	10 mm <sup>2</sup>
Tightening torque	2 Nm
Screwdriver	No. 2 Pozidrive
Mounting	On DIN rail 35 mm acc. to EN 60715 by fast clip
Mounting position	Any
Supply	Note polarity of device

---

**Dimensions and weight**

---

Mounting dimensions acc. to DIN 43880	Mounting dimension 1
Pole dimensions (H x D x W)	85 x 69 x 17.5 mm
Pole weight	ca. 115 g

---

**Combination with aux. elements**

---

Auxiliary contact	yes
Signal contact	yes
Shunt trip	yes
Undervoltage release	yes
Overvoltage release	yes
Rotary handle	yes
Mechanical tripping device	yes
Padlock enabled	yes
Motor operating device	yes

---

## MCB SB200 DC C characteristic

### Ordering data



SB201 C 6 DC

#### SB200 DC characteristic

Function: protection and control of the circuits against overloads and short-circuits; protection for resistive and inductive loads with low inrush current.

Applications: residential, commercial and industrial

Standard: IS/IEC 60947-2

Icn=6 kA

#### SB201 DC C

Number of poles	Rated current In A	Order details		Weight 1 piece kg.	Pack unit pc.
		Type code	Order code		
1P	1.6	SB201-C1.6DC	1SYS251067R0974	0.125	12
	2	SB201-C2DC	1SYS251067R0024	0.125	12
	3	SB201-C3DC	1SYS251067R0034	0.125	12
	4	SB201-C4DC	1SYS251067R0044	0.125	12
	6	SB201-C6DC	1SYS251067R0064	0.125	12
	10	SB201-C10DC	1SYS251067R0104	0.125	12
	16	SB201-C16DC	1SYS251067R0164	0.125	12
	20	SB201-C20DC	1SYS251067R0204	0.125	12
	25	SB201-C25DC	1SYS251067R0254	0.125	12
	32	SB201-C32DC	1SYS251067R0324	0.125	12
	40	SB201-C40DC	1SYS251067R0404	0.125	12
	50	SB201-C50DC	1SYS251067R0504	0.125	12
	63	SB201-C63DC	1SYS251067R0634	0.125	12



SB202 C 10 DC

#### SB202 DC

Number of poles	Rated current In A	Order details		Weight 1 piece kg.	Pack unit pc.
		Type code	Order code		
2P	1.6	SB202-C1.6DC	1SYS252067R0974	0.255	6
	2	SB202-C2DC	1SYS252067R0024	0.255	6
	3	SB202-C3DC	1SYS252067R0034	0.255	6
	4	SB202-C4DC	1SYS252067R0044	0.255	6
	6	SB202-C6DC	1SYS252067R0064	0.255	6
	10	SB202-C10DC	1SYS252067R0104	0.255	6
	16	SB202-C16DC	1SYS252067R0164	0.255	6
	20	SB202-C20DC	1SYS252067R0204	0.255	6
	25	SB202-C25DC	1SYS252067R0254	0.255	6
	32	SB202-C32DC	1SYS252067R0324	0.255	6
	40	SB202-C40DC	1SYS252067R0404	0.255	6
	50	SB202-C50DC	1SYS252067R0504	0.255	6
	63	SB202-C63DC	1SYS252067R0634	0.255	6

---

# Accessories

## System pro *M*

- 
- Portfolio overview
  - Technical data
  - Ordering data

# System pro M Accessories



Thanks to the variety of control and monitoring accessories which enable you to build different monitoring control logics of the protection devices.



— S2C-H6...  
Auxiliary contact



— S2C-S/H6R  
Signal/auxiliary contacts



— S2C-A  
Shunt trip



— S2C-UA  
Under voltage release



— S2C-OVP  
Over voltage release



— S2C-CM4  
Motor operating device



— S2C-BP  
Mechanical tripping device

# System pro M

## Accessories for SB200 M/SB200 DC/SDB200

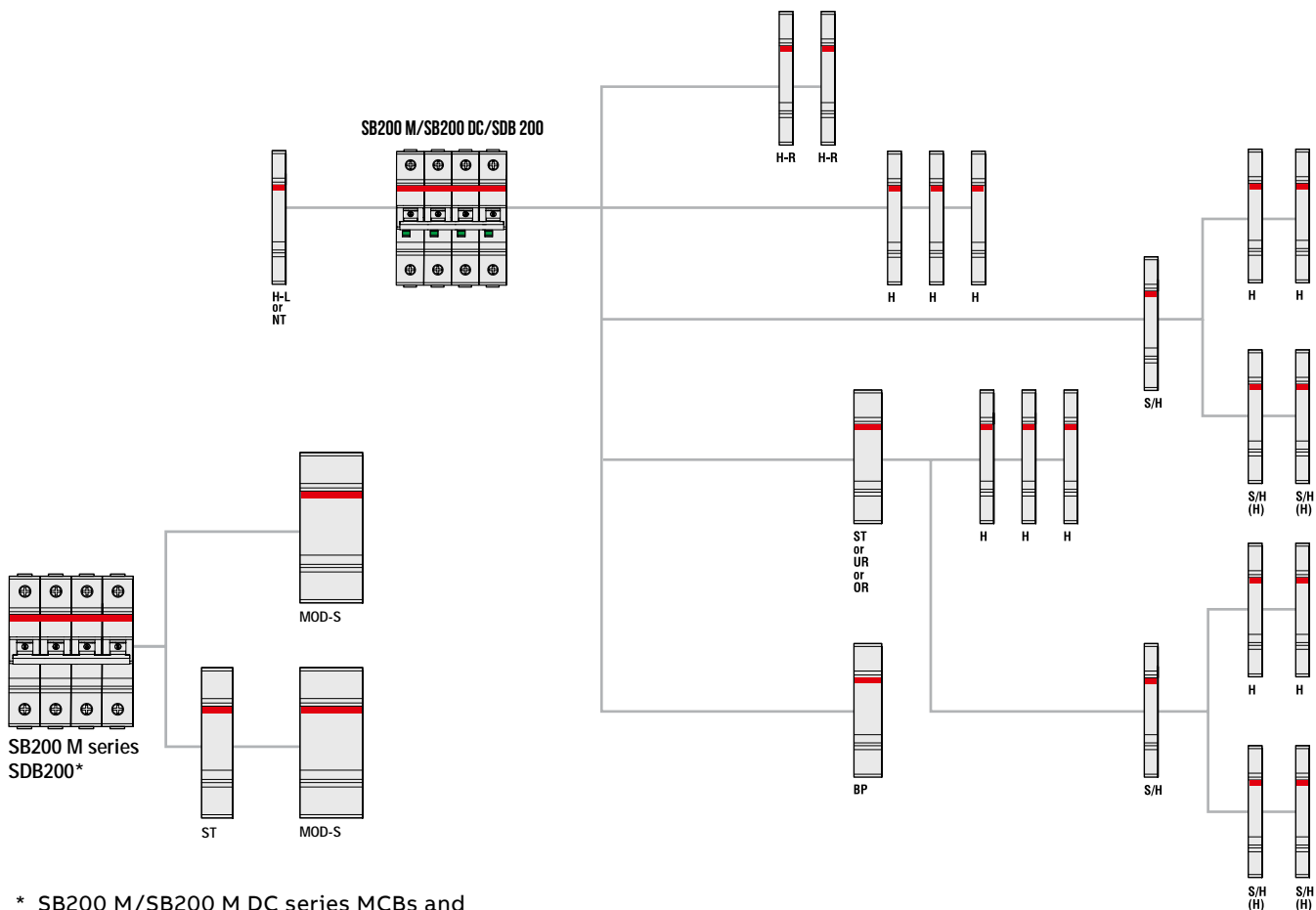

\* SB200 M/SB200 M DC series MCBs and SDB200 switch disconnectors up to 3P or 2P+ST can be coupled with MOD-S

H	Auxiliary contact	S2C-H6R
H-R	Auxiliary contact	S2C-H6...R
S/H	Signal/Auxiliary contact	S2C-S/H6R
S/H (H)	Signal/Auxiliary contact used as auxiliary contact	S2C-S/H6R
ST	Shunt trip for SB200 MCB	S2C-A...
UR	Undervoltage release	S2C-UA
OR	Overvoltage release	S2C-OVP
ST-L	Shunt trip for SB200 MCBs to be mounted on the left	S2C-A...L
H-L	Auxiliary contact for SB200 MCBs to be mounted on the left	S2C-H...L
BP	Mechanical tripping device	S2C-BP
NT	Switched neutral	S2C-Nt

# System pro M

## Accessories for FB200

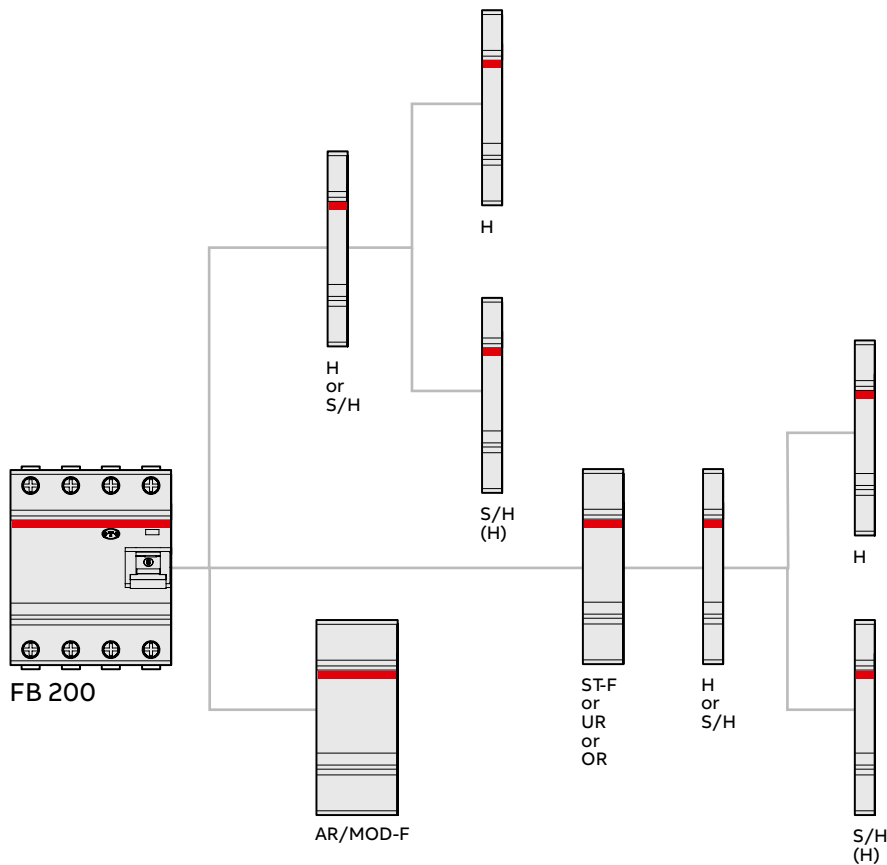

H	Auxiliary contact	S2C-H6R
S/H	Signal/Auxiliary contact	S2C-S/H6R
S/H (H)	Signal/Auxiliary contact used as auxiliary contact	S2C-S/H6R
UR	Undervoltage release	S2C-UA
OR	Overvoltage release	S2C-OVP
AR	Auto reclosing unit	F2C-ARI
MOD-F	Motor operating device	F2C-CM
ST-F	Shunt trip for FB200 RCCB	F2C-A

# System pro M

## Accessories for DS201 M

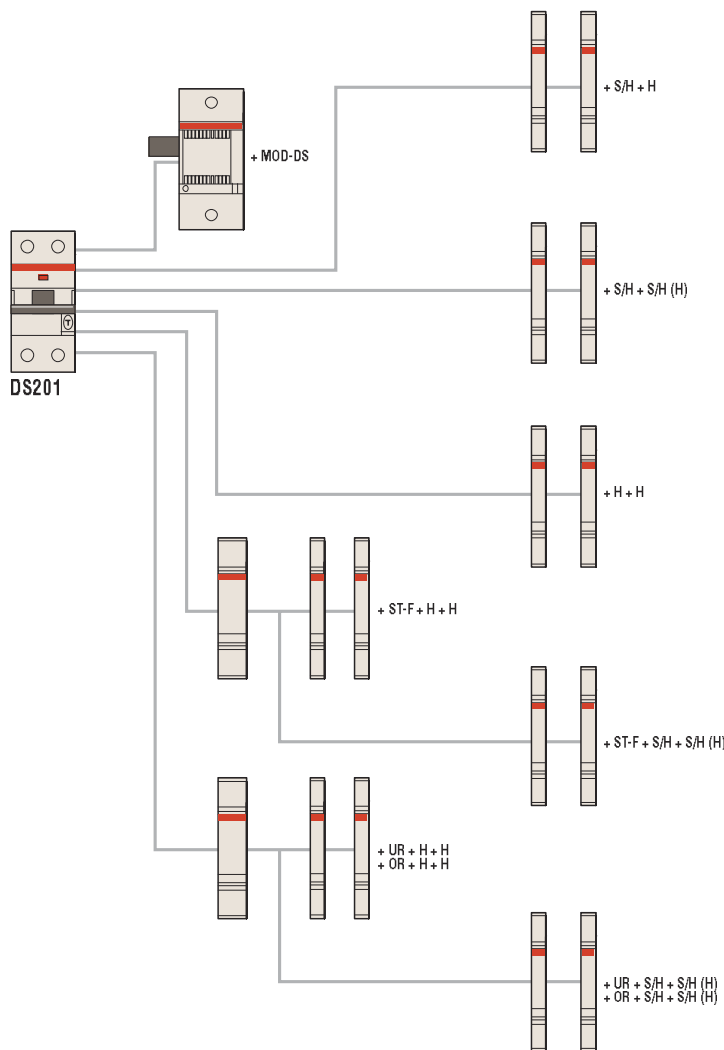

H	Auxiliary contact	S2C-H6R
S/H	Signal/Auxiliary contact	S2C-S/H6R
S/H (H)	Signal/Auxiliary contact used as auxiliary contact	S2C-S/H6R
ST-F	Shunt trip for DS201 RCCB	F2C-A
UR	Undervoltage release	S2C-UA
OR	Oversvoltage release	S2C-OVP
MOD-DS	Motor operating device	DS2C-CM

## Auxiliary elements for

MCBs SB200 M, SB200 M DC, switch disconnecter SDB200 and RCBO DS201 M



Auxiliary elements

Auxiliary contact and signal/auxiliary contact		
S2C-S/H6R, S2C-H6R, S2C-H11L, S2C-H20L and S2C-H02L		
Utilization category		AC14 1A/400V, 2A/230V - DC12 1A/220V, 1,5A/110V - DC13 2A/60V, 4A/24V
Conventional free air thermal current	A	10
Min. operational current/voltage*		10 mA at 12 V; 5 mA at 24 V
Rated conditional short-circuit current	V	230 V AC 1,000 A with S201 K4
Overvoltage category		III
Rated impulse withstand voltage (1.2/50µs)	kV	4
Cross-section of conductors	mm <sup>2</sup>	0.75... 2.5 (up to 2 x 1.5 mm <sup>2</sup> for S2C-H11L, S2C-H20L and S2C-H02L)
Tightening torque	Nm	1.2 (max. 0.8 for S2C-H11L, S2C-H20L and S2C-H02L)
Contact stability in vibration test according to IEC/EN 60 068-2-6		5g, 20 sweep cycles 5...150...5 Hz at 24 V AC/DC, 5 mA automatic reclosing < 10 ms
Mechanical service life		10000 operations
Dimensions (H x D x W)	mm	85 x 69 x 8.8

Auxiliary contact and signal/auxiliary contact		
S2C-H6-11R, S2C-H6-20R, S2C-H6-02R		
Utilization category		AC14: 1A/400V, 2A/230V DC12/DC13: 1A/50V, 2A/30V
Conventional free air thermal current	A	10
Min. rated operational current/voltage*		10 mA at 12 V; 5 mA at 24 V
Rated conditional short-circuit current	V	230 V AC 1,000 A with S201 K4
Overvoltage category		III
Rated impulse withstand voltage (1.2/50µs)	kV	4
Cross-section of conductors	mm <sup>2</sup>	0.75... 2.5
Tightening torque	Nm	1.2
Contact stability in vibration test according to IEC/EN 60068-2-6		5g 20 sweep cycles 5... 150... 5 Hz at 24 V AC/DC. 5mA automatic reclosing < 10 ms
Mechanical service life		10000 operations
Dimensions (H x D x W)	mm	85 x 69 x 8.8

\* ensures safe contacting without current interruption by pollution layer

## Auxiliary elements for

MCBs SB200 M, SB200 DC, switch disconnector SDB200, RCCB-FB200 and RCBO-DS201 M



2C5C400465F0201

S2C-S/H6R

### Signal/auxiliary contacts

Signal contacts indicate if a device tripped due to a failure (overcurrent/short-circuit for MCBs and RCBOs; earth fault for RCCBs and RCBOs). Auxiliary contacts indicate the position of the contacts, independent if a failure occurred or the device was operated manually.

### S2C-S/H6R:

Choice through a selector between signal and auxiliary contact.

### S2C-H6R and S2C-HxxR:

Auxiliary contacts with contact configuration according to the following table. All right-side mounted contacts are suitable for MCBs, RCDs, switch disconnectors SDB200 according to the "Selection tables" which are displayed at the beginning of chapter 4.



2C5C400465F0201

S2C-H6-...

### S2C-HxxL:

Auxiliary contacts with contact configuration according to the following table. These contacts are left-side mounted and fit to SB200 MCBs and switch disconnectors SDB200 according to the "Selection tables". Especially when using a motor operating device this is a possibility to add a contact as the right side mounted ones do not fit within this combination.

### S2C-Hxx:

Unique bottom-fitting contact for the SB200 compact range SDB200 switch disconnectors. Simple and space-saving solution. Also intended for retrofitting.

Description	Bbn 4016779	Order details		Weight 1 piece	Pack unit
	EAN	Type code	Order code	kg	pc.
Signal contact/ auxiliary switch 1CO	563819	S2C-S/H6R	2CDS200922R0001	0.04	1
Auxiliary contact 1CO	563826	S2C-H6R	2CDS200912R0001	0.04	1
Auxiliary contact 1NO/1NC	697941	S2C-H6-11R	2CDS200946R0001	0.04	1
Auxiliary contact 2NO	697958	S2C-H6-20R	2CDS200946R0002	0.04	1
Auxiliary contact 2NC	697965	S2C-H6-02R	2CDS200946R0003	0.04	1

### Auxiliary contacts mounting on the left side

Description	Bbn 4016779	Order details		Weight 1 piece	Pack unit
	EAN	Type code	Order code	kg	pc.
Auxiliary contact 1 NO/1NC	648820	S2C-H11L	2CDS200936R0001	0.04	1
Auxiliary contact 2 NO	648837	S2C-H20L	2CDS200936R0002	0.04	1
Auxiliary contact 2 NC	648844	S2C-H02L	2CDS200936R0003	0.04	1

## Auxiliary elements for

MCBs SB200 M, SB200 M DC, switch disconnecter SDB200 and RCBO DS201 M



Shunt trip for S200 MCBs								
S2C-A1								
Rated voltage	AC	V	12...60					
	DC	V	12...60					
Max. release duration		ms	<10					
Min. release voltage	AC	V	7					
	DC	V	10					
Power consumption	Ub	V	12	12	24	24	60	60
		DC	DC	AC	DC	AC	DC	AC
	Ib max	A	2.2	2.5	4.5	5	14	8.8
Coil resistance		Ω	3.7					
Terminals	Fale-safe bi-directional cylinder-lift-terminal							
Tightening torque		Nm	2.8					
Dimensions (H x D x W)		mm	85 x 69 x 17.5					
S2C-A2								
Rated voltage	AC	V	110...415					
	DC	V	110...250					
Max. release duration		ms	<10					
Min. release voltage	AC	V	55					
	DC	V	80					
Power consumption	Ub	V	110	110	220	230	415	
		DC	DC	AC	DC	AC	AC	
	Ib max	A	0.4	0.5	1.1	1.0	2.7	
Coil resistance		Ω	225					
Terminals	Fale-safe bi-directional cylinder-lift-terminal							
Tightening torque		Nm	2.8					
Dimensions (H x D x W)		mm	85 x 69 x 17.5					

### Shunt trips

Function: remote opening of the device when a voltage is applied. Suitable for MCBs SB200 series, RCBOs DS201 series, SDB200 switch disconnectors series.

Shunt trips use a coil like MCBs for tripping. To trip a shunt it is necessary to choose the right voltage and make sure the corresponding Ibmax (as mentioned in the table above) is provided by the power supply used. If the power supply can provide higher currents the shunt trip will reduce the current to Ibmax due to its internal resistance.

As soon as the shunt tripped, the contact inside is open – the electrical circuit is disconnected even if the shunt trip is still powered on. The free-tripping mechanism of the shunt trip allows a restart of the MCB only after the shunt trip gets no external release signal anymore.

Rated voltage	Bbn 4016779	Order details		Weight 1 piece	Pack unit
		EAN	Type code		
AC/DC 12...60 V	570992	S2C-A1	2CDS200909R0001	0.15	1
AC 110...415 V/DC110...250 V	571005	S2C-A2	2CDS200909R0002	0.15	1

## Auxiliary elements for RCCB FB200



F2C-A

2CSS40013F0202

Shunt trip for RCCB FB200 and RCBO DS201 M							
F2C-A1							
Rated voltage	AC	V	12...60				
	DC	V	12...60				
Max. release duration		ms	10				
Min. release voltage	AC	V	6				
	DC	V	4.5				
Consumption on release	Ub	V	12 DC	12 AC	24 DC	60 DC	60 AC
	Ib max	A	0.88	0.65	1.58	5.8	5
Coil resistance		Ω	5.5				
Terminals		mm <sup>2</sup>	2x1.5				
Tightening torque		Nm	0.2				
Dimensions (H x D x W)		mm	85 x 69 x 17.5				
F2C-A2							
Rated voltage	AC	V	110...415				
	DC	V	110...250				
Max. release duration		ms	10				
Min. release voltage	AC	V	75				
	DC	V	55				
Power consumption	Ub	V	110 DC	110 AC	250 DC	415 AC	
	Ib max	A	0.05	0.03	0.1	0.16	
Coil resistance		Ω	1355				
Terminals		mm <sup>2</sup>	2x1.5				
Tightening torque		Nm	0.2				
Dimensions (H x D x W)		mm	85 x 69 x 17.5				

Function: remote opening of the device when a voltage is applied. Suitable for RCCBs FB200 series and RCBOs DS201.

Rated voltage	Bbn 8012542	Order details		Weight 1 piece	Pack unit
		EAN	Type code		
AC/DC 12...60V	974901	F2C-A1	2CSS200933R0011	0.15	1
AC 110...415V / DC 110...250V	975007	F2C-A2	2CSS200933R0012	0.15	1

## Auxiliary elements for

MCBs SB200 M, SB200 M DC, switch disconnecter SDB200 and RCBO DS201 M



S2C-UA

2CSS400325F0201

Undervoltage release			S2C-UA 12 DC	S2C-UA 24 AC	S2C-UA 24 DC	S2C-UA 48 AC	S2C-UA 48 DC
Standards			IEC/EN 60947-1				
Rated voltage	AC	V	24		48		
	DC	V	12	24		48	
Frequency		Hz	50...60				
Release trip		V	0.35 Un $\geq$ V $\geq$ 0.7 Un				
Terminals		mm <sup>2</sup>	2x1.5				
Consumption		VA	2.2	3.6	2	3.6	2.1
Resistance to corrosion		°C/RH	constant atmosphere: 23/83 - 40/93 - 55/20; variable atmosphere: 25/95 - 40/93				
Protection degree			IPXXB/IP2X				
Tightening torque		Nm	0.4				
Dimensions (H x D x W)		mm	85 x 69 x 17.5				
Undervoltage release			S2C-UA 110 AC	S2C-UA 110 DC	S2C-UA 230 AC	S2C-UA 230 DC	S2C-UA 400 AC
Standards			IEC/EN 60947-1				
Rated voltage	AC	V	110	230		400	
	DC	V	110		230		
Frequency		Hz	50...60				
Release trip		V	0.35 Un M V M 0.7 Un				
Terminals		mm <sup>2</sup>	2x1.5				
Consumption		VA	3.5	2.2	3.7	2.3	2.4
Resistance to corrosion		°C/RH	constant atmosphere: 23/83 - 40/93 - 55/20; variable atmosphere: 25/95 - 40/93				
Protection degree			IPXXB/IP2X				
Tightening torque		Nm	0.4				
Dimensions (H x D x W)		mm	85 x 69 x 17.5				

### Undervoltage releases

Function: protection of the load in the event of a voltage drop (between 70% and 35% of its rated value); positive safety (device's tripping when the voltage is disconnected) emergency stop by means of a button. Suitable for MCBs SB200 series, RCCBs FB200 series and RCBOs DS201, SDB200 switch disconnectors series.

Rated voltage	Bbn 8012542	Order details		Weight 1 piece	Pack unit
		EAN	Type code		
12V DC	839705	S2C-UA 12 DC	2CSS200911R0001	0.09	1
24V AC	839804	S2C-UA 24 AC	2CSS200911R0002	0.09	1
24V DC	896401	S2C-UA 24 DC	2CSS200911R0007	0.09	1
48V AC	839903	S2C-UA 48 AC	2CSS200911R0003	0.09	1
48V DC	896500	S2C-UA 48 DC	2CSS200911R0008	0.09	1
110V AC	840008	S2C-UA 110 AC	2CSS200911R0004	0.09	1
110V DC	896609	S2C-UA 110 DC	2CSS200911R0009	0.09	1
230V AC	840107	S2C-UA 230 AC	2CSS200911R0005	0.09	1
230V DC	896708	S2C-UA 230 DC	2CSS200911R0010	0.09	1
400V AC	840206	S2C-UA 400 AC	2CSS200911R0006	0.09	1

## Auxiliary elements for

MCBs SB200 M, SB200 M DC, switch disconnecter SDB200 and RCBO DS201 M



S2C-OVP

2CSS400677F0001

Overvoltage release			
		S2C - OVP2	S2C - OVP1
Rated voltage	VAC	230	
Rated frequency	Hz	50	
Max. non-tripping voltage AC	V	253	
Max. tripping voltage AC	V	290	275
Tripping time	@ 290V AC	s	t<1
	@ 380V AC	s	t<0.1
Peak current	@ 315V AC	A	1
	@ 440V AC	A	1.8
Max. duration of impulse command	ms	7	
Operating temperature	°C	-5....+40	

### Overvoltage release

Function: monitoring voltage between the neutral and phase; when an overvoltage reaches the threshold value, the OVP device causes the tripping of the associated MCB or RCCB. Suitable for MCBs of the SB200 series up to 63 A, and RCCBs of the FB200 series up to 100 A and RCBOs DS201, Suitable for SDB200 switch disconnectors series.

Description	Bbn 8012542	Order details		Weight 1 piece	Pack unit
		EAN	Type code		
Overvoltage release (max. tripping voltage AC: 275V)	748137	S2C-OVP1	2CSS200910R0005	0.100	1/5
Overvoltage release (max. tripping voltage AC: 290V)	952039	S2C-OVP2	2CSS200993R0005	0.100	1/5



S2C-Nt

2CSC400005F0201

Hand operated neutral left side mounted		
		S2C-Nt
Rated current	A	max. 40
Terminal	mm <sup>2</sup>	10; cage terminal
Tightening torque	Nm	1.2
Dimensions (H x D x W)	mm	85 x 69 x 8.8

### Hand operated neutral

The hand operated neutral has to be mounted to the left side of the MCB and be snapped onto the DIN rail. It is used for measuring duties where the neutral conductor must be in the open position. Due to the special design of the handle - when switching ON the MCB - the neutral will make before the MCB is closed. Suitable for SDB200 switch disconnectors series. The S2C - Nt is not to switch with a tool (screwdriver).

Description	Bbn 4016779	Order details		Weight 1 piece	Pack unit
		EAN	Type code		
Max 40A	647625	S2C-Nt	2CDS200918R0001	0.06	1

## Auxiliary elements for

MCBs SB200 M, SB200 DC, switch disconnecter SDB200, RCCB FB200 and RCBO DS201 M



S2C-CM

ZCS540024BF0201

Motor operating devices			
		S2C-CM	F2C-CM
Supply	V	12 ... 30 V AC +10% - 15% (50-60Hz); 12 ... 48 V DC +10% - 15%	
Power consumption during the operation	12 V AC	VA	< 15
	24 V AC	VA	< 22
	30 V AC	VA	< 25
	12 ... 48 V DC	VA	< 20
Power consumption at rest	VA	< 1.5	
Make-time at ambient temperature	sec	< 1	
Opening time at ambient temperature	sec	< 0.5	
Number of operations		< 20000	
Operating temperature	°C	- 25 ... + 55	
Cables length of control circuit	m	< 1500	
Cables cross-section	mm <sup>2</sup>	< 2.5	
Signal contact (terminals 3 – 4 – 5) Current carrying capacity		1NA + 1NC (change-over contact) 5 A (250 V AC) (inductive-ohmic load)	
Auxiliary contact (terminals 6 – 7 – 8) Current carrying capacity		1NA + 1NC (change-over contact) 3 A (250 V AC) (inductive-ohmic load)	
Remote control*		By means of dry contacts	
Remote control terminals		Terminal 9 = make contact; Terminal 10 = opening contact Terminal 11 = common reference for control contacts, +5V DC (supplied by the motor operating device)	

\* Note: In case of the device opening due to a fault, please wait 8 seconds before attempting to reclose the motor operator.

## Auxiliary elements for

MCBs SB200 M, SB200 DC, switch disconnecter SDB200, RCCB FB200 and RCBO DS201 M

Motor operating devices			
DS2C-CM			
Supply	V	12 ... 30 V AC + 10% - 15% (50-60Hz); 12 ... 48 V DC + 10% - 15%	
Insulation voltage	V	2500 for 1 minute	
Power consumption during the operation	12 V AC	VA	< 15
	24 V AC	VA	< 22
	30 V AC	VA	< 25
	12 ... 48 V DC	VA	< 20
Power consumption at rest	VA	< 1.5	
Remote control*	by means of dry contacts		
Make-time at ambient temperature	sec	< 1	
Opening time at ambient temperature	sec	< 0.5	
Time before attempting to reclose the motor operator	sec	8	
Number of operations	< 20000		
Operating temperature	°C	- 25 ... + 55	
Storage temperature	°C	- 40 ... + 70	
Mounting	on DIN rail EN 60715 by means of fast clip device		
Protection degree (EN 60529)	terminals: IP2X		
	enclosure: IP4X		
Cable length of control circuit	m	< 1500	
Cables cross-section	mm <sup>2</sup>	< 2.5	
Signal contact (terminals 3 – 4 – 5)	1NO + 1NC (change-over contact)		
Current carrying capacity	5 A (250 V AC) (resistive load)		
Auxiliary contact (terminals 6 – 7 – 8)	1NO + 1NC (change-over contact)		
Current carrying capacity	3 A (250 V AC) (resistive load)		
Remote control terminals	Terminal 9 = make contact; Terminal 10 = opening contact Terminal 11 = common reference for control contacts, +5 V DC (supplied by the motor operating device)		

\* Note: In case of the device opening due to a fault, please wait 8 seconds before attempting to reclose the motor operator.

### Motor operating devices

Function: S2C-CM, F2C-CM and DS2C-CM allow the remote control (opening or closing) of the coupled device. Suitable for SB200 series MCBs and SDB200 switch disconnectors, FB200 RCCBs and RCBOs DS201.

Description	Bbn 8012542	Order details		Weight 1 piece	Pack unit
	EAN	Type code	Order code	kg	pc.
Motor operating device for 1P S200 series MCBs and SD200 switch disconnectors	026259	S2C-CM1	2CSS201997R0013	0.166	1
Motor operating device for 2P and 3P S200 series MCBs and SD200 switch disconnectors	026358	S2C-CM2/3	2CSS203997R0013	0.166	1
Motor operating device for 4P S200P MCBs	026457	S2C-CM4	2CSS204997R0013	0.166	1
Motor operating device for 2P and 4P F200 RCCBs	026556	F2C-CM	2CSF200997R0013	0.166	1
Motor operating device for 1P+N and 2P DS201, DS202C RCBOs	135951	DS2C-CM	2CSR201997R0013	0.166	1
Motor operating device for F200 125A RCCB	020721	F2-125A-24V-CM4	2CSF200997R1214	0.36	1
Motor operating device for F200 125A RCCB	600626	F2-125A-230V-CM4	2CSF200997R1205	0.36	1

## Auxiliary elements for RCCB FB200



F2C-ARI

2CSF200995R0013

		Auto-reclosing unit	
		F2C-ARI	F2C-ARI30
Supply	V	12 ... 30 V AC +10% - 15% (50-60Hz); 12 ... 48 V DC +10% - 15%	
Number of automatic reset attempts		3	
Time of reset of the auto-reset meter	sec	12	45
Power consumption during the operation	12 V AC	VA	< 15
	24 V AC	VA	< 22
	30 V AC	VA	< 25
	12 ... 48 V DC	VA	< 20
Power consumption at rest	VA	< 1.5	
Waiting time between auto-reset attempts	sec	3	30
Closing time at ambient temperature	sec	< 1	
Opening time at ambient temperature		< 0.5	
Number of operations		< 20000	
Operating temperature	°C	- 25 ... + 55	
Cable length of control circuit	m	< 1500	
Cables cross-section	mm <sup>2</sup>	< 2.5	
Signaling contact to signal a locked state following three auto-reset attempts (terminals 3–4–5)		1NA + 1NC (change-over contact)	
Current carrying capacity		5 A (250 V AC) (ohmic load)	
Auxiliary contact (terminals 6–7–8)		1NA + 1NC (change-over contact)	
Current carrying capacity		3 A (250 V AC) (ohmic load)	
Remote control		By means of dry contacts	
Remote control terminals		Terminal 9 = closing and remote reset contact for locked state; Terminal 10 = opening contact  Terminal 11 = common reference for control contacts, +5V DC (supplied by the motor operating device)	

### Auto-reclosing units

Function: F2C-ARI and F2C-ARI30 allow the auto-reclosing of the coupled device in case of unwanted tripping. Suitable for FB200 RCCBs up to 100 A.

Description	Bbn	Order details		Weight	Pack
	8012542	Type code	Order code	1 piece	unit
	EAN			kg	pc.
Auto-reclosing unit for 2P and 4P F200 RCCBs	026655	F2C-ARI	2CSF200996R0013	0.166	1
Auto-reclosing unit for 2P and 4P F200 RCCBs (30")	064350	F2C-ARI30	2CSF200995R0013	0.166	1

## Auxiliary elements for RCCB FB200



F2C-ARH

2CSC400678F0001



F2C-ARH-T

2CSC400014F0202

### Home automatic resetting unit

F2C-ARH /F2C-ARH-T		
Power supply	VAC	230
Number of automatic reclosing attempts		1
Reset time for counter of automatic reclosing attempts	sec	12
Power absorbed during the operation	VA	(t<0.5s) 20 max
Power consumption in stand-by	W	0.4 max
Number of operations		≤ 10000
Operating temperature	°C	-25 ... + 55
Signal contact cable section	mm <sup>2</sup>	≤ 2.5
Signal contact for the locked state (terminals 1-2)		1NA (change-over contact)
Signal contact rated current	A	3 (250V AC)

### Home automatic resetting unit (for domestic and similar applications)

Function: it recloses the associated residual current device, only after having checked that there are no effective faults in the system protected by the RCCB.

Suitable for 2-pole RCCB series with 30 mA or 100 mA sensitivities, max 63 A

Description	Bbn	Order details		Weight	Pack
	8012542			1 piece	unit
	EAN	Type code	Order code	kg	pc.
Home automatic resetting unit (30 mA)	732433	F2C-ARH	2CSF200992R0005	0.200	1
Home automatic resetting unit (100 mA)	658535	F2C-ARH100	2CSF200990R0005	0.200	1

### Home automatic resetting unit with autotest (for domestic and similar applications)

Function: it recloses the associated residual current device, only after having checked that there are no effective faults in the system protected by RCCB.

Suitable for 2-pole RCCB series with 30 mA or 100 mA sensitivities, max 63 A.

F2C-ARH-T allows the RCCB automatic test every six months.

Description	Bbn	Order details		Weight	Pack
	8012542			1 piece	unit
	EAN	Type code	Order code	kg	pc.
Home automatic resetting unit (30 mA) with RCCB autotest	733232	F2C-ARH-T	2CSF200991R0005	0.200	1
Home automatic resetting unit (100 mA) with RCCB autotest	593836	F2C-ARH-T100	2CSF200989R0005	0.200	1



---

## Technical details

System pro *M* MCBs and RCBOs.

- 
- Co-ordination tables
  - Tripping characteristics
  - Limitation curves
  - Wiring diagram
  - Overall dimension details



XT3			XT4										
B,C,N,S,H,L,V													
TM													
160	200	250	20	25	32	50	80	100	125	160	200	225	250
T	T	T	6	6	6	7.5	T	T	T	T	T	T	T
T	T	T	3	6	6	7.5	T	T	T	T	T	T	T
T	T	T	3	3	5	6.5	9	T	T	T	T	T	T
T	T	T		3	5	6.5	8	T	T	T	T	T	T
T	T	T		3	5	6.5	8	T	T	T	T	T	T
T	T	T				5	7.5	T	T	T	T	T	T
T	T	T				5	7.5	T	T	T	T	T	T
T	T	T					6	T	T	T	T	T	T
T	T	T					5	T	T	T	T	T	T

XT3			XT4										
B,C,N,S,H,L,V													
TM													
160	200	250	20	25	32	50	80	100	125	160	200	225	250
T	T	T	T	T	T	T	T	T	T	T	T	T	T
T	T	T	T	T	T	T	T	T	T	T	T	T	T
T	T	T	T	T	T	T	T	T	T	T	T	T	T
T	T	T	6.0	6.0	6.0	7.5	T	T	T	T	T	T	T
T	T	T	3.0	6.0	6.0	7.5	T	T	T	T	T	T	T
T	T	T	3.0	3.0	5.0	6.5	9.0	T	T	T	T	T	T
T	T	T		3.0	5.0	6.5	8.0	T	T	T	T	T	T
T	T	T		3.0	5.0	6.5	8.0	T	T	T	T	T	T
T	T	T				5.0	7.5	T	T	T	T	T	T
T	T	T				5.0	7.5	T	T	T	T	T	T
T	T	T					6.0	T	T	T	T	T	T
T	T	T					5.0	T	T	T	T	T	T
T	T	T					5.0	T	T	T	T	T	T
T	T	T						T	T	T	T	T	T

XT3			XT4										
B,C,N,S,H,L,V													
TM													
160	200	250	20	25	32	50	80	100	125	160	200	225	250
T	T	T	6.0	6.0	6.0	7.5	T	T	T	T	T	T	T
T	T	T	3.0	4.5	5.0	7.5	T	T	T	T	T	T	T
T	T	T		3.0	4.5	6.0	9.0	T	T	T	T	T	T
T	T	T				4.5	5.5	T	T	T	T	T	T
T	T	T					5.5	T	T	T	T	T	T
T	T	T					5.0	T	T	T	T	T	T
T	T	T					5.0	T	T	T	T	T	T
T	T	T					5.0	T	T	T	T	T	T
T	T	T					5.0	T	T	T	T	T	T
10.0	T	T					5.0	6.0	T	T	T	T	T
10.0	T	T							T	T	T	T	T







# MCBs technical details

## Tripping characteristics SB200M

**Characteristics B**  
IEC-EN60898

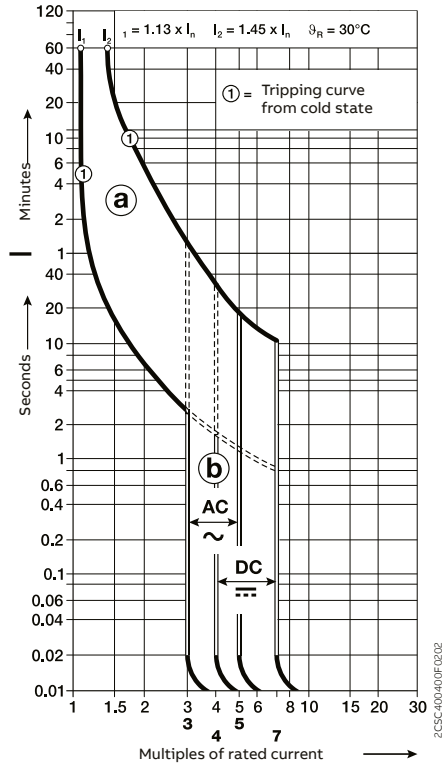

**Characteristics C**  
IEC-EN60898

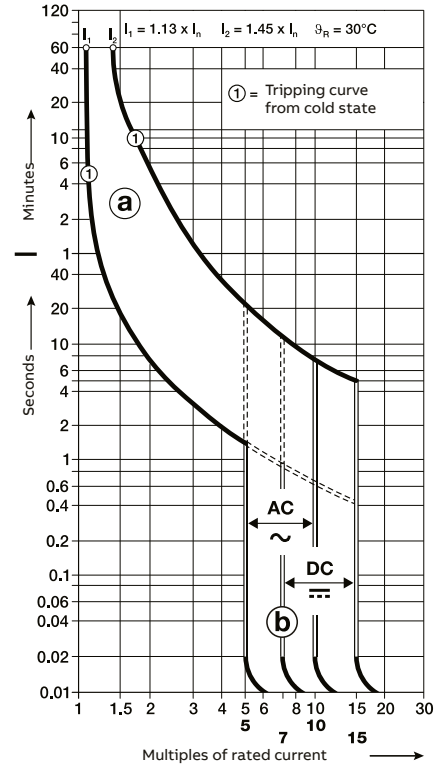

**Characteristics D**  
IEC-EN60898

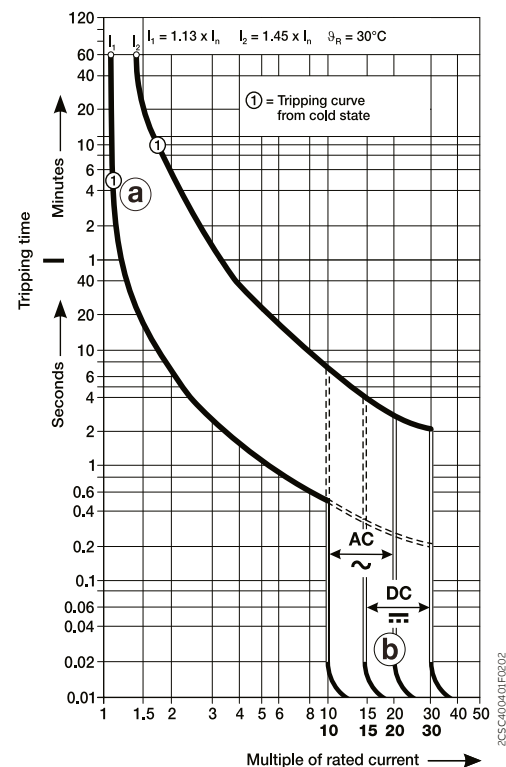

# Wiring diagram

## System Pro M

### MCBs

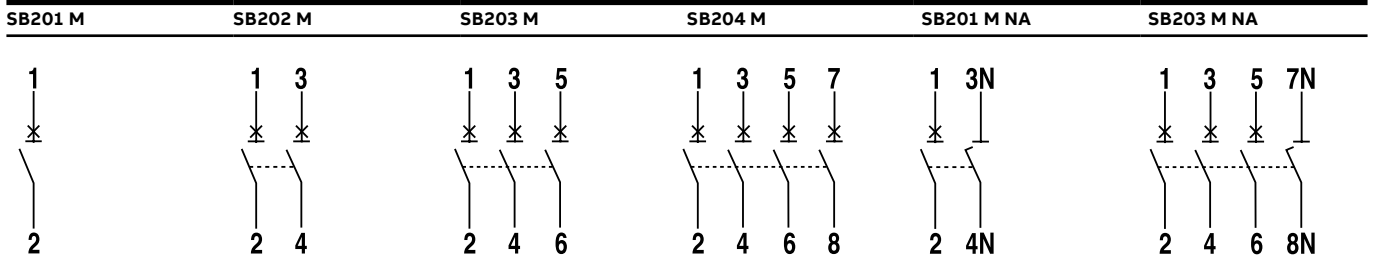

### RCCBs

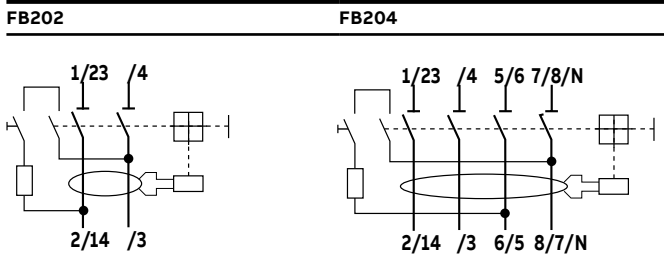

### RCBOs

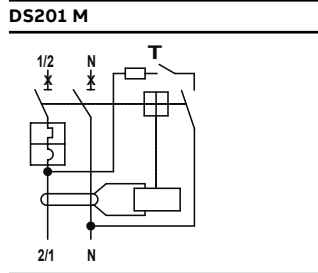

### Switch disconnect

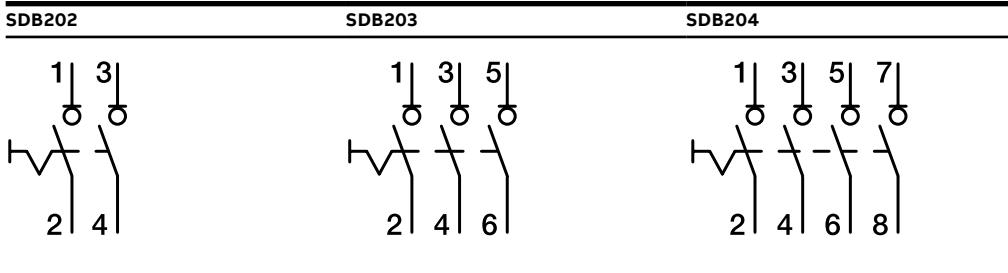

# Wiring diagram

## SB200 DC

**Example for permissible voltages between the conductors, depending on the number of poles and circuit layout:**

voltage between conductors	$U_n$	250 V-	500 V-	500 V-	500 V-
voltage between conductors and earth	$U_n$	250 V-	250 V-	500 V-	250 V-
MCB		1-pole SB200 DC	2-pole SB200 DC	2-pole SB200 DC	2-pole SB200 DC
supply from below					
supply from above					

### Supply and load connections

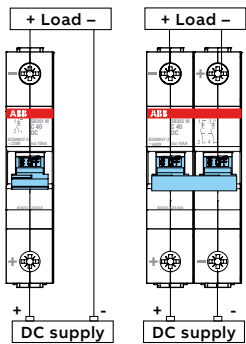

When supply is given at lower terminals

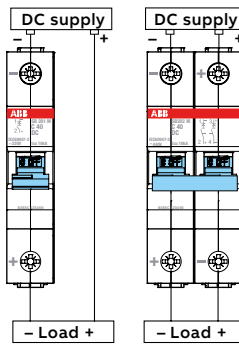

When supply is given at upper terminals

### Auxiliary elements

<b>S2C-S/H6R</b>	<b>S2C-H6R</b>	<b>S2C-H-11R</b>	<b>S2C-H6-20R</b>
Used as signal contact	Used as auxiliary contact	Used as auxiliary contact	Used as auxiliary contact
Automatic opening	Automatic opening	Automatic opening	Automatic opening
Manual opening			

### Auxiliary elements

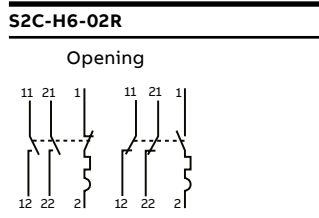

## Overall dimensions

### System Pro M

#### MCB SB200 M and Switch disconnecter SDB200

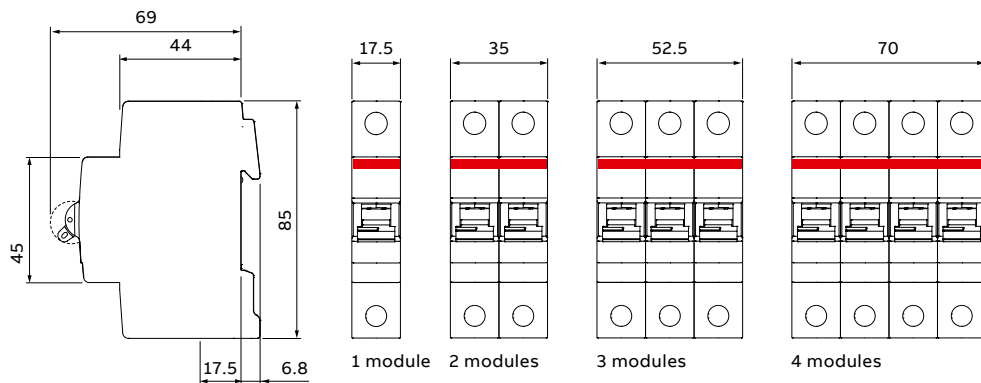

#### MCB SB200 DC

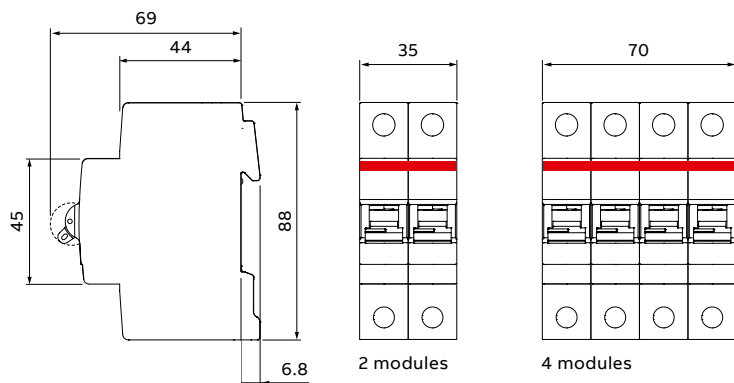

#### RCCB FB200

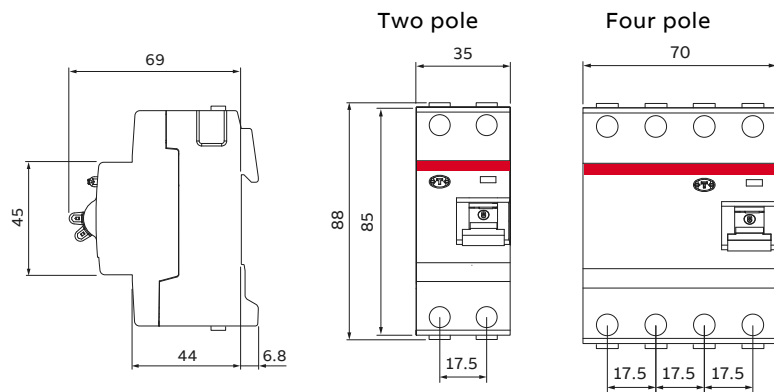

#### RCBO DS201 M

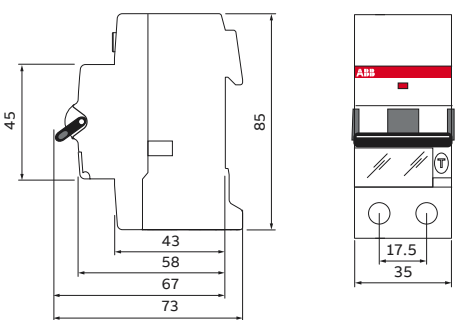

---

# Related offering

## Circuit Monitoring System

- 
- [Overvoltage protection overview](#)
  - [CMS700 overview](#)

# OVR T1-T2, T2 and T2-T3 ranges. The details make the difference

A complete range for your surge protection

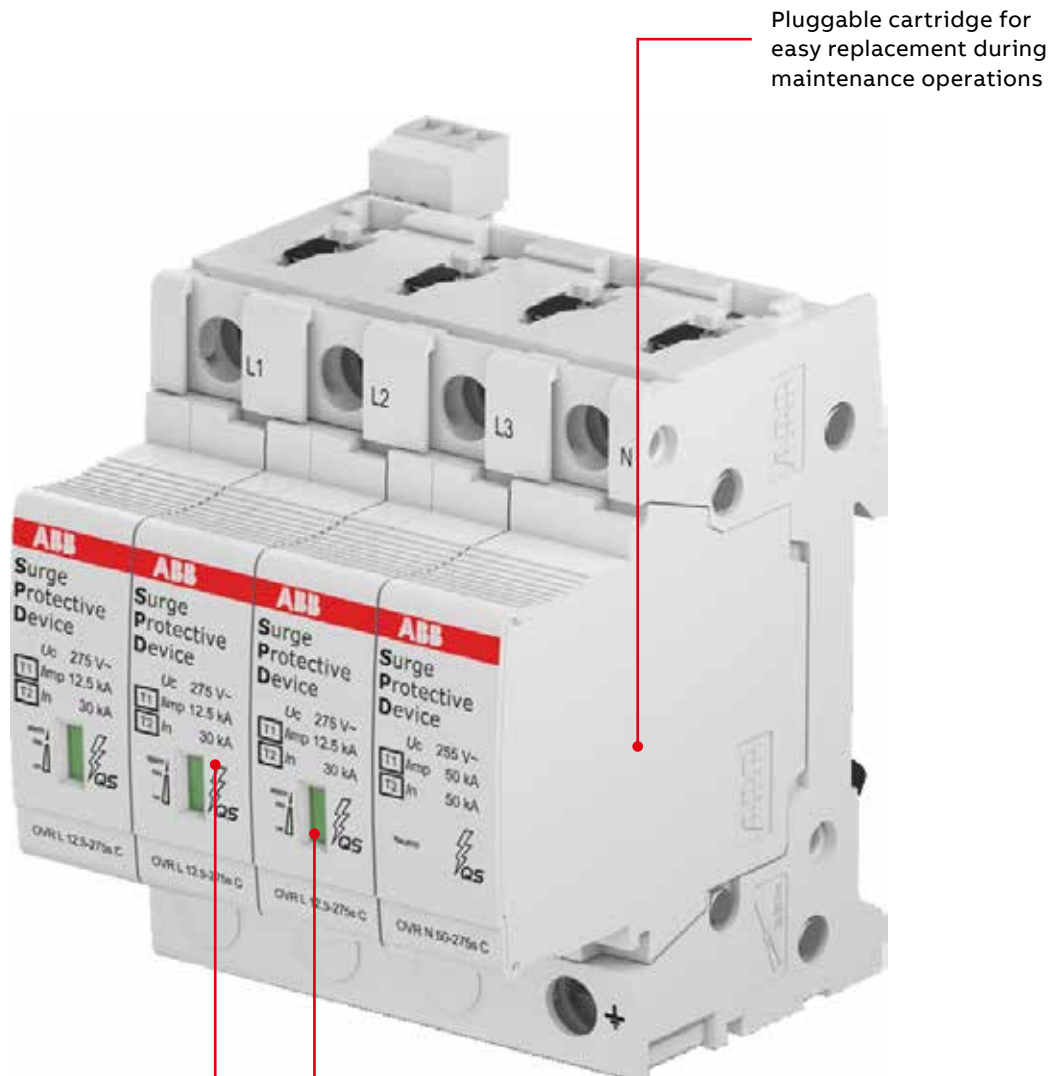

Pluggable cartridge for easy replacement during maintenance operations

Clear information on the front of the product indicating the technical characteristics of the OVR.

Safety Reserve system with two varistors per line to extend protection lifetime.

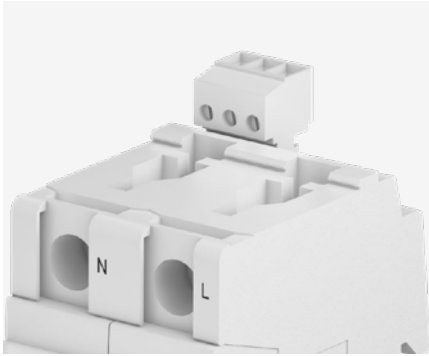

OVR series is using same terminal as Pro M compact devices to guarantee a complete coordination and time saving in wiring operation. All devices allow connection through busbars, both from top and bottom terminals.



The pluggable feature of ABB **OVR T1-T2, T2 and T2-T3** surge protective devices (SPDs) facilitates maintenance. Should one or more worn cartridges need to be replaced, the electrical circuit does not have to be isolated nor do the wires have to be removed.



The end-of-life indicator of the SPD signals the status of the device. A mechanical indicator turns from green to red when the SPD reaches the end of its life, when the end-of-life indicator is fitted.



The toggle of the miniature circuit breaker indicates the status of the **OVR Plus** range. If the toggle is on, the surge protection is active. If the toggle is off and can be switched on again, the device has protected your equipment. If the toggle is off and cannot be switched on, the device must be changed.



A safety reserve system for an extended protection. T1-T2s and T2s. These Surge Protective Devices are equipped with two varistors per pole. If one varistor is damaged, the SPD gives advanced warning that it is approaching the end of its life while the other varistor continues to protect the equipment, allowing to perform Preventive Maintenance.



QuickSafe MOV technology extended to SPD dedicated to D.C photovoltaic applications, bringing soft-protected feature (no back-up needed) up to 10 kA PV short circuit current.

# Circuit Monitoring System

## System overview

The quality of a Circuit Monitoring System is dependent on the strengths of the individual components and how well they interact. ABB's CMS sets the bar particularly high. Regardless of whether we're talking compactness, technology,

measurement results, user friendliness or flexibility, every component and every feature of this CMS has been fully optimized in terms of practicality and functionality.

**Example illustration:**  
Control Unit CMS-700 in combination with CMS open-core sensors



CMS-700

**CMS bus interface**  
A bus interface allows up to 32 sensors to be connected to the Control Unit.

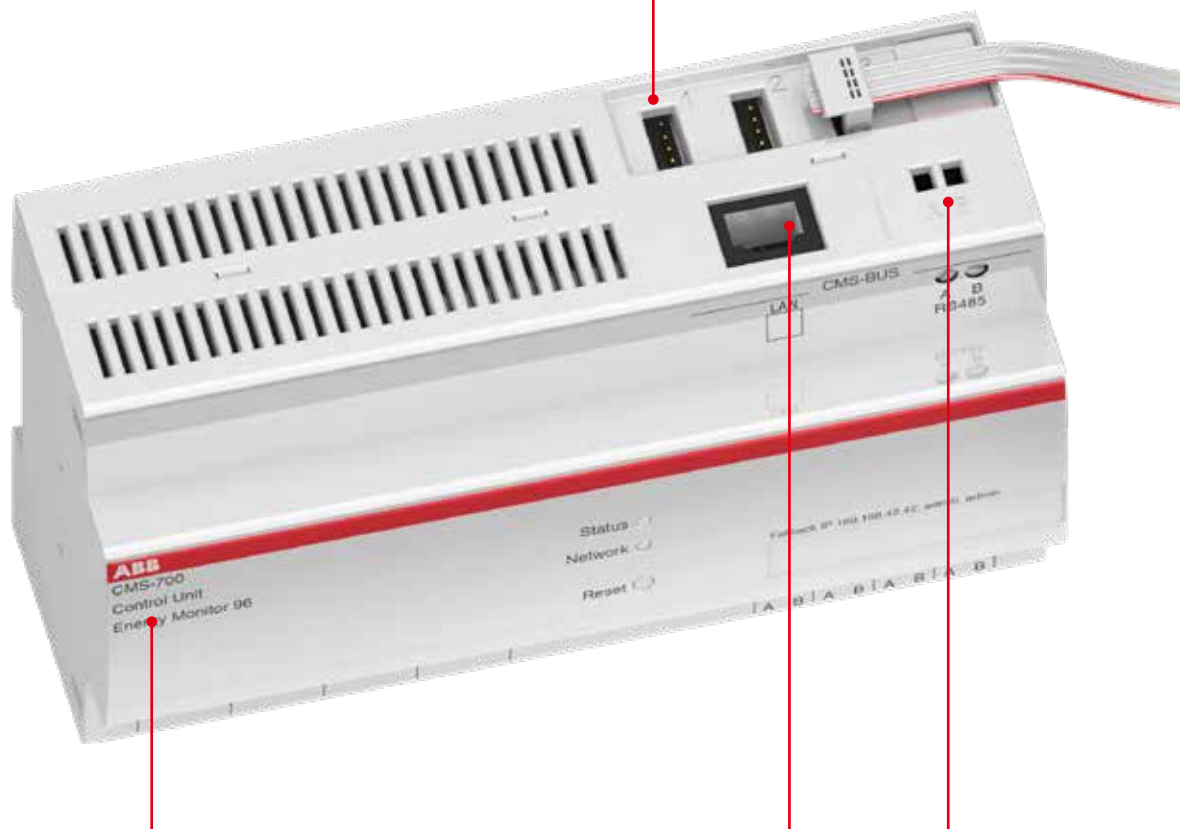

### Control Units

The Control Unit is a kind of computing and communication center that, depending on the equipment connected to it, evaluates the different data picked up by the sensors and makes it available via the built-in interfaces.

You have a choice of three different units depending on your applications: CMS-600 and CMS-700.

### Serial interfaces

Depending on the unit, numerous interfaces and protocols are available to ensure smooth network implementation: RS485 (Modbus RTU), LAN (TCP/IP and Modbus TCP), SNMP v1/v2 and encrypted v3.

Thanks to the built-in web server, an internet browser or a free Android or iOS app can be used to visualize the values measured. What's more, the measured values can also be exported to CSV files.

**Integrate however you want, thanks to multiple mounting options.** Depending on the application, choose between up to four different mounting options to make integrating the CMS sensors in your installation as simple and as uncomplicated as possible.

**Universally usable sensor designs**



**Mounting on a DIN rail**  
CMS-120DR, CMS-100DR, and CMS-200DR series sensors can be mounted on all DIN rails with the aid of a DIN rail mounting.



**Cable tie mounting**  
If space is at a real premium, CMS-120CA, CMS-100CA, and CMS-200CA series sensors can be secured directly to the cable(s) to be measured by means of cable ties.

**Tangible value addition for you ABB circuit monitoring pays off two-fold**

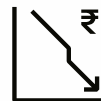

**Early warning system (predictive maintenance) for increasing the availability of critical consumers**  
Continuous monitoring of the current flow at the circuit breaker makes it possible to detect overloaded lines before they lead to a service interruption. Apart from this, monitoring individual circuits indicates whether the loads are in the desired operating mode or not. In this way, system deviations can be ascertained instantaneously. What's more, the CMS can be used to detect unbalanced loads before they result in failure of the neutral conductor and consequently load failure.

**Cost analysis to reduce and assign energy costs**  
The cost of energy will rise continuously. In order to cut costs, you first have to know where they arise. The Control Unit helps illustrate and analyze the instantaneous energy consumption levels. Furthermore, the calculated active energy can be used to roughly allocate the costs at the output level.

**Additional information**

We reserve the right to make technical changes or modify the contents of this document without prior notice.

With regard to purchase orders, the agreed particulars shall prevail. ABB does not accept any responsibility whatsoever for potential errors or possible lack of information in this document.

We reserve all rights in this document and in the subject matter and illustrations contained therein.

Any reproduction, disclosure to third parties or utilization of its contents – in whole or in parts – is forbidden without the prior written consent of ABB.





---

**ABB India Helpline.**

Technical Telephone support for  
customers and channel partners.  
Toll Free: (BSNL) +91 1800 420 07 07.

**[new.abb.com/low-voltage](http://new.abb.com/low-voltage)**

