



GREEN T.HE HIGH EFFICIENCY CAST RESIN TRANSFORMERS

THE GLOBAL SPECIALIST
IN ELECTRICAL AND DIGITAL BUILDING INFRASTRUCTURES







Index

4-6			
General features	Green T.HE cast resin transformers		4
	Advantages of Green T.HE transformers		6
	Certified quality		8
9-13			
Catalogue pages	Resin Green T.HE		9
	12 kV insulation class		10
	17,5 kV insulation class		11
	24 kV insulation class		12
	36 kV insulation class		13
14-15			
Technical informations	Installation accessories		14

GREEN T.HE

cast resin Transformers

With the application in July 2015 of the European Commission Regulation for ecodesign, **efficiency standards of transformers will be more strenght**

The Green T.HE Transformers comply with the EN 50588-1 Standard. They are designed and manufactured according to the Regulation 548/2014 of European Commission and the new Ecodesign guidelines 2009/125/CE.

Legrand Green T.HE Transformers, designed and manufactured in accordance with new Regulation, ensure a consistent reduction in energy consumption, resulting in economic savings and the decrease of CO₂ emissions released into the atmosphere.



The EN 50588-1 Standard applies to 50 Hz, 5 kVA to 40 MVA three-phase dry-type distribution transformers with maximum voltage per component not exceeding 36 kV.

548/2014 Regulation sets out the requirements (mandatory) on ecodesign requirements for electric transformers with a minimum power rating of 1 kVA used in electricity transmission and distribution networks.



CLASSIFICATION

The classification of a cast resin transformer depends on the value of the no-load losses (P_0), as well as the load losses (P_k).

More precisely, P_0 losses are independent from the load and remain constant for the whole period the transformer is connected to the electric power network. On the other hand, P_k losses only occur when the transformer is connected to a load and they are proportional to the square of the load.

NO-LOAD LOSSES (P_0)	LOAD LOSSES (P_k)
A_0	A_k
A_0	B_k

ECODESIGN REQUIREMENTS

Rated power (kVA)	STEP 1 (from 1 July 2015)		STEP 2 (from 1 July 2021)	
	Maximum load losses P_k (W)	Maximum no-load losses P_0 (W)	Maximum load losses P_k (W)	Maximum no-load losses P_0 (W)
≤ 50	B_k (1700)	A_0 (200)	A_k (1500)	$A_0 - 10\%$ (180)
100	B_k (2050)	A_0 (280)	A_k (1800)	$A_0 - 10\%$ (252)
160	B_k (2900)	A_0 (400)	A_k (2600)	$A_0 - 10\%$ (360)
250	B_k (3800)	A_0 (520)	A_k (3400)	$A_0 - 10\%$ (468)
400	B_k (5500)	A_0 (750)	A_k (4500)	$A_0 - 10\%$ (675)
630	B_k (7600)	A_0 (1100)	A_k (7100)	$A_0 - 10\%$ (990)
800	A_k (8000)	A_0 (1300)	A_k (8000)	$A_0 - 10\%$ (1170)
1000	A_k (9000)	A_0 (1550)	A_k (9000)	$A_0 - 10\%$ (1395)
1250	A_k (11000)	A_0 (1800)	A_k (11000)	$A_0 - 10\%$ (1620)
1600	A_k (13000)	A_0 (2200)	A_k (13000)	$A_0 - 10\%$ (1980)
2000	A_k (16000)	A_0 (2600)	A_k (16000)	$A_0 - 10\%$ (2340)
2500	A_k (19000)	A_0 (3100)	A_k (19000)	$A_0 - 10\%$ (2790)
3150	A_k (22000)	A_0 (3800)	A_k (22000)	$A_0 - 10\%$ (3420)

Requirements applicable (losses value) to three phase dry type transformers with rated power ≤ 3150 kVA with one winding with $U_m \leq 24$ kV and the other one with $U_m \leq 1,1$ kV.

The transformer purchase price is only a small part of its Total Ownership Cost (TCO), while the Operating Costs (mainly connected with losses), represent over 80% of the TCO.

Buying a transformer designed according to rules environmentally friendly, means reducing the Operating Cost and, consequently, having both an economic and environmental advantage.



Once the transformer has exhausted its own operating cycle, all of the materials can be easily recycled or disposed, as indicated in the PEP (Product Environmental Profile) document.

Said document describes the environmental impact of a product during its entire life cycle (from extraction of the needed raw materials to product disposal).



ADVANTAGES OF Green T.H.E TRANSFORMERS



Low,
partial
discharges,
HIGH Quality



According to the product standard related to design of resin transformers (CEI EN 60076-11, i.e. IEC 60076-11), all the windings with a voltage $\geq 3.6\text{kV}$ should be subjected to the measurement of the partial discharges and the value measured should not exceed 10 picocoulombs (pC).

Partial discharges are a microscopic phenomena occurring inside insulating resin cavities and can speed up ageing.

For this reason, it is important that the values of such currents are limited.

A low value of partial discharges gives an indication of the positive factors, such as:

- a solid design criteria has been applied
- a high quality of raw materials used
- a high precision during the conductor winding phases
- a high competence during the epoxy resin pouring around the high-voltage winding
- a high impregnation coefficient of low voltage coil
- a rigour in final assembling of semi-manufacturers

It is easy to see a coloration between a lower level of partial discharges that leads to a higher resistance to work stresses and consequently to a higher life expectancy of the transformer under examination.

TYPE OF THE PARTIAL DISCHARGES

Depending on the type, discharges can be divided into:

- Corona effect: is the discharge that happen in air or in a gas surrounding a conductor, this usually occurs in relation to points and edges present on the conductors.
- Surface discharges: it occurs on the surface of an insulator and which generally causes damage on the surface of the insulation itself, reducing the efficiency
- Internal discharges: represents the main cause of life-cycle decrease of the insulating material)
- Treeing (branched discharge channel): is the channel of pre-discharge which is formed following the degradation of the insulation and which leads to a destructive discharge.



Reliability guaranteed

With Green T.HE series, Legrand provides customers a top-quality product which guarantees long-term excellent performance and reliability.

When the Green T.HE transformers are subjected to partial discharges (according to CEI 60076-11, i.e. IEC 60076-11), values under 5 pC have been always been achieved (which exceeds the requirement of the standard which establishes the maximum value at 10 pC).



(*) standard features:
all transformers according to the European Directive 548/2014 and with the code starting with "F", such as FK4AAAGBA Green T.HE-eu AA
KVA 1000 kV 20/0,4.
All the transformer accessories shown on pages 14 and 15 of this catalogue are expressly excluded from the guarantee extension.

CERTIFIED QUALITY



Certifications

The Legrand test lab “IB03” has recently received the qualification by ACAE to work according to the 17025 standard on all routine tests and on some tests for medium-voltage transformers.

Such acknowledgement and qualification is a very important plus obtained and Legrand with few others around the world can offer this to their customers.

Every cast resin transformer is tested before the delivery to the customer.

ACCEPTANCE TESTS

■ Measurement of winding resistance	IEC 60076-11 (clause 15)
■ Measurement of voltage ratio and check of phase displacement	IEC 60076-11 (clause 16)
■ Measurement of short-circuit impedance and load loss	IEC 60076-11 (clause 17)
■ Measurement of no-load loss and current	IEC 60076-11 (clause 18)
■ Separate-source AC withstand voltage test	IEC 60076-11 (clause 19)
■ Induced AC withstand voltage test	IEC 60076-11 (clause 20)
■ Partial discharge measurement	IEC 60076-11 (clause 22)

TYPE TESTS (on request)

■ Lightning impulse test	IEC 60076-11 (clause 21)
■ Temperature-rise test	IEC 60076-11 (clause 23)

SPECIAL TESTS (on request)

■ Measurement of sound level	IEC 60076-11 (clause 24)
■ Short-circuit test	IEC 60076-11 (clause 25)

Resin Green T.HE

Compliance with standard: IEC 60076-11 and EN 50588-1
 Power (kVA): 100–3150
 Frequency (Hz): 50
 Adjustment, MT side: $\pm 2 \times 2.5\%$
 Thermal class of the insulating system: 155 °C (F) / 155 °C (F)
 Temperature rise: 100/100 K
 Class of use: E2-C2-F1 Certified CESI A9032391 IEC 60076-11
 Tolerances on losses: 0%
 Other tolerances: According to IEC/CEI

Primary voltages (kV): 6-10-11. Insulation class: 12 kV BIL 60 kV
 (BIL 75 kV available on request at no extra charge,
 to be specified at the time of order)
 Secondary voltages no-load (V): 400-433 (insulation class 1.1 kV)

Primary voltages (kV): 12-13,2-15. Insulation class: 17,5 kV BIL 75 kV
 (BIL 95 kV available on request at no extra charge,
 to be specified at the time of order)

Secondary voltages no-load (V): 400-410-420 (insulation class 1.1 kV)
 Primary voltages (kV): 20-23. Insulation class: 24 kV BIL 95 kV
 (BIL 125 kV available on request at no extra charge,
 to be specified at the time of order)
 Secondary voltages no-load (V): 400-410-420 (insulation class 1.1 kV)

Primary voltages (kV): 25-33. Insulation class: 36 kV BIL 170 kV
 Secondary voltages no-load (V): 400-420 (insulation class 1.1 kV)

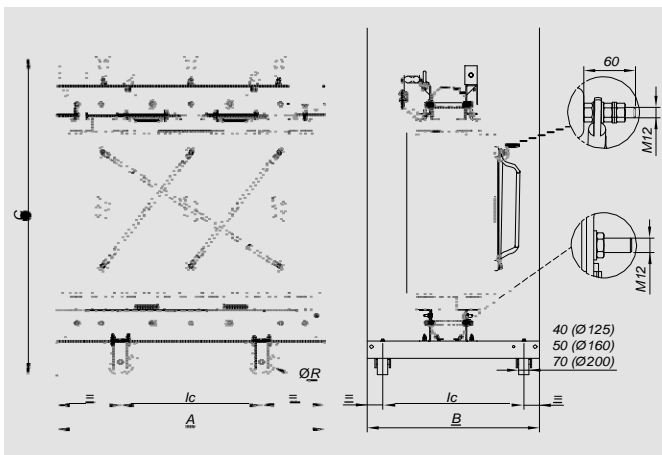

Values are for reference only. Construction drawings must be used for design.
 Data provided may be modified without warning for reasons of technical production or product improvement.

Possibility to build (on request) products with other combinations of primary and secondary voltage.



Insulation class

12 kV

S _R [kVA]	Series (Reg548)	Item	Uk [%]	Primary voltage [kV]	Secondary voltage [V]	Po [W]	Pk [W] a 120 °C	Io [%]	LwA-Acoustic power [dB (A)]	Length (A) [mm]	Width (B) [mm]	Height (C) [mm]	Ic - wheel centre line [mm]	R - wheel diameter [mm]	Weight [kg]	BOX type*
100	AoAk	FB2AAACBA	6	10	400	280	1800	1,8	51	1200	600	1260	520	125	830	2
	AoBk	FB2ABACBA	6	10	400	280	2050	1,8	51	1200	600	1200	520	125	800	2
160	AoAk	FC2AAACBA	6	10	400	400	2600	1,6	54	1200	600	1350	520	125	950	2
	AoBk	FC2ABACBA	6	10	400	400	2900	1,6	54	1250	600	1300	520	125	1000	2
200	AoAk	FD2AAACBA	6	10	400	450	2955	1,4	55	1250	600	1360	520	125	1050	3
	AoBk	FD2ABACBA	6	10	400	450	3300	1,4	55	1250	600	1350	520	125	1100	3
250	AoAk	FE2AAACBA	6	10	400	520	3400	1,2	57	1350	600	1380	520	125	1200	3
	AoBk	FE2ABACBA	6	10	400	520	3800	1,2	57	1300	600	1400	520	125	1250	3
315	AoAk	FF2AAACBA	6	10	400	615	3875	1,1	58	1350	750	1450	670	125	1350	3
	AoBk	FF2ABACBA	6	10	400	615	4535	1,1	58	1350	750	1450	670	125	1350	3
400	AoAk	FG2AAACBA	6	10	400	750	4500	1	60	1350	750	1560	670	125	1350	4
	AoBk	FG2ABACBA	6	10	400	750	5500	1	60	1350	750	1560	670	125	1500	4
500	AoAk	FH2AAACBA	6	10	400	900	5630	0,9	60	1350	750	1670	670	125	1650	4
	AoBk	FH2ABACBA	6	10	400	900	6410	0,9	60	1400	750	1650	670	125	1650	4
630	AoAk	FI2AAACBA	6	10	400	1100	7100	0,9	62	1450	850	1700	670	160	2000	5
	AoBk	FI2ABACBA	6	10	400	1100	7600	0,9	62	1450	850	1760	670	160	1950	5
800	AoAk	FJ2AAACBA	6	10	400	1300	8000	0,8	64	1500	850	1880	670	160	2350	5
1000	AoAk	FK2AAACBA	6	10	400	1550	9000	0,7	65	1600	1000	2020	820	160	2900	6
1250	AoAk	FL2AAACBA	6	10	400	1800	11000	0,7	67	1650	1000	2150	820	160	3300	6
1600	AoAk	FM2AAACBA	6	10	400	2200	13000	0,5	68	1800	1000	2220	820	160	4050	7
2000	AoAk	FN2AAACBA	6	10	400	2600	16000	0,5	70	1900	1310	2270	1070	200	4800	7
2500	AoAk	FO2AAACBA	6	10	400	3100	19000	0,4	71	2050	1400	2430	1070	200	5950	8
3150	AoAk	FP2AAACBA	6	10	400	3800	22000	0,4	74	2150	1400	2450	1070	200	7000	8

* For boxes information see p. 15

Insulation class

17,5 kV

S _r [kVA]	Series (Reg548)	Item	U _k [%]	Primary voltage [kV]	Secondary voltage [V]	P _o [W]	P _k [W] a 120 °C	Io [%]	LwA-Acoustic power [dB (A)]	Length (A) [mm]	Width (B) [mm]	Height (C) [mm]	Ic - wheel centre line [mm]	R - wheel diameter [mm]	Weight [kg]	BOX type*
100	AoAk	FB3AAAFBA	6	15	400	280	1800	1,8	51	1250	600	1250	520	125	850	2
	AoBk	FB3ABAFBA	6	15	400	280	2050	1,8	51	1200	600	1200	520	125	850	2
160	AoAk	FC3AAAFBA	6	15	400	400	2600	1,6	54	1300	600	1330	520	125	1050	2
	AoBk	FC3ABAFBA	6	15	400	400	2900	1,6	54	1250	600	1300	520	125	1050	2
200	AoAk	FD3AAAFBA	6	15	400	450	2955	1,4	55	1350	600	1350	520	125	1150	3
	AoBk	FD3ABAFBA	6	15	400	450	3300	1,4	55	1250	600	1300	520	125	1150	3
250	AoAk	FE3AAAFBA	6	15	400	520	3400	1,2	57	1350	600	1380	520	125	1250	3
	AoBk	FE3ABAFBA	6	15	400	520	3800	1,2	57	1350	600	1300	520	125	1300	3
315	AoAk	FF3AAAFBA	6	15	400	615	3875	1,1	58	1350	750	1440	670	125	1350	3
	AoBk	FF3ABAFBA	6	15	400	615	4535	1,1	58	1350	750	1400	670	125	1350	3
400	AoAk	FG3AAAFBA	6	15	400	750	4500	1	60	1450	750	1550	670	125	1600	4
	AoBk	FG3ABAFBA	6	15	400	750	5500	1	60	1350	750	1520	670	125	1450	4
500	AoAk	FH3AAAFBA	6	15	400	900	5630	0,9	60	1450	750	1680	670	125	1750	4
	AoBk	FH3ABAFBA	6	15	400	900	6410	0,9	60	1400	750	1600	670	125	1700	4
630	AoAk	FI3AAAFBA	6	15	400	1100	7100	0,9	62	1550	850	1800	670	160	2100	5
	AoBk	FI3ABAFBA	6	15	400	1100	7600	0,9	62	1500	850	1750	670	160	2050	5
800	AoAk	FJ3AAAFBA	6	15	400	1300	8000	0,8	64	1550	850	1890	670	160	2450	5
1000	AoAk	FK3AAAFBA	6	15	400	1550	9000	0,7	65	1650	1000	2050	820	160	3050	6
1250	AoAk	FL3AAAFBA	6	15	400	1800	11000	0,7	67	1700	1000	2160	820	160	3550	6
1600	AoAk	FM3AAAFBA	6	15	400	2200	13000	0,5	68	1850	1000	2240	820	160	4400	7
2000	AoAk	FN3AAAFBA	6	15	400	2600	16000	0,5	70	2000	1310	2300	1070	200	5300	7
2500	AoAk	FO3AAAFBA	6	15	400	3100	19000	0,4	71	2150	1400	2430	1070	200	6100	8
3150	AoAk	FP3AAAFBA	6	15	400	3800	22000	0,4	74	2300	1400	2550	1070	200	8000	8

* For boxes information see p. 15

Insulation class

24 kV

S _r [kVA]	Series (Reg548)	Item	U _k [%]	Primary voltage [kV]	Secondary voltage [V]	P _o [W]	P _k [W] a 120 °C	I _o [%]	LwA-Acoustic power [dB (A)]	Length (A) [mm]	Width (B) [mm]	Height (C) [mm]	Ic - wheel centre line [mm]	R - wheel diameter [mm]	Weight [kg]	BOX type*
100	AoAk	FB4AAAGBA	6	20	400	280	1800	1,8	51	1250	600	1300	520	125	900	2
	AoBk	FB4ABAGBA	6	20	400	280	2050	1,8	51	1250	600	1250	520	125	900	2
160	AoAk	FC4AAAGBA	6	20	400	400	2600	1,6	54	1250	600	1360	520	125	1050	2
	AoBk	FC4ABAGBA	6	20	400	400	2900	1,6	54	1250	600	1300	520	125	1050	2
200	AoAk	FD4AAAGBA	6	20	400	450	2955	1,4	55	1350	600	1370	520	125	1200	3
	AoBk	FD4ABAGBA	6	20	400	450	3300	1,4	55	1350	600	1300	520	125	1200	3
250	AoAk	FE4AAAGBA	6	20	400	520	3400	1,2	57	1350	600	1410	520	125	1350	3
	AoBk	FE4ABAGBA	6	20	400	520	3800	1,2	57	1350	600	1350	520	125	1350	3
315	AoAk	FF4AAAGBA	6	20	400	615	3875	1,1	58	1350	750	1470	670	125	1450	3
	AoBk	FF4ABAGBA	6	20	400	615	4535	1,1	58	1350	750	1400	670	125	1450	3
400	AoAk	FG4AAAGBA	6	20	400	750	4500	1	60	1450	750	1570	670	125	1700	4
	AoBk	FG4ABAGBA	6	20	400	750	5500	1	60	1450	750	1570	670	125	1600	4
500	AoAk	FH4AAAGBA	6	20	400	900	5630	0,9	60	1450	750	1700	670	125	1800	4
	AoBk	FH4ABAGBA	6	20	400	900	6410	0,9	60	1450	750	1650	670	125	1800	4
630	AoAk	FI4AAAGBA	6	20	400	1100	7100	0,9	62	1550	850	1820	670	160	2150	5
	AoBk	FI4ABAGBA	6	20	400	1100	7600	0,9	62	1550	850	1820	670	160	2150	5
800	AoAk	FJ4AAAGBA	6	20	400	1300	8000	0,8	64	1550	850	1920	670	160	2550	5
1000	AoAk	FK4AAAGBA	6	20	400	1550	9000	0,7	65	1650	1000	2090	820	160	3150	6
1250	AoAk	FL4AAAGBA	6	20	400	1800	11000	0,7	67	1750	1000	2180	820	160	3650	6
1600	AoAk	FM4AAAGBA	6	20	400	2200	13000	0,5	68	1900	1000	2260	820	160	4600	7
2000	AoAk	FN4AAAGBA	6	20	400	2600	16000	0,5	70	2000	1310	2320	1070	200	5550	7
2500	AoAk	FO4AAAGBA	6	20	400	3100	19000	0,4	71	2150	1310	2450	1070	200	6300	8
3150	AoAk	FP4AAAGBA	6	20	400	3800	22000	0,4	74	2300	1400	2560	1070	200	8100	8

* For boxes information see p. 15

Insulation class

36 kV

S _R [kVA]	Series (Reg548)	Item	U _k [%]	Primary voltage [kV]	Secondary voltage [V]	P _o [W]	P _k [W] a 120 °C	I _o [%]	LwA-Acoustic power [dB (A)]	Length (A) [mm]	Width (B) [mm]	Height (C) [mm]	Ic - wheel centre line [mm]	R - wheel diameter [mm]	Weight [kg]	BOX type*
160	AoAk	FC5AAAQBA	6,5	33	400	460	2860	1,5	57	1650	750	1600	670	125	1650	3
	AoBk	FC5ABAQBA	6,5	33	400	460	3190	1,5	57	1650	750	1650	670	125	1700	3
200	AoAk	FD5AAAQBA	6,5	33	400	515	3250	1,4	57	1650	750	1700	670	125	1850	3
	AoBk	FD5ABAQBA	6,5	33	400	515	3630	1,4	57	1650	750	1750	670	125	1850	3
250	AoAk	FE5AAAQBA	6,5	33	400	595	3740	1,3	59	1650	850	1750	670	160	1900	4
	AoBk	FE5ABAQBA	6,5	33	400	595	4180	1,3	59	1650	850	1800	670	160	1950	4
315	AoAk	FF5AAAQBA	6,5	33	400	705	4260	1,2	59	1650	850	1800	670	160	2100	4
	AoBk	FF5ABAQBA	6,5	33	400	705	4985	1,2	59	1650	850	1850	670	160	2100	4
400	AoAk	FG5AAAQBA	6,5	33	400	860	4950	1,1	61	1700	850	1850	670	160	2200	5
	AoBk	FG5ABAQBA	6,5	33	400	860	6050	1,1	61	1650	850	1900	670	160	2300	5
500	AoAk	FH5AAAQBA	6,5	33	400	1035	6190	1,1	61	1750	850	1950	670	160	2550	5
	AoBk	FH5ABAQBA	6,5	33	400	1035	7050	1,1	61	1650	850	2000	670	160	2550	5
630	AoAk	FI5AAAQBA	6,5	33	400	1265	7810	1	63	1800	1000	2000	820	160	2800	6
	AoBk	FI5ABAQBA	6,5	33	400	1265	8360	1	63	1700	1000	2050	820	160	2850	6
800	AoAk	FJ5AAAQBA	6,5	33	400	1495	8800	0,9	64	1850	1000	2100	820	160	3400	6
1000	AoAk	FK5AAAQBA	6,5	33	400	1780	9900	0,8	65	1950	1000	2200	820	160	3700	6
1250	AoAk	FL5AAAQBA	6,5	33	400	2070	12100	0,7	67	2000	1000	2350	820	160	4500	7
1600	AoAk	FM5AAAQBA	6,5	33	400	2530	14300	0,6	68	2150	1310	2400	1070	200	5300	7
2000	AoAk	FN5AAAQBA	6,5	33	400	2990	17600	0,6	72	2300	1310	2500	1070	200	6600	8
2500	AoAk	FO5AAAQBA	6,5	33	400	3565	20900	0,5	73	2500	1310	2600	1070	200	7500	8

* For boxes information see p. 15



Cat. Nos.	Ventilation bars		
	The ventilation busbars temporarily increase the rated power (under normal service conditions). According to standard IEC 60076-1, a transformer is called AN even if it is equipped with discontinuous ventilation. If a transformer with AF continuous service is requested, it is not possible to refer to the codes included in this catalogue, but the transformer will be designed according to the customer's needs.		
	Range (kVA)	ΔPower (%)	Notes
CB02444	100 - 250	+ 40	A temporary increase in rated conditions
CB02454	315 - 800	+ 40	
CB02464	1000 - 1250	+ 40	
CB01414	1600 - 2500	+ 30	
CB01412	3150	+ 20	

Cat. Nos.	Surge arrester kit	
	Vn (kV)	
130075D	6	
130054D	10-11	
130055D	15	
130056D	20	

Cat. Nos.	Range (kVA)	Description
170019	≤1600	4 buffers supplied for mounting under the transformer casters
170020	≥2000	4 buffers supplied for mounting under the transformer casters

Temperature measurement probes					
Probes are supplied mounted on to the transformer and wired to aluminium IP 66 junction box.					
	Type	Range (kVA)	N°	Δt (°C)	Installation
200073	Pt100	≤2000	3	-	on the LV (3) windings
200074	Pt100	≥2500	3	-	on the LV (3) windings
200137	Pt100	≤2000	3+1	-	on the LV (3) windings + on the core (1)
200138	Pt100	≥2500	3+1	-	on the LV (3) windings + on the core (1)
CB0012	PTC	-	3+3	130-140	on the LV (3 pairs) windings for alarm and release.
CB0240	PTC	-	3+3	110-120	on the LV (3 pairs) windings for alarm and release.
CB0272	PTC	-	3+3+3	110-130 -140	on the LV (3 pairs) windings for fan control, for alarm and release.

Rubber supports (anti vibration)		
	Range (kVA)	Description
170019	≤1600	4 buffers supplied for mounting under the transformer casters
170020	≥2000	4 buffers supplied for mounting under the transformer casters

Cupal plates		
Cupal is a bimetal sheet made up of one copper sheet and one aluminium sheet inseparably welded together through a special mechanical procedure.		
	Range (kVA)	Description
030014 *	≤ 160	40 x 40 CUPAL plate
030008 *	≥ 200 and ≤ 315	50 x 50 CUPAL plate
030009 *	≥ 400 and ≤ 630	60 x 60 CUPAL plate
030010 *	800	80 x 80 CUPAL plate
030011 *	1000	100 x 100 CUPAL plate
030012 *	≥ 1250	120 x 120 CUPAL plate

Note: * the codes refer to a single CUPAL plate

Example:
 - Power = 1250 kVA corresponds to the CUPAL plate code item 030012
 - Quantity calculation: 2 plates x 4 BT terminals = 8 CUPAL plates

Temperature control devices		
Central units are supplied unassembled		
	Type	Description
220035	VRT200	fan control
220002	T154	temperature control for 4 Pt100 probes
220023	MT200L	temperature control for 4 Pt100 probes
220010	T119 DIN	temperature control for 6 PTC probes, preset for DIN rail mounting
220004	T 119	temperature control for 6 PTC probes
220174	AT100	fan control
220197	NT935	temperature control for 4 Pt100 probe with analogue and digital output

Green T.HE cast resin transformers

Installation accessories



BOXES
RAL 7035 colour
AREL door lock on the box, Cat. Nos. 230076

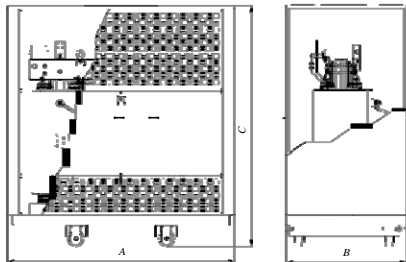

Class 12kV-17,5kV-24kV							
Cat. Nos.	Box type	IP degree	Dimensions (mm)			Weight (kg)	Power** [kVA]
			Length (A)	Width (B)	Height (C)		
230273	2	23	1700	950	1580	140	100-160
230263	2	31	1700	950	1580	140	
230215	3	23	1800	1000	1680	160	200-250-315
230234	3	31	1800	1000	1680	160	
230277	4	23	1900	1050	1950	180	400 -500
230222	4	31	1900	1050	1950	180	
230221	5	23	2050	1100	2200	210	630 - 800
230223	5	31	2050	1100	2200	210	
230267	6	23	2300	1310	2500	280	1000 - 1250
230249	6	31	2300	1310	2500	280	
230309	7	23	2500	1310	2700	300	1600 - 2000
230371	7	31	2500	1310	2700	300	
231044	8	23	2700	1400	2900	350	2500 - 3150
231043	8	31	2700	1400	2900	350	
Class 36kV							
231120	3	23	2200	1400	2050	240	160 - 200
231119	3	31	2200	1400	2050	240	
231123	4	23	2300	1400	2150	250	250 - 315
230665	4	31	2300	1400	2150	250	
231124	5	23	2450	1450	2500	300	400 - 500
230667	5	31	2450	1450	2500	300	
231125	6	23	2600	1500	2700	330	630 - 800 - 1000
230669	6	31	2600	1500	2700	330	
231122	7	23	2900	1700	2800	400	1250-1600
231121	7	31	2900	1700	2800	400	
231128*	8	23	3100	2000	3000	750	2000 - 2500
231127*	8	31	3100	2000	3000	750	

* Resting on the ground and assembled on the transformer.

Boxes can be supplied separately or assembled on the transformer. If you required the box pre-assembled add the "M" suffix to the code (e.g. 231043M).

** The power transformer is corresponds to the type of box and is meant for transformers without surge arresters and without connections to the busbar.

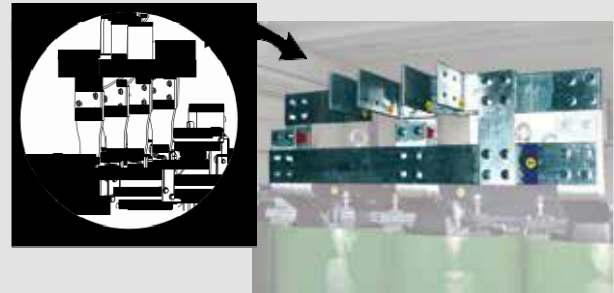

SIZES AND DRILLING OF LV CONNECTION TERMINALS

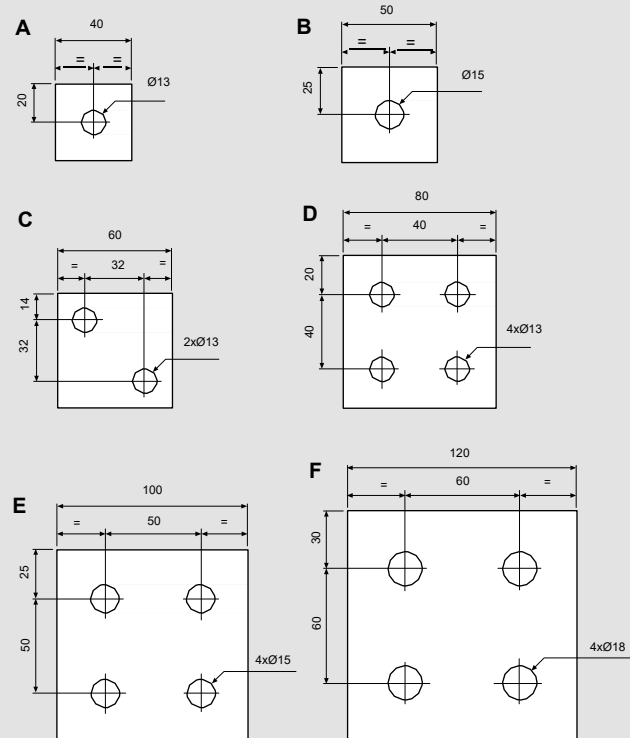

DRILLING STANDARD

LV connection terminals are manufactured from aluminium. Special CUPAL bimetallic plates can be supplied for the connection of copper cables.

Drawing	Range (kVA)	Thickness (mm)
A	100	4
	160	4
B	200	5
	250	5
C	315	5
	400	6
	500	8
D	800	8
	630	8
	800	8
E	1000	10
F	1250	10
	1600	12
	2000	16
	2500	20
	3150	24

Legrand reserves the right to modify the content of this booklet at any time and to communicate, in any form and modality, the changes brought to the same.



FOLLOW US ALSO ON

@ www.legrand.com

 www.youtube.com/legrand

 twitter.com/@legrand



Head office
and International Department
87045 Limoges Cedex - France
Tel.: + 33 (0) 5 55 06 87 87
Fax: + 33 (0) 5 55 06 74 55