

Attracting Tomorrow



TDK India Product Profile

Power Quality Solutions

Power Factor Correction and Harmonic Filtering



<https://in.tdk-electronics.tdk.com>



TDK India Pvt. Ltd. (formally EPCOS India Pvt. Ltd.) is a member of the TDK Corporation, Japan. While TDK is the second largest producer of passive components in the world, EPCOS came into existence in 1999 as a spin off from mother company Siemens and was taken over by TDK in 2008.

With its broad portfolio, TDK offers a comprehensive range of products from a single source and focuses on future oriented, technologically demanding applications of information and communication technology, automotive electronics, industrial and consumer electronics. With global revenue of approx. USD 12 billion, TDK has over 110 design, manufacturing and sales offices spread across Europe, Japan, Asia, North and South America.

The company has been selling components in India since the 1960s under the umbrella of Siemens, then EPCOS and now TDK. TDK has three

world class manufacturing units in India since early 90's located in Kalyani West Bengal (for soft ferrites), in Nasik - Maharashtra (for Plastic film capacitors). Apart from 2 plants, TDK has 4 regional offices, 8 home offices, over 100 channel partners and employs over 3000 people in India.

TDK's product portfolio includes film capacitors (DC capacitors, AC motor run, Filter capacitors, DC Link capacitors, PFC capacitors, and MV capacitors), MV RPC Systems, Power Quality Solutions, aluminum electrolytic, ceramic capacitors, soft ferrites, inductors, chokes, coils, transformers, piezo and protection components like NTC, PTC, MOV, Surge arrestors, Zinc Oxide blocks, GD Tubes, piezo haptic devices, temperature and pressure sensors, inertial and gyrometric sensors, MEMS devices, Mobile phone batteries, IOT enabled wearable devices, magnets, recording devices, Flash memory applied devices, Radio wave

anechoic chambers, EMC measuring system, various products for mobile phones like camera actuators, MEMS Microphones, ITO film for touch panels etc. The company markets the product under 2 different bands of EPCOS and TDK.

In India the company produces metallized plastic film capacitors, AC motor run capacitors, Filter capacitors, LV PFC capacitors, key components required for PF correction system, APFC panels, MV capacitors, MV capacitor switch, MV reactive power compensation system.

TDK plants are certified to ISO 9001, ISO/TS 16949, IRIS and ISO 14001. The products have global approvals like UL, VDE, CSA, TUV, BIS, etc. and these products are exported to over 40 countries worldwide.

Index

Contents	Page
Preview	4
PFC capacitor series overview	6
PQS Key components overview	8
Important notes	10
PFC capacitors	
PhaseCap Energy HD	11
PhaseCap Super Heavy Duty	17
PhiCap	23
SquareCap	28
LT-APP	36
PF controllers and measuring devices	
BR6000 series	39
BR5000 series	42
BR4000 ER series	46
BR2100 series	47
BR4000 S series	49
Switching devices	
Capacitor duty contactors	52
Thyristor modules for dynamic PFC (TSM-series)	55
Buffer card	58
Reactors	
Reactors - Antiresonance harmonic filter	59
Detuned PFC	
AL and CU COMBO codes for instant selection	62
PQSine	
Active Harmonic Filter and Power Optimizer	63
PQS-LVSS	
TDK APFC Panels	73
Fundamentals of power factor correction	81
Components of Power Factor Correction	82
Standard Values: Selection Tables for cables, cable cross sections and fuses	85
Capacitor selection chart	87
Individual PFC for motors	88
Individual PFC for transformers	89
Detuned PFC in general	90
Detuned PFC important facts and instructions	91
Capacitor voltage rating selection guideline	92
Dynamic PFC important facts and instructions	95
PFC basic formulae	96
Cautions	99

Preview

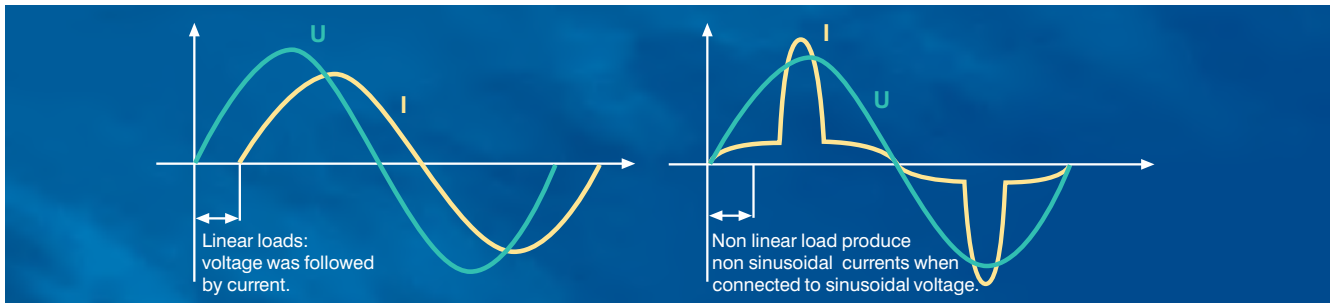

General

The increasing demand of electrical power and the awareness of the necessity of energy saving is very up to date these days. Also the awareness of power quality is increasing, and power factor correction (PFC) and harmonic filtering will be implemented on a growing scale. Enhancing power quality – improvement of power factor – saves costs and ensures a fast return on investment. In power distribution, in low- and medium-voltage networks, PFC focuses on the power flow ($\cos \phi$) and the optimization of voltage stability by generating reactive power – to improve voltage quality and reliability at distribution level.

How reactive power is generated

Every electric load that works with magnetic fields (motors, chokes, transformers, inductive heating, arc welding, generators) produces a varying degree of electrical lag, which is called inductance. This lag of inductive loads maintains the current sense (e.g. positive) for a time even though the negative-going voltage tries to reverse it. This phase shift between current and voltage is maintained, current and voltage having opposite signs. During this time, negative power or energy is produced and fed back into the network. When current and voltage have the same sign again, the same amount of energy is again needed to build up the magnetic fields in inductive loads. This magnetic reversal energy is called reactive power.

In AC networks (50/60 Hz) such a process is repeated 50 or 60 times a second. So an obvious solution is to briefly store the magnetic reversal energy in capacitors and relieve the network (supply line) of this reactive energy. For this reason, automatic

reactive power compensation systems (detuned /conventional) are installed for larger loads like industrial machinery. Such systems consist of a group of capacitor units that can be cut in and cut out and which are driven and switched by a power factor controller.

$$\text{Apparent power } S = \sqrt{P^2 + Q^2}$$

$$\text{Active power } P = S \cdot \cos \phi$$

$$\text{Reactive power } Q = S \cdot \sin \phi$$

With power factor correction the apparent power S can be decreased by reducing the reactive power Q.

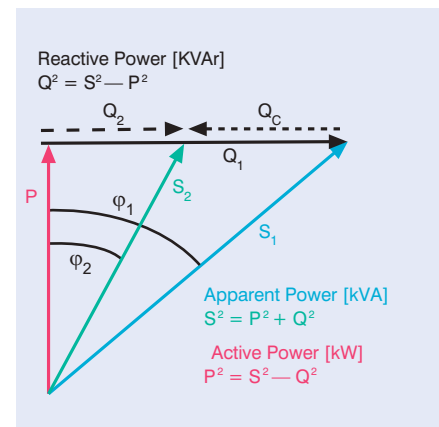

Power factor

Low power factor ($\cos \phi$)

Low $\cos \phi$ results in

- Higher energy consumption and costs,
- Less power distributed via the network,
- Power loss in the network,
- Higher transformer losses,
- Increased voltage drop in power distribution networks.

Power factor improvement

Power factor improvement can be achieved by

- Compensation of reactive power with capacitors,
- Active compensation – using semiconductors,
- Overexcited synchronous machine (motor/generator).

Types of PFC

(detuned or conventional)

- individual or fixed compensation (each reactive power producer is individually compensated),
- group compensation (reactive power producers connected as a group and compensated as a whole),
- central or automatic compensation (by a PFC system at a central point),
- mixed compensation.

Preview



Power Quality Solution strategy

Along with the emerging demand for power quality and a growing awareness of the need for environmental protection, the complexity in the energy market is increasing: users and decision-makers are consequently finding it increasingly difficult to locate the best product on the market and to make objective decisions. It is in most cases not fruitful to compare catalogs and data sheets, as many of their parameters are identical in line with the relevant standards. Thus operating times are specified on the basis of

tests under laboratory conditions that may differ significantly from the reality in the field. In addition, load structures have changed from being mainly linear in the past to non-linear today. All this produces a clear trend: the market is calling increasingly for customized solutions rather than off-the-shelf products. This is where Power Quality Solutions come into the picture. It offers all key components for an effective PFC system from a single source, together with:

- Application know-how
- Technical skills
- Extensive experience in the field of power quality improvement
- A worldwide network of partners
- Continuous development
- Sharing of information

These are the cornerstones on which Power Quality Solutions are built. On the basis of this strategy, TDK is not only the leading manufacturer of power capacitors for PFC applications but also a PQS supplier with a century of field experience, reputation and reliability.

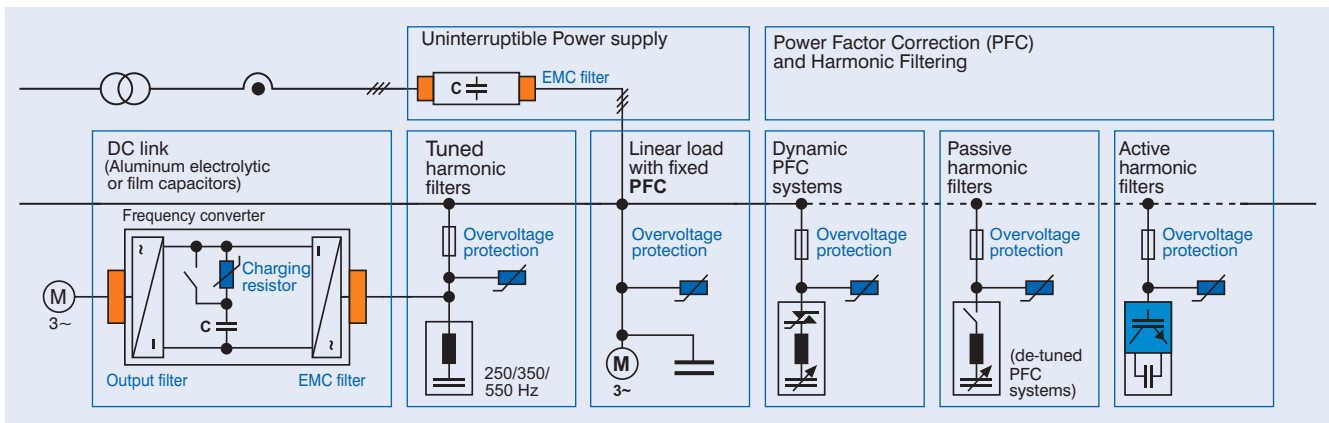

PFC Capacitor Series Overview

PFC capacitor series for power factor correction capacitors			
PhaseCap Energy HD		B25674L . . .	
Power	KVAr	5...33.1	
Voltage range	V	415...800 V*	
Frequency	Hz	50Hz	
Impregnation		Gas-impregnated, dry type, Non-PCB	
Life expectancy	Hrs	Up to 150 000 h for -40/D°C	
Inrush current	A	400 • I _R	
PhaseCap Super Heavy Duty		B25675L . . .	
Power	KVAr	1...37.1	
Voltage range	V	415...1000 V*	
Frequency	Hz	50 Hz	
Impregnation		Non-PCB, semi-dry biodegradable resin	
Life expectancy	Hrs	Up to 200 000 h for -40/D°C Up to 180 000 h for -40/60°C	
Inrush current	A	500 • I _R	
PhiCap ND		B32343F . . . /B32344F . . .	
Power	KVAr	0.5...33.1	
Voltage range	V	230...525 V*	
Frequency	Hz	50 Hz	
Impregnation		Non-PCB, semi-dry biodegradable resin	
Life expectancy	Hrs	Up to 100 000 hours	
Inrush current	A	200 • I _R	
PhiCap 1Ph		B32340. . . /B32341. . .	
Power	KVAr	0.5...8.33	
Voltage range	V	400...525V*	
Frequency	Hz	50 Hz	
Impregnation		Non-PCB, semi dry biodegradable resin/Gas	
Life expectancy	Hrs	Upto 100000 Hrs	
Inrush current	A	250 I _R	





*Other voltages on request.

PFC Capacitor Series Overview

PFC capacitor series for power factor correction capacitors			
SquareCap-ENDC		B32457L . . .	
Power	KVAr	1...50.0	
Voltage range	V	415...440 V*	
Frequency	Hz	50 Hz	
Impregnation		Non-PCB, semi-dry biodegradable resin	
Life expectancy	Hrs	Up to 100 000 hours	
Inrush current	A	100 • I _R	
SquareCap-EHDLL		B32459L . . .	
Power	KVAr	1...60.0	
Voltage range	V	415...525 V*	
Frequency	Hz	50 Hz	
Impregnation		Non-PCB, semi-dry biodegradable resin	
Life expectancy	Hrs	Up to 125 000 hours	
Inrush current	A	250 • I _R	
SquareCap-ESHDC		B32455L . . .	
Power	KVAr	1...50.0	
Voltage range	V	415...525 V*	
Frequency	Hz	50 Hz	
Impregnation		Non-PCB, semi-dry biodegradable resin	
Life expectancy	Hrs	Up to 150 000 hours	
Inrush current	A	350 • I _R	
LT-APP		B25160C . . .	
Power	KVAr	5...66.2	
Voltage range	V	440...750 V*	
Frequency	Hz	50 Hz/ 60Hz	
Impregnation		Non PCB, synthetic oil	
Life expectancy	Hrs	Up to 150 000 hours	
Inrush current	A	300 • I _R	

*Other voltages on request.

PQS Key Components Overview

PF controllers					
BR6000					
	BR6000-R06	BR6000-R12	BR6000-T06	BR6000-T12	
Supply voltage	245 V AC (±20%; L-N)	245 V AC (±20%; L-N)	245 V AC (±20%; L-N)	245V AC (±20%; L-N)	
Measurement voltage range	30-525 V AC (L-N) or (L-L)	30-525 V AC (L-N) or (L-L)	30-300 V AC (L-N)	30-300 V AC (L-N)	
Measurement current	X/5 or X1/A selectable	X/5 or X1/A selectable	X/5 or X1/A selectable	X/5 or X1/A selectable	
Frequency	50/60 Hz	50/60 Hz	50/60 Hz	50/60 Hz	
BR5000					
	BR5000-R08	BR5000-R16	BR5000-T16		
Supply voltage	415V AC (-40% to +20%; L-L)	415V AC (-40% to +20%; L-L)	415V AC (-40% to +20%; L-L)		
Measurement voltage range	3Ph 3wire 415V AC (-40% to +20%)	3Ph 3wire 415V AC (-40% to +20%)	3Ph 3wire 415V AC (-40% to +20%)		
Measurement current	X/5 or X1/A selectable	X/5 or X1/A selectable	Only 5Amp CT secondary		
Frequency	45Hz to 62.5Hz	45Hz to 62.5Hz	45 Hz to 55 Hz		
BR4000-ER					
	BR4004	BR4006	BR4008		
Supply voltage	110 V AC – 550VAC	110 V AC – 550VAC	110 V AC – 550VAC		
Measurement voltage range	30 ... 550 V AC (L-L / L-N)	30 ... 550 V AC (L-L / L-N)	30 ... 550 V AC (L-L / L-N)		
Measurement current	x/5 and x/1 Ampere onsite programmable	x/5 and x/1 Ampere onsite programmable	x/5 and x/1 Ampere onsite programmable		
Frequency	45 and 70 Hz	45 and 70 Hz	45 and 70 Hz		
BR2100					
	BR2006	BR2008	BR2012		
Supply Voltage	110 V AC – 550VAC	110 V AC – 550VAC	110 V AC – 550VAC		
Measurement Voltage range	30...550 VAC	30...550 V AC	30...550 V AC		
Measurement current	x/5 and x/1 Ampere onsite programmable	x/5 and x/1 Ampere onsite programmable	x/5 and x/1 Ampere onsite programmable		
Frequency	40 and 70 Hz	40 and 70 Hz	40 and 70 Hz		
BR4000 S					
	BR4104	BR4106	BR4108		
Supply Voltage	80 V AC – 300 V (L-N)	110 V AC – 550 V (L-N)	110 V AC – 550 V (L-N)		
Measurement Voltage range	80...300 V AC (L-N)	80...300 V AC (L-N)	80...300 V AC (L-N)		
Measurement current	x/5 and x/1 Ampere onsite programmable	x/5 and x/1 Ampere onsite programmable	x/5 and x/1 Ampere onsite programmable		
Frequency	50 Hz	50 Hz	50 Hz		

PQS Key Components Overview

Switching devices and detuned filters			
Parameter	Capacitor contactors	Thyristor modules	Reactors - Antiresonance harmonic filter
	With Pre-closing resistor	Thyristor switch for dynamic PFC systems	For detuning application with high linearity
Voltage	230...690 V	TSM-LC: 3 × 440 V TSM-HV: 3 × 690 V	230...1000 V
Output range	12.5...100 KVA _r for B...J230 7...60 KVA _r for B...C240	TSM-LCN: 10...50 KVA _r TSM-HV: 50 KVA _r	5...100 KVA _r
Frequency	50/60 Hz	50/60 Hz	50 or 60 Hz
Detuning	Suitable for detuned and conventional systems	Suitable for detuned and conventional systems	Factor: 5.67%, 7%, 14%
Ordering code	B44066S...J230 for all PFC systems B44066S...C240 for all PFC systems	TSM-LCN: B44066T...R442 TSM-HV: B44066T...R690	B44066D...
			

Important Notes

The following applies to all products named in this publication:

1. Some parts of this publication contain statements about the suitability of our products for certain areas of application. These statements are based on our knowledge of typical requirements that are often placed on our products in the areas of application concerned. We nevertheless expressly point out that such statements cannot be regarded as binding statements about the suitability of our products for a particular customer application. As a rule, TDK is either unfamiliar with individual customer applications or less familiar with them than the customers themselves. For these reasons, it is always ultimately incumbent on the customer to check and decide whether TDK product with the properties described in the product specification is suitable for use in a particular customer application.
2. We also point out that in individual cases, a malfunction of electronic components or failure before the end of their usual service life cannot be completely ruled out in the current state of the art, even if they are operated as specified. In customer applications requiring a very high level of operational safety and especially in customer applications in which the malfunction or failure of an electronic component could endanger human life or health (e.g. in accident prevention or life-saving systems), it must therefore be ensured by means of suitable design of the customer application or other action taken by the customer (e.g. installation of protective circuitry or redundancy) that no injury or damage is sustained by third parties in the event of malfunction or failure of an electronic component.
3. The warnings, cautions and product-specific notes must be observed.
4. In order to satisfy certain technical requirements, some of the products described in this publication may contain substances subject to restrictions in certain jurisdictions (e.g. because they are classed as hazardous). Useful information on this will be found in our material data sheets on the internet <https://in.tdk-electronics.tdk.com>. Should you have any more detailed questions, please contact our sales offices.
5. We constantly strive to improve our products. Consequently, the products described in this publication may change from time to time. The same is true of the corresponding product specifications. Please check therefore to what extent product descriptions and specifications contained in this publication are still applicable before or when you place an order.

We also reserve the right to discontinue production and delivery of products. Consequently, we cannot guarantee that all products named in this publication will always be available.

The aforementioned does not apply in the case of individual agreements deviating from the foregoing for customer-specific products.
6. Unless otherwise agreed in individual contracts, all orders are subject to the current version of the "General Terms of Delivery for Products and Services in the Electrical Industry" published by the German Electrical and Electronics Industry Association (ZVEI).
7. The trade names EPCOS, Alu-X, CeraDiode, CeraLink, CeraPad, CeraPlas, CSMP, CSSP, CTVS, DeltaCap, DigiSiMic, DSSP, ExoCore, FilterCap, FormFit, LeaXield, MiniBlue, MiniCell, MKD, MKK, MotorCap, PCC, PhaseCap, PhaseCube, PhaseMod, PhiCap, PQSine, SIFERRIT, SIFI, SIKOREL, SilverCap, SIMDAD, SiMic, SIMID, SineFormer, SIOV, SIP5D, SIP5K, TAP, ThermoFuse, WindCap are trademarks registered or pending in Europe and in other countries.

PhaseCap Energy HD PFC Capacitors

Gas-impregnated • Dry type • Stacked winding • Wavy cut • Triple safety system

General

The series PhaseCap Energy represents a new generation of capacitors for power factor correction (PFC). On basis of the well proven MKK-technology, this follow-on development of the PhaseCap series offers some major enhancements. A service life expectation of up to 150000 hours, an increased inrush current capability of up to 400. I_R and reduced can dimensions make the PhaseCap Energy the ideal capacitor for industrial applications that call for high reliability.

PhaseCap Energy is available in two versions: Series B25674L is gas filled. These are equipped with self-healing properties and three phase overpressure disconnecter. A voltage range from 415 to 690 V, outputs of 5.0 to 33.1 KVAR and four different terminal types allow the selection of the customized capacitor type.



Applications

- Automatic PFC equipment, capacitor banks
- Individual fixed PFC (e.g. motors, transformers, lighting)
- Group fixed PFC
- Detuned capacitor banks
- Filter applications
- Dynamic PFC

Features

- Compact design in cylindrical aluminum can with stud
- Stacked winding
- MKK-technology with wavy cut and heavy edge
- Voltage range 415 V ... 800 V
- Output range 5.0 ... 33.1 KVAR

Electrical

- Long life expectancy upto 150000 Hours at temp class -40/D°C
- High pulse current withstand capability
- High long term stability

Mechanical and maintenance

- Reduced mounting costs
- Mounting position upright/ horizontal
- Maintenance-free
- Highest packing density thanks to compact dimensions

Safety

- Self-healing
- Overpressure disconnecter
- Shock hazard protected terminals
- Longterm approved
- Ceramic discharge resistor pre-mounted

Environmental

- Dry design, inert gas
- No oil leakage

PhaseCap Energy HD PFC Capacitors

Gas-impregnated • Dry type • Stacked winding • Wavy cut • Triple safety system

Technical data : PhaseCap Energy HD PFC capacitors

Series Type	B25674L Upto 690V; B25667C above 690V*
Power-KVAr	5...33.1KVAr
Rated voltage-V (AC)	415...800 V**
Frequency	50 Hz
Transient peak current maximum permissible	400 • I _R
Maximum permissible temperature category	-40/60; max. temp. +60 °C; max. mean 24 h = +45 °C; max. mean 1 year = +35 °C; lowest temperature = -40 °C
Losses (without discharge resistors)	0.45W/KVAr
Maximum Permissible voltage	V _R + 10%(up to 8 h daily)/ V _R + 15% (up to 30 min daily)*** V _R + 20%(up to 5 min daily)/ V _R + 30% (up to 1 min daily)***
Maximum Permissible current	up to 1.6 ... 1.8 · I _R including combined effects of harmonics, overvoltages and capacitance tolerance ****
Safety	Three-phase overpressure disconnecter, self-healing, maximum allowed fault current 10 000 A in accordance with UL 810 standard,
Impregnation	Gas-impregnated, dry type, Non-PCB
Life expectancy	up to 150 000 h (temp. class -40/D)
Cooling	Natural or forced
Case shape/finish	Extruded round aluminium can with stud
Terminal	Optimized capacitor safety terminals
Mounting and grounding	Threaded stud at bottom of can (max. torque for M12=10Nm)
Enclosure	IP 20, indoor mounting (optionally with terminal cap for IP54)
Discharge resistor	Provided with discharge resistor
Connection	Delta
Casing of capacitor cell	Extruded round aluminium can with stud
Dielectric	Polypropylene film (metallised)
No. of switching per annum	Max. 12500 switching
Reference standard	IEC60831-1/2 and IS13340

* The above specifications are for B25674L series; for specifications of B25667C series, please check with our nearest sales office.

** Other voltages available on request.

*** V_R rated voltage.

**** I_R: RMS line current that occurs at rated sinusoidal voltage and rated frequency, excluding transients.

Note: for capacitors with different features/parameters than above, please check with our nearest sales office.

PhaseCap Energy HD PFC Capacitors

Gas-impregnated • Dry type • Stacked winding • Wavy cut • Triple safety system

PhaseCap Energy HD PFC capacitors - 3 Phase									
Rating KVA _r	Voltage V (AC)	Material code	I _r A	C _N μF	d x h mm	Packing units		MOQ	Approx weight Kg
PhaseCap Energy HD - 415 V(AC) 3PH, 50Hz (Series B25674L)									
5	415	B25674L4052J 15	7	3 x 30.8	75x164	1	1		0.7
6.3	415	B25674L4062J315	8.8	3 x 38.8	75x164	1	1		0.7
7.5	415	B25674L4072J515	10.4	3 x 46.2	75x200	1	1		0.8
8.3	415	B25674L4082J315	11.5	3 x 51.1	75x200	1	1		0.8
10.4	415	B25674L4102J415	14.5	3 x 64.1	75x200	1	1		0.8
15	415	B25674L4152J 15	20.9	3 x 92.4	85x200	1	1		1.1
20	415	B25674L4202J 15	27.8	3 x 123.2	100x207	1	1		1.6
25	415	B25674L4252J 15	34.8	3 x 154.0	116x192	1	1		1.9
28.1	415	B25674L4282J115	39.1	3 x 173.1	116x207	1	1		2.1
30	415	B25674L4302J 15	41.7	3 x 184.8	116x207	1	1		2.1
33	415	B25674L4332J 15	45.9	3 x 203.3	116x224	1	1		2.3
PhaseCap Energy HD - 440 V(AC) 3PH, 50Hz (Series B25674L)									
5	440	B25674L4052J 40	6.6	3 x 27.4	75x164	1	4		0.7
6	440	B25674L4062J 40	7.9	3 x 32.9	75x164	1	4		0.7
6.3	440	B25674L4062J340	8.3	3 x 34.5	75x164	1	4		0.7
7	440	B25674L4072J 40	9.2	3 x 38.4	75x200	1	4		0.8
7.5	440	B25674L4072J540	9.8	3 x 41.1	75x200	1	4		0.8
8	440	B25674L4082J 40	10.5	3 x 43.8	75x200	1	4		0.8
10	440	B25674L4102J 40	13.1	3 x 54.8	75x200	1	4		0.8
12.5	440	B25674L4122J540	16.4	3 x 68.5	85x200	1	4		1.1
14.2	440	B25674L4142J240	18.6	3 x 77.8	85x200	1	4		1.1
15	440	B25674L4152J 40	19.7	3 x 82.2	85x218	1	4		1.2
18.8	440	B25674L4182J840	24.7	3 x 103.0	100x207	1	4		1.6
20	440	B25674L4202J 40	26.2	3 x 109.6	100x207	1	4		1.6
25	440	B25674L4252J 40	32.8	3 x 137.0	116x192	1	4		1.9
28.1	440	B25674L4282J140	36.9	3 x 154.0	116x207	1	4		2.1
33.1	440	B25674L4332J140	43.4	3 x 181.4	116x224	1	4		2.3
PhaseCap Energy HD - 480 V(AC) 3PH, 50Hz (Series B25674L)									
5	480	B25674L4052J 80	6	3 x 23.0	75x164	1	4		0.7
6.3	480	B25674L4062J380	7.6	3 x 29.0	75x164	1	4		0.7
7.5	480	B25674L4072J580	9	3 x 34.5	75x200	1	4		0.8
8.3	480	B25674L4082J380	10	3 x 38.2	75x200	1	4		0.8
10.4	480	B25674L4102J480	12.5	3 x 47.9	75x200	1	4		0.8
11	480	B25674L4112J 80	13.2	3 x 50.7	85x200	1	4		1.1
12.5	480	B25674L4122J580	15	3 x 57.6	85x200	1	4		1.1
13.8	480	B25674L4132J880	16.6	3 x 63.5	85x200	1	4		1.1
15	480	B25674L4152J 80	18	3 x 69.1	100x207	1	4		1.6
16.7	480	B25674L4162J780	20.1	3 x 76.9	100x207	1	4		1.6
20	480	B25674L4202J 80	24.1	3 x 92.1	100x207	1	4		1.6
20.8	480	B25674L4202J880	25	3 x 95.8	116x207	1	4		2.1
22	480	B25674L4222J 80	26.5	3 x 101.3	116x207	1	4		2.1
25	480	B25674L4252J 80	30.1	3 x 115.1	116x192	1	4		1.9
28.1	480	B25674L4282J180	33.8	3 x 129.4	116x207	1	4		2.1
33	480	B25674L4332J 80	39.7	3 x 152.0	116x224	1	4		2.3
PhaseCap Energy HD - 525 V(AC) 3PH, 50Hz (Series B25674L)									
5	525	B25674L5052J 25	5.5	3 x 19.2	75x164	1	4		0.7
6.3	525	B25674L5062J325	6.9	3 x 24.2	75x164	1	4		0.7
7.5	525	B25674L5072J525	8.2	3 x 28.9	75x185	1	4		0.8
8.3	525	B25674L5082J325	9.1	3 x 31.9	75x200	1	4		0.8
10.4	525	B25674L5102J425	11.4	3 x 40.0	85x185	1	4		1.0
12.5	525	B25674L5122J525	13.7	3 x 48.1	85x200	1	4		1.1
13.2	525	B25674L5132J225	14.6	3 x 50.8	85x200	1	4		1.1
15	525	B25674L5152J 25	16.5	3 x 57.7	85x218	1	4		1.2
16.7	525	B25674L5162J725	18.4	3 x 64.3	100x207	1	4		1.6
20	525	B25674L5202J 25	22	3 x 77.0	100x224	1	4		1.7
20.8	525	B25674L5202J825	22.9	3 x 80.1	100x224	1	4		1.7
25	525	B25674L5252J 25	27.5	3 x 96.2	116x207	1	4		2.1
26.5	525	B25674L5262J525	29.1	3 x 102.0	116x207	1	4		2.1
33.1	525	B25674L5332J125	36.4	3 x 127.4	136x192	1	4		2.7

PhaseCap Energy HD PFC Capacitors

Gas-impregnated • Dry type • Stacked winding • Wavy cut • Triple safety system

PhaseCap Energy HD PFC capacitors - 3 Phase								
Rating KVA _r	Voltage V (AC)	Material code	I _r A	C _N μF	d x h mm	Packing units	MOQ	Approx weight Kg
PhaseCap Energy HD - 690 V(AC) 3PH, 50Hz (Series B25674L)								
5.3	690	B25674L6052J390	4.4	3 x 11.8	75x185	1	1	0.8
10.4	690	B25674L6102J490	8.7	3 x 23.2	75x200	1	1	0.8
12.5	690	B25674L6122J590	10.5	3 x 27.9	85x200	1	1	1.1
14.6	690	B25674L6142J690	12.2	3 x 32.5	100x207	1	1	1.6
20	690	B25674L6202J 90	16.7	3 x 44.6	100x207	1	1	1.6
25	690	B25674L6252J 90	20.9	3 x 55.7	116x192	1	4	1.9
28	690	B25674L6282J 90	23.4	3 x 62.4	116x207	1	1	2.1
PhaseCap Energy HD - 800 V(AC) 3PH, 50Hz (Series B25667)								
5	800	B25667C7246A375	3.6	3 x 8	116 x 164	6	6	1.2
7.5	800	B25667C7376A375	5.4	3 x 12.4	116 x 164	6	6	1.2
10	800	B25667C7496A375	7.2	3 x 17	116 x 164	6	6	1.3
12.5	800	B25667C7626A375	9	3 x 21	116 x 164	6	6	1.4
15	800	B25667C7746A375	11	3 x 25	116 x 164	6	6	1.5
20	800	B25667C7996A375	14.5	3 x 33	136 x 200	4	4	2.0
25	800	B25667C7127A375	18	3 x 41	136 x 200	4	4	2.3
28	800	B25667C7137A375	20	3 x 46	136 x 200	4	4	2.4

Other voltages available on request.

Packing units for capacitors equal minimum order quantity.

Orders will be rounded up to packing unit or multiple thereof.

PhaseCap Energy HD PFC Capacitors

Gas-impregnated • Dry type • Stacked winding • Wavy cut • Triple safety system

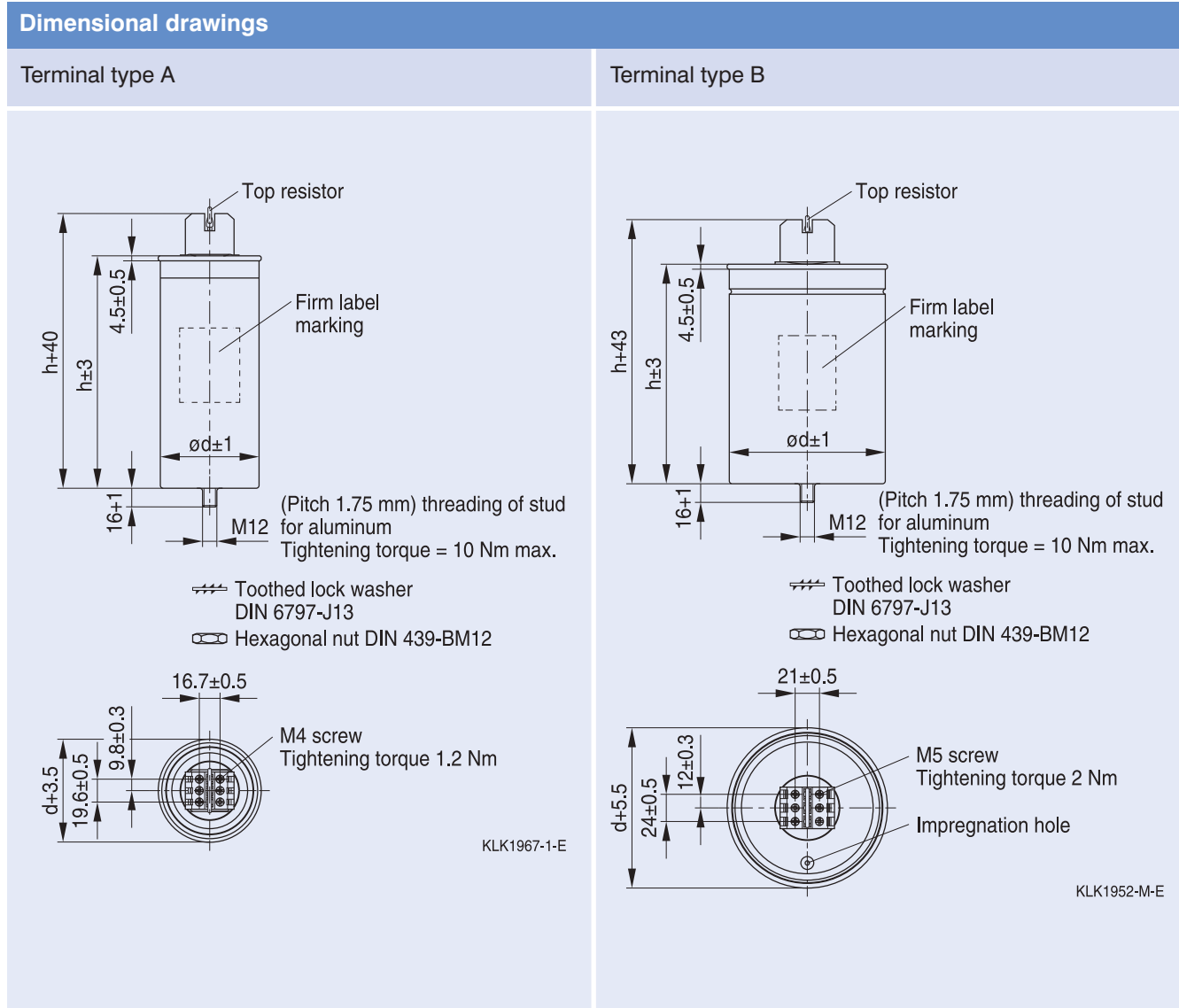

PhaseCap Energy HD PFC Capacitors

Gas-impregnated • Dry type • Stacked winding • Wavy cut • Triple safety system

Dimensional drawings

Terminal type C

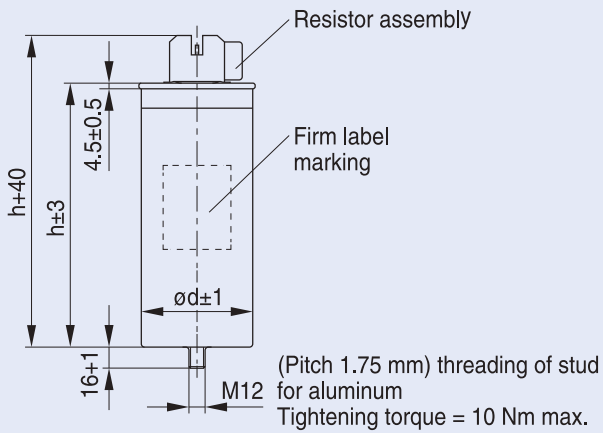

- Toothed lock washer
DIN 6797-J13
- Hexagonal nut DIN 439-BM12

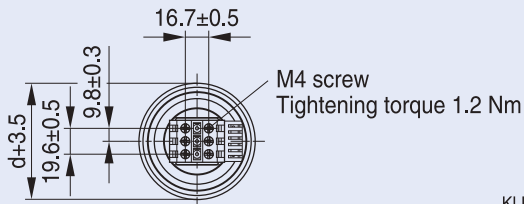

KLK1962-U-E

Terminal type D

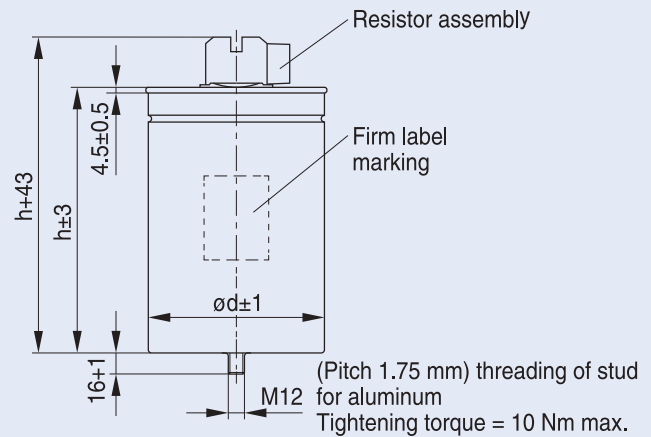

- Toothed lock washer
DIN 6797-J13
- Hexagonal nut DIN 439-BM12

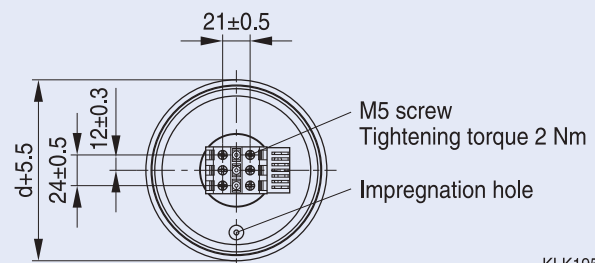

KLK1957-T-E

PhaseCap Super Heavy Duty PFC Capacitors

Semi-dry biodegradable resin • Stacked winding • Wavy cut • Triple safety system

General

The new PhaseCap Super Heavy Duty (SHD) PFC capacitor is based on the MKK technology known for many years from the successful PhaseCap series with its unique stacked windings. Based on years of experience in PFC and millions of sold capacitors, TDK presents the next step in PFC capacitor evolution.

Using polypropylene as dielectric and semi-dry biodegradable resin as impregnation agent, the PhaseCap Super Heavy Duty (SHD)

offers higher inrush current capability up to $500 I_R$ and over current capability up to $1.6...2.0 \cdot I_R$ even compared to PhaseCap. With an output of up to 37.1 KVAR at very small height it meets the dimensional requirements of panel builders. Its new enhanced terminals permit the connection of a broader variety of cables and cable sizes. Depending on the operating conditions PhaseCap SHD provides a life expectancy of up to 200 000 hours, more than any other capacitor in the EPCOS PFC capacitor portfolio.



Applications

- Automatic PFC equipment, capacitor banks
- Individual fixed PFC (e.g. motors, transformers, lighting)
- Group fixed PFC
- Detuned capacitor banks
- Filter applications
- Dynamic PFC

Features

- Compact design in cylindrical aluminum can with stud
- Concentric winding
- MKK-technology with wavy cut and heavy edge
- Voltage range: 415 ... 1000 V
- Output range: 1.0 ... 37.1 KVAR

Electrical features

- Very high life expectancy
High inrush current capability (up to $500 \cdot I_R$)
- High overcurrent capability (up to $2.0 \cdot I_R$)

Mechanical and maintenance

- Reduced mounting costs
- Maintenance-free
- Compact dimensions
- Mounting position upright

Safety

- Self healing
- Overpressure disconnecter
- Shock hazard protected terminals
- Pre-mounted ceramic discharge resistor

PhaseCap Super Heavy Duty PFC Capacitors

Semi-dry biodegradable resin • Stacked winding • Wavy cut • Triple safety system

Technical data : PhaseCap Super Heavy Duty PFC capacitors	
Series type	B25675L Upto 690V; B25673L above 690V*
Power-KVAr	1 ... 37.1 KVAr
Rated voltage-V (AC)	415...1000 V**
Frequency	50 Hz
Transient peak current maximum permissible	$500 \cdot I_R$
Maximum permissible temperature category	-40/60; max. temp. +60 °C; max. mean 24 h = +45 °C max. mean 1 year = +35 °C; lowest temperature = -40 °C
Losses (without discharge resistors)	$\leq 0.45W/KVAr$
Maximum permissible voltage	$V_R + 10\%$ (up to 8 h daily)/ $V_R + 15\%$ (up to 30 min daily)*** $V_R + 20\%$ (up to 5 min daily)/ $V_R + 30\%$ (up to 1 min daily)***
Maximum permissible current	up to 1.6 ... 2.0 · I_R including combined effects of harmonics, overvoltages and capacitance tolerance ****
Safety	Self-healing, overpressure disconnecter
Impregnation	Non-PCB, semi-dry biodegradable resin
Life expectancy	up to 200 000 h (temp. class -40/D); up to 180 000 h (temp. class -40/60)
Cooling	Natural or forced
Case shape/finish	Extruded round aluminium can with stud
Terminal	Optimized capacitor safety terminals
Mounting and grounding	Threaded stud at bottom of can (max. torque for M12=Nm)
Enclosure	IP 20, indoor mounting (optionally with terminal cap for IP54)
Discharge resistor	Provided with discharge resistor
Connection	Delta
Casing of capacitor cell	Extruded round aluminium can with stud
Dielectric	Polypropylene film (metallised)
No. of switching per annum	Max. 15000 switching
Reference standard	IEC60831-1/2 and IS13340

* The above specifications are for B25675L series, for specifications of B25673L series, please check with our nearest sales office.

** Other voltages available on request.

*** V_R rated voltage.

**** I_R : RMS line current that occurs at rated sinusoidal voltage and rated frequency, excluding transients.

Note : for capacitors with different features/parameters than above, please check with our nearest sales office.

PhaseCap Super Heavy Duty PFC Capacitors

Semi-dry biodegradable resin • Stacked winding • Wavy cut • Triple safety system

PhaseCap Super Heavy Duty PFC capacitors								
Rating KVA _r	Voltage V (AC)	Material code	I _r A	C _N μF	d x h mm	Packing units	MOQ	Approx. weight Kg
PhaseCap SHD - 415 V(AC) 3PH, 50Hz (Series B25675L)								
5	415	B25675L4052J 15	7	3 x 30.8	75x164	1	4	0.9
6.3	415	B25675L4062J315	8.8	3 x 38.8	75x164	1	1	0.9
7.5	415	B25675L4072J515	10.4	3 x 46.2	75x200	1	1	1.1
10.4	415	B25675L4102J415	14.5	3 x 64.1	75x200	1	1	1.1
12.5	415	B25675L4122J515	17.4	3 x 77.0	85x200	1	1	1.3
15	415	B25675L4152J 15	20.9	3 x 92.4	85x200	1	1	1.3
20	415	B25675L4202J 15	27.8	3 x 123.2	100x207	1	1	1.9
25	415	B25675L4252J 15	34.8	3 x 154.0	116x192	1	1	2.4
28.1	415	B25675L4282J115	39.1	3 x 173.1	116x207	1	1	2.6
30	415	B25675L4302J 15	41.7	3 x 184.8	116x207	1	1	2.6
33	415	B25675L4332J 15	45.9	3 x 203.3	116x224	1	1	2.8
PhaseCap SHD - 440 V(AC) 3PH, 50Hz (Series B25675L)								
1	440	B25675L4012J 40	1.3	3 x 5.5	53x117	1	1	0.3
2	440	B25675L4022J 40	2.6	3 x 11.0	53x129	1	1	0.4
3	440	B25675L4032J 40	3.9	3 x 16.4	53x129	1	1	0.4
4	440	B25675L4042J 40	5.2	3 x 21.9	63.5x152	1	1	0.5
5	440	B25675L4061J 40	6.6	3 X 27.4	63.5 X 152	1	1	0.5
7.5	440	B25675L4072J540	9.8	3 x 41.1	75x200	1	1	1.1
10	440	B25675L4102J 40	13.1	3 x 54.8	75x200	1	1	1.1
12.5	440	B25675L4122J540	16.4	3 x 68.5	85x200	1	1	1.3
15	440	B25675L4152J 40	19.7	3 x 82.2	85x218	1	1	1.5
20	440	B25675L4202J 40	26.2	3 x 109.6	100x207	1	1	1.9
25	440	B25675L4252J 40	32.8	3 x 137.0	116x192	1	1	2.4
28.1	440	B25675L4282J140	36.9	3 x 154.0	116x207	1	1	2.6
30	440	B25675L4302J 40	39.4	3 x 164.4	125x192	1	1	2.8
33.1	440	B25675L4332J140	43.4	3 x 181.4	116x224	1	1	2.8
PhaseCap SHD - 480 V(AC) 3Pz, 50Hz (Series B25675L)								
5	480	B25675L4052J 80	6	3 x 23.0	75x164	1	1	0.9
6.3	480	B25675L4062J380	7.6	3 x 29.0	75x164	1	1	0.9
8.3	480	B25675L4082J380	10	3 x 38.2	75x200	1	1	1.1
10.4	480	B25675L4102J480	12.5	3 x 47.9	75x200	1	1	1.1
11	480	B25675L4112J 80	13.2	3 x 50.7	85x200	1	1	1.3
12.5	480	B25675L4122J580	15	3 x 57.6	85x200	1	1	1.3
13.8	480	B25675L4132J880	16.6	3 x 63.5	85x200	1	1	1.3
15	480	B25675L4152J 80	18	3 x 69.1	100x207	1	1	1.9
16.7	480	B25675L4162J780	20.1	3 x 76.9	100x207	1	1	1.9
18.7	480	B25675L4182J780	22.5	3 x 86.1	100x207	1	1	1.9
20	480	B25675L4202J 80	24.1	3 x 92.1	100x207	1	1	1.9
20.8	480	B25675L4202J880	25	3 x 95.8	116x207	1	1	2.6
22	480	B25675L4222J 80	26.5	3 x 101.3	116x207	1	1	2.6
25	480	B25675L4252J 80	30.1	3 x 115.1	116x192	1	1	2.4
28.1	480	B25675L4282J180	33.8	3 x 129.4	116x207	1	1	2.6
31	480	B25675L4312J 80	37.3	3 x 142.7	116x224	1	1	2.8
33	480	B25675L4332J 80	39.7	3 x 152.0	116x224	1	1	2.8
PhaseCap SHD - 525 V(AC) 3Pz, 50Hz (Series B25675L)								
5	525	B25675L5052J 25	5.5	3 x 19.2	75x164	1	1	0.9
6.3	525	B25675L5062J325	6.9	3 x 24.2	75x164	1	1	0.9
8.3	525	B25675L5082J325	9.1	3 x 31.9	75x200	1	1	1.1
10.4	525	B25675L5102J425	11.4	3 x 40.0	85x185	1	1	1.2
12.5	525	B25675L5122J525	13.7	3 x 48.1	85x200	1	1	1.3
13.2	525	B25675L5132J225	14.6	3 x 50.8	85x200	1	1	1.3
15	525	B25675L5152J 25	16.5	3 x 57.7	85x218	1	1	1.5
16.7	525	B25675L5162J725	18.4	3 x 64.3	100x207	1	1	1.9
20	525	B25675L5202J 25	22	3 x 77.0	100x224	1	1	2.1
25	525	B25675L5252J 25	27.5	3 x 96.2	116x207	1	1	2.6
26.5	525	B25675L5262J525	29.1	3 x 102.0	116x207	1	1	2.6
30	525	B25675L5302J 25	33	3 x 115.5	125 x 207	1	1	3.0
33.1	525	B25675L5332J125	36.4	3 x 127.4	136x192	1	1	3.3
37.1	525	B25673S5372L120	40.8	3 X 142.9	136 X 224	1	1	3.6

PhaseCap Super Heavy Duty PFC Capacitors

Semi-dry biodegradable resin • Stacked winding • Wavy cut • Triple safety system

PhaseCap Super Heavy Duty PFC capacitors - 3 Phase								
Rating KVAR	Voltage V (AC)	Material code	I _R A	C _N μF	d x h mm	Packing units	MOQ	Approx. weight Kg
PhaseCap SHD - 690 V(AC) 3Pz, 50Hz (Series B25675L)								
5.3	690	B25675L6052J390	4.4	3 x 11.8	75x185	1	1	1.0
6.9	690	B25675L6062J990	5.8	3 x 15.4	75x200	1	1	1.1
10.4	690	B25675L6102J490	8.7	3 x 23.2	75x200	1	1	1.1
12.5	690	B25675L6122J590	10.5	3 x 27.9	85x200	1	1	1.3
14.6	690	B25675L6142J690	12.2	3 x 32.5	100x207	1	1	1.9
20	690	B25675L6202J 90	16.7	3 x 44.6	100x207	1	1	1.9
25	690	B25675L6252J 90	20.9	3 x 55.7	116x192	1	1	2.4
28	690	B25675L6282J 90	23.4	3 x 62.4	116x207	1	1	2.6
PhaseCap SHD - 800 V(AC) 3PH, 50Hz (Series B25673)								
5	800	B25673L8052A000	3.6	3 x 8.3	116 x 164	1	1	2.1
7.5	800	B25673L8072A500	5.4	3 x 12.4	116 x 164	1	1	2.1
10.0	800	B25673L8102A000	7.2	3 x 16.6	116 x 164	1	1	2.1
12.5	800	B25673L8122A500	9	3 x 20.7	116 x 164	1	1	2.1
15	800	B25673L8152A000	10.8	3 x 24.9	116 x 164	1	1	2.1
20	800	B25673L8202A000	15	3 x 33.2	136 x 200	1	1	3.2
25	800	B25673L8252A000	18	3 x 41.4	136 x 200	1	1	3.2
28	800	B25673L8252A000	20.2	3 x 46.4	136 x 200	1	1	3.2
PhaseCap SHD - 900 V(AC) 3PH, 50Hz (Series B25673)								
10.4	900	B25673L9102A400	6.7	3 x 13.6	116 x 164	1	1	2.0
12.5	900	B25673L9122A500	8	3 x 16.4	116 x 164	1	1	2.0
15	900	B25673L9152A000	9.6	3 x 19.7	116 x 200	1	1	2.4
20	900	B25673L9202A000	12.8	3 x 26.2	136 x 200	1	1	3.1
25	900	B25673L9252A000	16	3 x 32.7	136 x 200	1	1	3.1
PhaseCap SHD - 1000 V(AC) 3PH, 50Hz (Series B25673)								
10.4	1000	B25673L0102A400	6	3 x 11.0	116 x 164	1	1	2.0
12.5	1000	B25673L0122A500	7.2	3 x 13.3	116 x 164	1	1	2.0
15	1000	B25673L0152A000	8.7	3 x 15.9	116 x 200	1	1	2.4
20	1000	B25673L0202A000	11.6	3 x 21.2	136 x 200	1	1	3.1
25	1000	B25673L0252A000	14.4	3 x 26.5	136 x 200	1	1	3.1

Packing units for capacitors equal minimum order quantity.
Orders will be rounded up to packing unit or multiple thereof.

PhaseCap SHD PFC Capacitors

Semi-dry biodegradable resin • Stacked winding • Wavy cut • Triple safety system

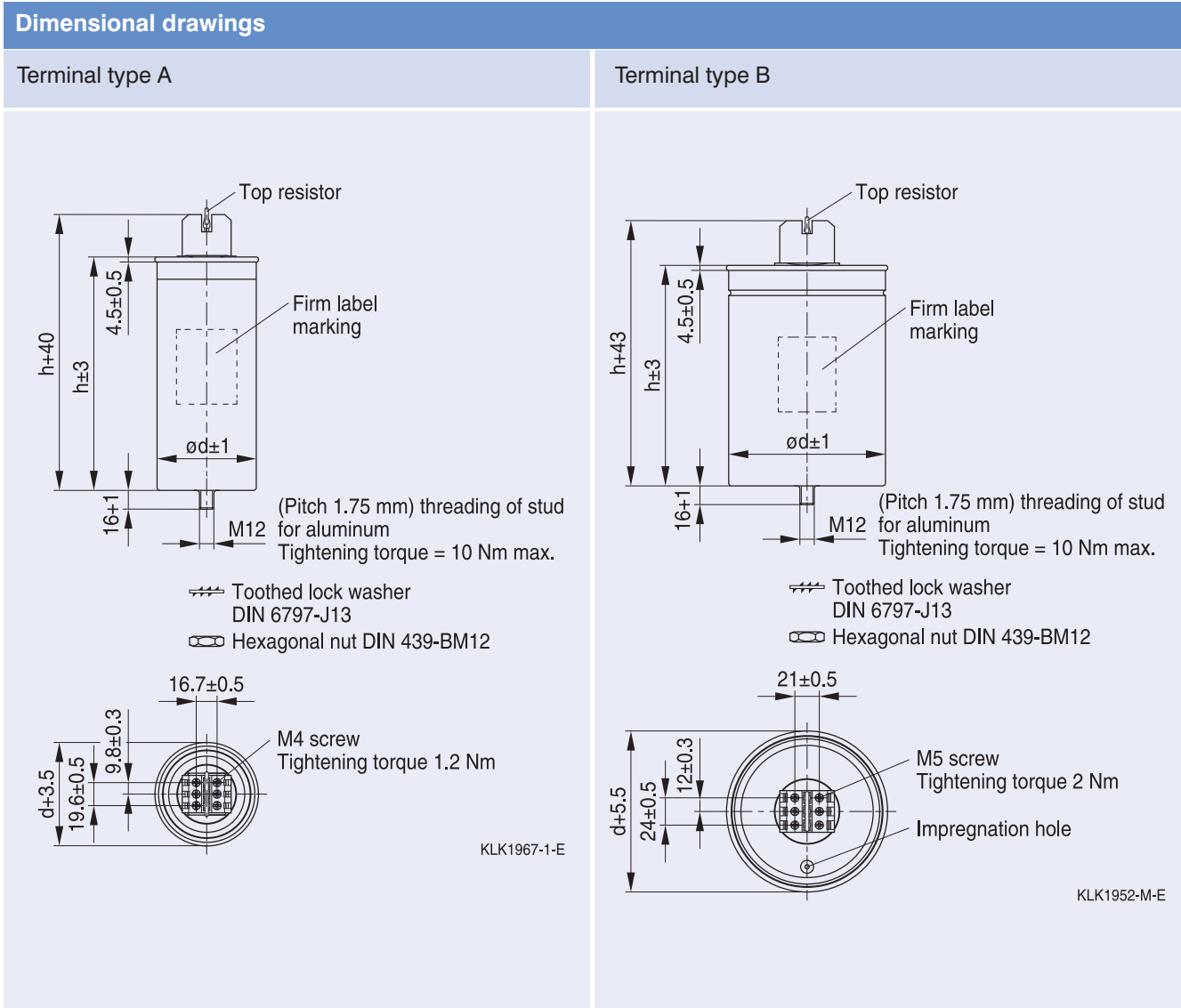

PhaseCap SHD PFC Capacitors

Semi-dry biodegradable resin • Stacked winding • Wavy cut • Triple safety system

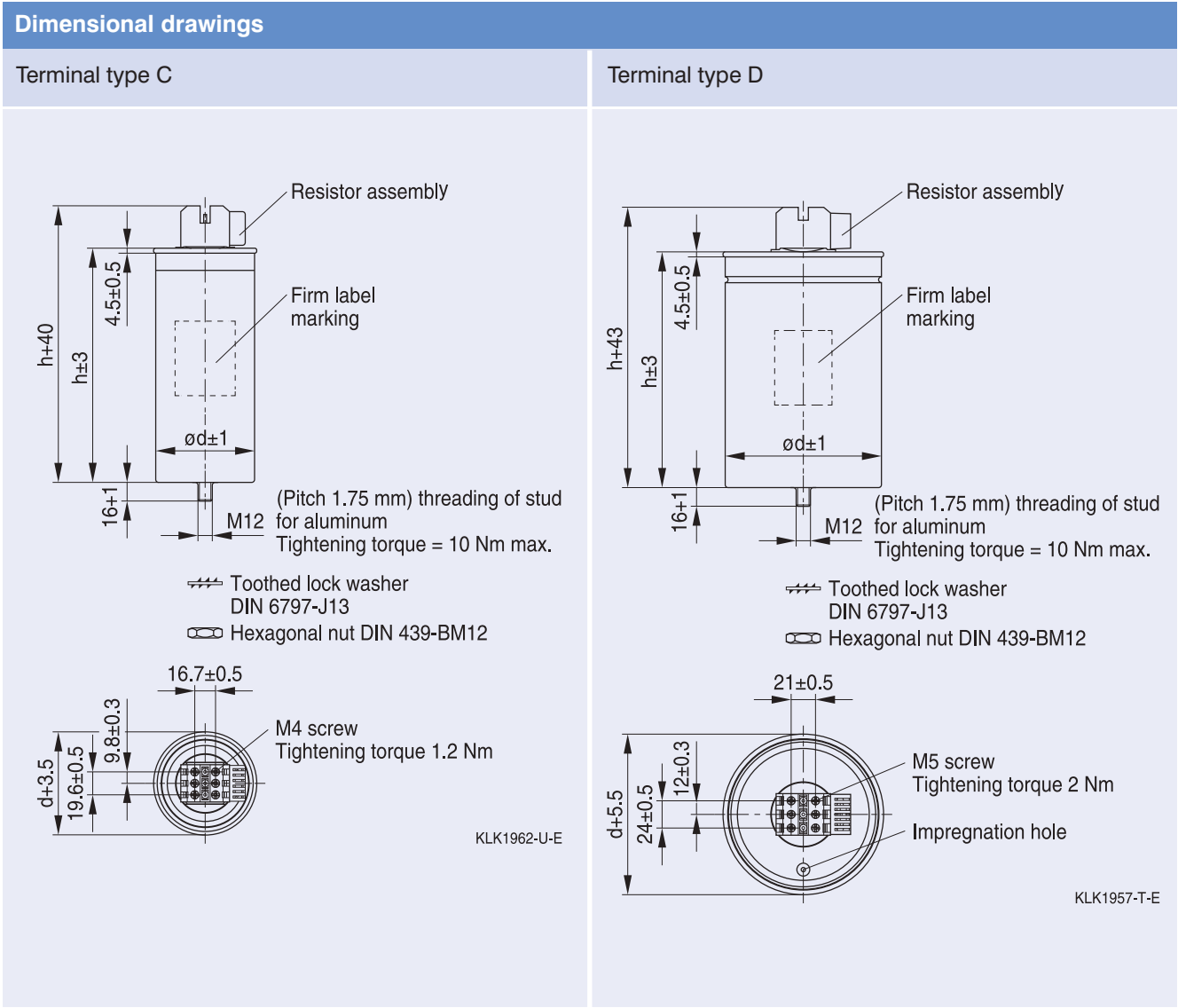

PhiCap PFC Capacitors

Semi-dry biodegradable resin • Stacked winding • Dual safety system

General

PhiCap capacitors are a tried and tested series of MKP (metalized polypropylene) capacitors from TDK which have been used for PFC applications for more than 20 years.

The power range varies from 0.5 to 33.1 KVAR and 0.7 to 6.0 KVAR per single capacitor can, depending on a three-phase or single-phase capacitor design.

The PhiCap capacitor is especially intended for power factor correction in industrial applications.

The capacitors are manufactured using metalized polypropylene film as the dielectric and housed in a cylindrical aluminum case.

- Normal Duty (ND) for linear inductive loads.



Applications

- Power Factor Correction (PFC), automatic capacitor banks
- Fixed PFC applications, e.g. motor compensation
- Detuned PFC systems
- Dynamic PFC systems

Features

- Compact design in cylindrical aluminum can with stud
- Stacked winding
- MKP technology
- Voltage range 230 ... 525 V
- Output range 0.5... 33.1 KVAR

Electrical

- Up to 33.1 KVAR per case for three phase applications
- Up to 6 KVAR per case for single phase applications
- Long life expectancy of up to 100 000 hours
- High pulse current withstand capability (up to $200 \cdot I_R$)

Mechanical and maintenance

- Reduced mounting costs, easy installation and connection
- Mounting position upright
- Low weight and compact volume
- Maintenance-free

Safety

- Self-healing
- Overpressure disconnecter

PhiCap PFC Capacitors

Semi-dry biodegradable resin • Stacked winding • Dual safety system

Technical data : PhiCap PFC capacitors	
PhiCap-ND	
Series type	B32343F (plastic top up to 6.3 KVAR) B32344F (metal top- 6.3 KVAR and onwards)
Power-KVAR	.5 to 33.1 KVAR
Rated voltage-V (AC)	230...525 V*
Frequency	50 Hz
Transient peak current maximum permissible	$200 \cdot I_R$
Maximum permissible temperature category	-25/D
Losses (without discharge resistor)	0.5 W/KVAR
Maximum permissible voltage	$V_R + 10\%$ (up to 8 h daily)/ $V_R + 15\%$ (up to 30 min daily)** $V_R + 20\%$ (up to 5 min daily)/ $V_R + 30\%$ (up to 1 min daily)**
Maximum permissible current	1.3 to $1.5 \cdot I_R$ ***
Safety	Self-healing, overpressure disconnecter
Impregnation	Non-PCB, semi-dry biodegradable resin
Life expectancy	Up to 100 000 hours
Cooling	Natural or forced
Case shape/finish	Extruded round aluminium can with stud
Terminal	6.3 mm fast-on terminals for plastic top -0.5 to 6.3 KVAR Screw terminal for metal top (6.3 KVAR and above)
Mounting and grounding	Threaded stud at bottom of can (max. torque 4 Nm for M8 and 10Nm for M12)
Enclosure	IP 00, indoor mounting (optionally with terminal cap for IP54)
Discharge resistor	Provided with discharge resistor
Connection	Delta
Casing of capacitor cell	Extruded round aluminium can with stud
Dielectric	Polypropylene film (metallised)
No. of switching per annum	Max. 5000 switching
Reference standard	IS : 13340

* Other voltages available on request

** V_R rated voltage

*** I_R : RMS line current that occurs at rated sinusoidal voltage and rated frequency, excluding transients.

Note : for capacitors with different features/parameters than above, please check with our nearest sales office

PhiCap PFC Capacitors

Semi-dry biodegradable resin • Stacked winding • Dual safety system

PhiCap Normal Duty (ND) capacitors - 3 Phase								
Rating KVAR	Voltage V (AC)	Material code	I _r A	C _N μF	d x h mm	Packing units	MOQ	Approx. weight Kg
PhiCap Normal Duty - 415 V(AC) 3PH, 50Hz (Series B32343 and B32344)								
1	415	B32343L4012A 10	1.4	3 x 6.5	53 x 117	12	12	0.3
1.5	415	B32343L4022A5 10	2.0	3 x 9.5	53 x 117	12	12	0.3
2	415	B32343L4022A 10	2.7	3 x 12.5	53 x 117	12	12	0.4
2.5	415	B32343F4022A 510	3.5	3 x 15.4	53 x 117	12	12	0.32
3	415	B32343F4032A 10	4.2	3 x 18.5	53 x 129	12	12	0.36
4	415	B32343F4042A 10	5.6	3 x 24.6	53 x 152	12	12	0.42
5	415	B32343F4052A 10	7.0	3 x 30.8	63.5 x 129	12	12	0.51
6.3	415	B32343F4062A3 10	8.8	3 x 38.8	63.5 x 152	12	12	0.6
7.5	415	B32344F4072A5 10	10.4	3 x 46.2	78.4 x 164	6	6	0.8
8.3	415	B32344F4082A3 10	11.5	3 x 51.1	78.4 x 164	6	6	0.8
9	415	B32344F4092A 10	12.5	3 x 55.4	78.4 x 164	6	6	0.8
10	415	B32344F4102A 10	13.9	3 x 61.6	78.4 x 197	6	6	0.96
12.5	415	B32344F4122A5 10	17.4	3 x 77.0	78.4 x 197	6	6	0.96
15	415	B32344B4152A5 10	20.8	3 x 92.5	85 x 270	1	4	1.8
20	415	B32344B41202A10	27.8	3 x 123.5	85 x 345	4	4	1.8
25	415	B32344B41252A 10	34.7	3 x 154	85 X 345	4	4	2.0
PhiCap Normal Duty - 440 V(AC) 3PH, 50Hz (Series B32343 & B32344)								
1	440	B32343L4012 A 40	1.3	3 x 5.5	53 x 117	12	12	0.3
1.5	440	B32343L4012 A540	1.9	3 x 8.5	53 x 117	12	12	0.3
2	440	B32343L4021 A540	2.8	3 x 11.5	53 x 117	12	12	0.4
2.5	440	B32343F4022A 540	3.3	3 x 13.7	53 x 117	12	12	0.32
3	440	B32343F4032A 40	3.9	3 x 16.4	53 x 117	12	12	0.32
4	440	B32343F4042A 40	5.2	3 x 21.9	53 x 129	12	12	0.36
5	440	B32343F4052A 40	6.6	3 x 27.4	53 x 152	12	12	0.42
5.6	440	B32343F4052A 640	7.3	3 x 30.7	63.5 x 152	12	12	0.6
6	440	B32343F4062A 40	7.9	3 x 32.9	63.5 x 152	12	12	0.6
7	440	B32344F4072A 40	9.2	3 x 38.4	78.4 x 164	6	6	0.8
7.5	440	B32344F4072 A 540	9.8	3 x 41.1	78.4 x 164	6	6	0.8
8.3	440	B32344F4082A 340	10.9	3 x 45.5	78.4 x 164	6	6	0.8
9	440	B32344F4092A 40	11.8	3 x 49.3	78.4 x 164	6	6	0.8
10	440	B32344F4102A 40	13.1	3 x 54.8	78.4 x 197	6	6	0.8
12.5	440	B32344F4122A 540	16.4	3 x 68.5	78.4 x 197	6	6	0.96
14	440	B32344B4142 A 40	18.3	3 x 76.4	85 x 270	1	4	1.0
15	440	B32344B4152 A 40	19.6	3 x 82.5	85 x 270	1	4	1.2
16.7	440	B32344B4201 A 40	21.9	3 x 91.5	85 x 345	1	4	1.2
19	440	B32344B4192 A 40	24.9	3 x 104.5	85 x 345	1	4	1.2
20	440	B32344B4202 A 40	26.2	3 x 110	85 x 345	1	4	1.2
20.8	440	B32344B4251 A 40	27.3	3 x 114	85 x 345	1	4	1.2
25	440	B32344B4252 A 40	32.8	3 x 137.5	90 x 345	1	4	1.5
28	440	B32344B4282 A 40	36.7	3 x 153.5	90 x 345	1	4	1.6
30	440	B32344B4302A 40	39.4	3 x 164.5	90 x 345	1	4	1.

PhiCap PFC Capacitors

Semi-dry biodegradable resin • Stacked winding • Dual safety system

PhiCap Normal Duty (ND) capacitors - 3 Phase								
Rating KVAR	Voltage V (AC)	Material code	I _r A	C _N μF	d x h mm	Packing units	MOQ	Approx. weight Kg
PhiCap Normal Duty - 480 V(AC) 3PH, 50Hz (Series B32344)								
5	480	B32343F4052A 80	6	3 x 23.0	63.5 x 152	12	12	0.6
8.3	480	B32344F4082A 380	10	3 x 38.2	78.4 x 164	6	6	0.8
10.4	480	B32344F4102A 480	12.5	3 x 47.9	78.4 x 197	6	6	0.96
11.1	480	B32344F4112A 180	13.4	3 x 51.1	78.4 x 197	6	6	0.96
12.5	480	B32344F4122A 580	15	3 x 57.6	78.4 x 197	6	6	0.96
13.8	480	B32344B4132A 880	16.6	3 x 63.6	85 x 270	1	4	1.0
15	480	B32344F4152A 80	18.0	3 x 69	85 x 345	1	4	1.5
16.8	480	B32344F4162A 680	20	3 x 76.5	85 x 345	1	4	1.5
20.8	480	B32344F4215A 80	25	3 x 96	85 x 345	1	4	1.5
22.1	480	B32344F41222A 180	26.6	3 x 101.8	90 x 345	1	4	1.8
25	480	B32344F4252A 80	30	3 x 115	90 x 345	1	4	1.8
27.7	480	B32344F4272A 680	33.3	3 x 127.6	90 x 345	1	4	1.8
30	480	B32344F4302A 680	36	3 x 138	90 x 345	1	4	1.9
PhiCap Normal Duty - 525 V(AC) 3PH, 50Hz (Series B32344)								
5	525	B32343F5052A 20	5.5	3 x 19.2	63.5 x 152	12	12	0.6
6.3	525	B32343F5062A 320	6.9	3 x 24.2	63.5 x 152	12	12	0.6
8.3	525	B32344F5082A 320	9.1	3 x 31.9	78.4 x 164	6	6	0.8
9.9	525	B32344F5092A 920	10.9	3 x 38.1	78.4 x 197	6	6	0.96
10.4	525	B32344F5102A 420	11.4	3 x 40.0	78.4 x 197	6	6	0.96
12.5	525	B32344F5122A 520	13.7	3 x 48.1	88.4 x 197	4	4	1.23
13.2	525	B32344B5132A220	14.5	3 x 50.8	85 x 270	1	4	1.3
16.7	525	B32344B5162A720	18.3	3 x 64	85 x 345	1	4	1.3
20.8	525	B32344B5202A820	22.8	3 x 80	90 x 345	1	4	1.5
26.5	525	B32344B5262A520	29.5	3 x 102.1	116 x 325	1	2	1.8
33.1	525	B32344B5332A120	36.4	3 x 127.5	116 x 325	1	2	2.0

Other voltages available on request.

Packing units for capacitors equal minimum order quantity. Orders will be rounded up to packing unit or multiple thereof.

PhiCap PFC Capacitors

Semi-dry biodegradable resin • Stacked winding • Dual safety system

Dimensional drawings:

Capacitor B32344 series

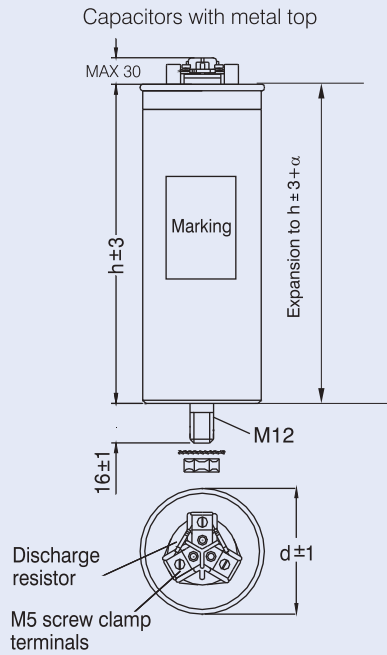

- 1) Seaming adds 5.5 mm in diameter
- 2) Expansion α max. 15 mm

Capacitor B32343 series

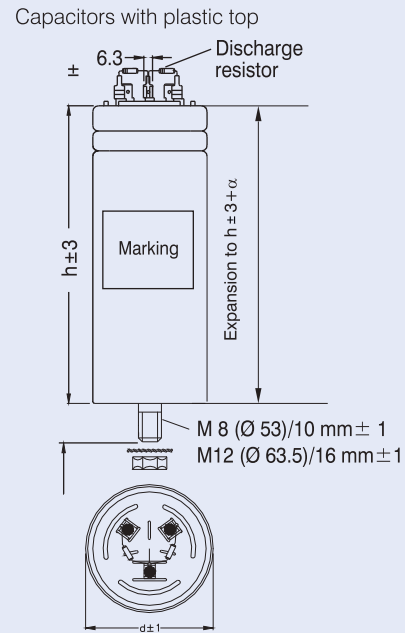

SquareCap PFC Capacitors

Semi-dry biodegradable resin • Modular construction • Triple safety system

General

The SquareCap box type capacitor is self standing in nature and is having modular construction (above 6KVA_r) in a sheet metal enclosure.

It is a very popular capacitor design in India for many decades.

The SquareCap series is especially intended for use in industrial applications and locations such as commercial complexes, malls etc. The internal construction comprises of single phase basic capacitors cells connected to form delta construction externally within the enclosure. The terminal arrangement is of stud type.

SquareCap series is available in three designs:

ENDC: EPCOS Normal Duty Capacitor for normal inductive loads.

EHDLL: EPCOS Heavy Duty Long life Capacitor for loads exhibiting some amount of non-linearity. (Preferably with detuning reactor).

ESHDC: EPCOS Super Heavy Duty Capacitor for non linear arduous and fluctuating loads and systems containing higher degree of harmonics. (Preferably with detuning reactor).



Applications

- Stand alone capacitors (Fixed Compensation)
- Capacitor banks
- Detuned capacitor banks
- Dynamic PFC

Features

- Box Type self standing Design
- Voltage Range: 415V ... 525V
- Range: 1kVA_r to 60kVA_r
- Resin Impregnated
- Available in three designs Viz. ENDC, EHDLL and ESHDC

Electrical

- High pulse current withstand capability
- Very high life expectancy

Mechanical and maintenance

- Reduced mounting costs
- Maintenance-free

Safety

- Self-healing
- Overpressure disconnecter
- Sheet metal enclosure

SquareCap PFC Capacitors

Semi-dry biodegradable resin • Modular construction • Triple safety system

Technical data : SquareCap PFC capacitors			
	SquareCap-ENDC	SquareCap-EHDLL	SquareCap-ESHDC
Series type	B32457L	B32459L	B32455L
Power-KVAr	1...50 KVAr	1...50 KVAr	1...50 KVAr
Rated voltage-V (AC)	415...440V*	415...525 V*	415...525 V*
Frequency	50 Hz	50 Hz	50 Hz
Transient peak current maximum permissible	upto $100 \cdot I_R$	upto $250 \cdot I_R$	upto $350 \cdot I_R$
Maximum permissible temperature category	-10/D	-10/D	-10/D
Losses (without discharge resistors)	≤ 0.5 W/KVAr	≤ 0.5 W/KVAr	≤ 0.5 W/KVAr
Maximum permissible voltage	$V_R + 10\%$ (up to 8 h daily)/ $V_R + 15\%$ (up to 30 min daily)** $V_R + 20\%$ (up to 5 min daily)/ $V_R + 30\%$ (up to 1 min daily)**	$V_R + 10\%$ (up to 8 h daily)/ $V_R + 15\%$ (up to 30 min daily)** $V_R + 20\%$ (up to 5 min daily)/ $V_R + 30\%$ (up to 1 min daily)**	$V_R + 10\%$ (up to 8 h daily)/ $V_R + 15\%$ (up to 30 min daily)** $V_R + 20\%$ (up to 5 min daily)/ $V_R + 30\%$ (up to 1 min daily)**
Maximum permissible current	$1.3 \cdot I_R^{***}$	$1.5 \cdot I_R^{***}$	$1.6 \cdot I_R^{***}$
Safety	Self-healing, overpressure disconnecter	Self-healing, overpressure disconnecter	Self-healing, overpressure disconnecter
Impregnation	Non PCB, semi-dry biodegradable resin	Non PCB, semi-dry biodegradable resin	Non PCB, semi-dry biodegradable resin
Life expectancy	Up to 100 000 hours	Up to 125 000 hours	Up to 150 000 hours
Cooling	Natural or forced	Natural or forced	Natural or forced
Case shape/finish	Rectangular/powder coated Siemens grey colour	Rectangular/powder coated Siemens grey colour	Rectangular/powder coated Siemens grey colour
Terminal	Threaded stud terminals with ceramic bushing	Threaded stud terminals with ceramic bushing	Threaded stud terminals with ceramic bushing
Mounting and grounding	Self standing with mounting plates and screws for grounding	Self standing with mounting plates and screws for grounding	Self standing with mounting plates and screws for grounding
Enclosure	IP 20	IP 20	IP 20
Discharge resistor	PCB mounted -included	PCB mounted -Included	PCB mounted -included
Connection	Delta	Delta	Delta
Casing of capacitor cell	Extruded aluminium can (hermetically sealed)	Extruded aluminium can (hermetically sealed)	Extruded aluminium can (hermetically sealed)
Dielectric	Polypropylene film (metallised)	Polypropylene film (metallised)	Polypropylene film (metallised)
No. of switching per annum	Max. 5000 switching	Max. 5000 switching	Max. 7500 switching
Reference standard	IS: 13340	IS: 13340	IS: 13340

* other voltages available on request

** V_R rated voltage

*** I_R : RMS line current that occurs at rated sinusoidal voltage and rated frequency, excluding transients.

Note : for capacitors with different features/parameters than above, please check with our nearest sales office

SquareCap PFC Capacitors

Semi-dry biodegradable resin • Modular construction • Triple safety system

SquareCap ENDC capacitors - 3 Phase								
Rating KVAR	Voltage V (AC)	Material code	I _R A	C _{N1} μF (Basic cells x μF)	H x W x D mm	Packing units	MOQ	Approx. weight Kg
SquareCap ENDC - 415 V(AC) 3PH, 50Hz (Series B32457)								
1	415	B32457P4001A 11	1.3	3 x 6.3	95 x 125 x 45	1	25	0.8
2	415	B32457P4002A 11	2.7	3 x 12.5	120 x 125 x 45	1	25	0.8
3	415	B32457P4003A 11	4.1	3 x 19	120 x 145 x 55	1	25	1.4
4	415	B32457P4004A 11	5.5	3 x 25	140 x 145 x 55	1	25	1.5
5	415	B32457L4005A 11	6.9	3 x 31	215 x 185 x 60	1	1	1.6
6	415	B32457L4006A 11	8.3	3 x 37.5	285 x 185 x 60	1	1	2.4
7	415	B32457L4007A 11	9.7	3 x 44	285 x 185 x 60	1	1	2.6
7.5	415	B32457L4007A511	10.4	3 x 46.5	285 x 185 x 60	1	1	2.7
8	415	B32457L4008A 11	11.1	3 x 49.5	285 x 185 x 60	1	1	2.8
9	415	B32457L4009A 11	12.5	3 x 56	285 x 185 x 60	1	1	3.0
10	415	B32457L4010A 11	13.9	3 x 62	285 x 185 x 60	1	1	3.1
12.5	415	B32457L4012A511	17.3	3 x 77	300 x 240 x 80	1	1	3.6
15	415	B32457L4015A 11	20.8	3 x 92.5	300 x 240 x 80	1	1	3.8
20	415	B32457L4020A 11	27.8	6 x 62	300 x 240 x 160	1	1	6.5
25	415	B32457L4025A 11	34.7	6 x 77	300 x 240 x 160	1	1	7.2
30	415	B32457L4030A 11	41.7	6 x 92.5	300 x 240 x 160	1	1	7.9
50	415	B32457L4050A 11	69.5	12 x 77	350 x 240 x 320	1	1	12.5
SquareCap ENDC - 440 V(AC) 3PH, 50Hz (Series B32457)								
1	440	B32457P5001A 11	1.3	3 x 5.5	95 x 125 x 45	1	25	0.8
2	440	B32457P5002A 11	2.6	3 x 11	120 x 125 x 45	1	25	0.8
3	440	B32457P5003A 11	3.9	3 x 16.5	120 x 145 x 55	1	25	1.4
4	440	B32457P5004A 11	5.2	3 x 22	140 x 145 x 55	1	25	1.5
5	440	B32457L5005A 11	6.6	3 x 27.5	215 x 185 x 60	1	1	1.6
6	440	B32457L5006A 11	7.9	3 x 33	285 x 185 x 60	1	1	2.2
7	440	B32457L5007A 11	9.2	3 x 38.5	285 x 185 x 60	1	1	2.4
7.5	440	B32457L5007A511	9.84	3 x 41.5	285 x 185 x 60	1	1	2.5
8	440	B32457L5008A 11	10.5	3 x 44	285 x 185 x 60	1	1	2.6
9	440	B32457L5009A 11	11.8	3 x 49.5	285 x 185 x 60	1	1	2.8
10	440	B32457L5010A 11	13.1	3 x 55	285 x 185 x 60	1	1	3.0
12	440	B32457L5012A 11	15.7	3 x 66	300 x 240 x 80	1	1	3.2
12.5	440	B32457L5012A511	16.4	3 x 69	300 x 240 x 80	1	1	3.3
15	440	B32457L5015A 11	19.6	3 x 82.5	300 x 240 x 80	1	1	3.8
20	440	B32457F5020A 11	26.2	3 x 109.7	300 x 240 x 80	1	1	6.1
25	440	B32457F5025A 11	32.8	3 x 137.1	300 x 240 x 80	1	1	7.0
40	440	B32457F5040A 11	52.5	6 x 109.7	350 x 240 x 160	1	1	8.8
50	440	B32457F5050A 11	65.6	6 x 137.1	350 x 240 x 160	1	1	12.4

SquareCap PFC Capacitors

Semi-dry biodegradable resin • Modular construction • Triple safety system

SquareCap EHDLL capacitors - 3 Phase								
Rating KVAR	Voltage V (AC)	Material code	I _r A	C _N μF (Basic cells x μF)	H x W x D mm	Packing units	MOQ	Approx. weight Kg
SquareCap EHDLL - 415 V(AC) 3PH, 50Hz (Series B32459)								
1	415	B32459L4001A 11	1.3	3 x 6.3	170 x 125 x 45	1	20	1.0
2	415	B32459L4002A 11	2.7	3 x 12.5	170 x 125 x 45	1	20	1.1
3	415	B32459L4003A 11	4.1	3 x 19	215 x 185 x 60	1	20	1.5
4	415	B32459L4004A 11	5.5	3 x 25	215 x 185 x 60	1	20	1.6
5	415	B32459L4005A 11	7.0	3 x 31	215 x 185 x 60	1	1	1.8
7	415	B32459L4007A 11	10.4	3 x 46.5	300 x 240 x 80	1	1	3.2
7.5	415	B32459L4007A511	10.4	3 x 49.5	300 x 240 x 80	1	1	3.3
10	415	B32459L4010A 11	13.9	3 x 62	300 x 240 x 80	1	1	3.4
12.5	415	B32459L4012A511	17.3	3 x 77	300 x 240 x 80	1	1	3.5
15	415	B32459L4015A 11	20.8	3 x 92	300 x 240 x 80	1	1	4.0
20	415	B32459L4020A 11	27.8	6 x 62	300 x 240 x 160	1	1	6.1
25	415	B32459L4025A 11	34.7	6 x 77	300 x 240 x 160	1	1	6.5
30	415	B32459L4030A 11	41.7	6 x 92.4	300 x 240 x 160	1	1	7.5
40	415	B32459L4040A 11	55.6	12 x 61.6	350 x 240 x 320	1	1	11.0
50	415	B32459L4050A 11	69.5	12 x 77	350 x 240 x 320	1	1	11.8
SquareCap EHDLL - 440 V(AC) 3PH, 50Hz (Series B32459)								
1	440	B32459L5001A 11	1.3	3 x 5.5	170 x 125 x 45	1	20	0.9
2	440	B32459L5002A 11	2.6	3 x 11	170 x 125 x 45	1	20	0.9
3	440	B32459L5003A 11	3.9	3 x 16.5	215 x 185 x 60	1	20	1.5
4	440	B32459L5004A 11	5.2	3 x 22	215 x 185 x 60	1	20	1.5
5	440	B32459L5005A 11	6.5	3 x 27.5	215 x 185 x 60	1	1	1.6
6	440	B32459L5006A 11	7.9	3 x 33	300 x 240 x 80	1	1	2.7
7	440	B32459L5007A 11	9.2	3 x 38.5	300 x 240 x 80	1	1	3.0
7.5	440	B32459L5007A511	9.8	3 x 41.5	300 x 240 x 80	1	1	3.0
8	440	B32459L5008A 11	10.5	3 x 44	300 x 240 x 80	1	1	3.2
9	440	B32459L5009A 11	11.8	3 x 50	300 x 240 x 80	1	1	3.3
10	440	B32459L5010A 11	13.1	3 x 55	300 x 240 x 80	1	1	3.3
12	440	B32459L5012A 11	15.8	3 x 67.5	300 x 240 x 80	1	1	3.4
12.5	440	B32459L5012A511	16.4	3 x 69	300 x 240 x 80	1	1	3.4
15	440	B32459L5015A 11	19.6	3 x 82.5	300 x 240 x 80	1	1	3.5
20	440	B32459L5020A 11	26.2	6 x 55	300 x 240 x 160	1	1	6.1
25	440	B32459L5025A 11	32.8	6 x 69	300 x 240 x 160	1	1	6.3
30	440	B32459L5030A 11	39.4	6 x 82.2	300 x 240 x 160	1	1	6.5
40	440	B32459L5040A 11	52.5	12 x 54.8	350 x 240 x 320	1	1	11.0
50	440	B32459L5050A 11	65.6	12 x 69	350 x 240 x 320	1	1	12.1
60	440	B32459L5060A 11	78.7	12 x 82.2	350 x 240 x 320	1	1	12.1

SquareCap PFC Capacitors

Semi-dry biodegradable resin • Modular construction • Triple safety system

SquareCap EHDLL capacitors - 3 Phase								
Rating KVA _r	Voltage V (AC)	Material code	I _R A	C _N μF (Basic cells x μF)	H x W x D mm	Packing units	MOQ	Approx. weight
SquareCap EHDLL - 480 V(AC) 3PH, 50Hz (Series B32459)								
5	480	B32459L8005A 61	6.0	3 x 23	215 x 185 x 60	1	1	1.8
5.5	480	B32459L8005A561	6.6	3 x 25.3	215 x 185 x 60	1	1	2.3
6	480	B32459L8006A 61	7.2	3 x 28	300 x 240 x 80	1	1	2.6
7.5	480	B32459L8007A561	9.0	3 x 34.5	300 x 240 x 80	1	1	2.8
8.3	480	B32459L8008A361	10	3 x 38.2	300 x 240 x 80	1	1	2.9
9	480	B32459L8009A 61	10.8	3 x 41.5	300 x 240 x 80	1	1	3.0
10	480	B32459L8010A 61	12.0	3 x 46.5	300 x 240 x 80	1	1	3.1
11.1	480	B32459L8011A161	13.4	3 x 51.1	300 x 240 x 80	1	1	3.2
12	480	B32459L8012A 61	14.4	3 x 55.5	300 x 240 x 80	1	1	3.3
12.5	480	B32459L8012A561	14.4	3 x 58	300 x 240 x 80	1	1	3.3
13.8	480	B32459L8013A861	16.6	3 x 63.6	300 x 240 x 80	1	1	3.4
14.5	480	B32459L8014A561	17.4	3 x 67.5	300 x 240 x 80	1	1	3.4
15	480	B32459L8015A 61	18.0	3 x 69	300 x 240 x 80	1	1	3.5
16.6	480	B32459L8016A661	20	3 x 76.4	300 x 240 x 160	1	1	3.5
18	480	B32459L8018A 61	21.6	6 x 41.5	300 x 240 x 160	1	1	5.8
20	480	B32459L8020A 61	24.0	6 x 46.5	300 x 240 x 160	1	1	6.0
22.1	480	B32459L8022A161	26.6	6 x 51.1	300 x 240 x 160	1	1	6.2
25	480	B32459L8025A 61	30.0	6 x 58	300 x 240 x 160	1	1	6.3
27.7	480	B32459L8027A761	33.3	6 x 63.6	300 x 240 x 160	1	1	6.5
29	480	B32459L8029A 61	34.8	6 x 67.5	300 x 240 x 160	1	1	6.7
50	480	B32459L8050A 61	60.1	12 x 58	350 x 240 x 320	1	1	11.2
55	480	B32459L8055A 61	66.1	12 x 63.5	350 x 240 x 320	1	1	11.4
SquareCap EHDLL - 525 V(AC) 3PH, 50Hz (Series B32459)								
6.6	525	B32459L6006A611	7.3	3 x 25.4	300 x 240 x 80	1	1	1.8
10	525	B32459L6010A 11	11	3 x 38.5	300 x 240 x 80	1	1	3.0
12.5	525	B32459L6012A511	13.7	3 x 48	300 x 240 x 80	1	1	3.2
13.2	525	B32459L6013A211	14.5	3 x 50.8	300 x 240 x 80	1	1	3.3
15	525	B32459L6015A 11	16.5	3 x 58	300 x 240 x 80	1	1	3.4
16.6	525	B32459L6016A611	18.3	3 x 63.9	300 x 240 x 160	1	1	3.5
19.9	525	B32459L6019A911	22	3 x 76.6	300 x 240 x 160	1	1	3.6
20	525	B32459L6020A 11	21.9	6 x 38.5	300 x 240 x 160	1	1	5.8
25	525	B32459L6025A 11	27.4	6 x 48	300 x 240 x 160	1	1	6.5
26.5	525	B32459L6026A511	29.1	6 x 50.8	300 x 240 x 160	1	1	6.5
30	525	B32459L6030A 11	32.9	6 x 58	300 x 240 x 160	1	1	6.8
33.1	525	B32459L6033A111	36.4	6 x 63.9	300 x 240 x 160	1	1	7.0
50	525	B32459L6050A 11	55	12 x 48	350 x 240 x 320	1	1	11.0

SquareCap PFC Capacitors

Semi-dry biodegradable resin • Modular construction • Triple safety system

SquareCap ESHDC capacitors - 3 Phase								
Rating KVAR	Voltage V (AC)	Material code	I _R A	C _N μF (Basic cells x μF)	H x W x D mm	Packing units	MOQ	Approx. weight Kg
SquareCap ESHDC - 480 V(AC) 3PH, 50Hz (Series B32455)								
5	480	B32455L8005A 11	6.0	3 x 23	300 x 240 x 80	1	1	2.9
5.5	480	B32455L8005A561	6.6	3 x 25.3	300 x 240 x 80	1	1	3.1
6	480	B32455L8006A 11	7.2	3 x 28	405 x 225 x 80	1	1	4.0
7.5	480	B32455L8007A511	9.0	3 x 34.5	405 x 225 x 80	1	1	4.3
8	480	B32455L8008A 11	9.6	3 x 37	405 x 225 x 80	1	1	4.4
8.3	480	B32455L8008A361	10	3 x 38.2	405 x 225 x 80	1	1	4.4
9	480	B32455L8009A 11	10.8	3 x 41.5	405 x 225 x 80	1	1	4.5
10	480	B32455L8010A 11	12.0	3 x 46	405 x 225 x 80	1	1	4.5
11.1	480	B32455L8011A161	13.4	3 x 51.1	405 x 225 x 80	1	1	4.6
12	480	B32455L8012A 11	14.4	3 x 55.5	405 x 225 x 80	1	1	4.6
12.5	480	B32455L8012A511	15.0	3 x 58	405 x 225 x 80	1	1	4.8
13.8	480	B32455L8013A861	16.6	3 x 63.5	405 x 225 x 80	1	1	5.2
14.5	480	B32455L8014A511	17.4	6 x 33.5	400 x 225 x 155	1	1	7.8
15	480	B32455L8015A 11	18.0	6 x 34.5	400 x 225 x 155	1	1	7.8
16.6	480	B32455L8016A661	20	6 x 38.2	400 x 225 x 155	1	1	7.9
18	480	B32455L8018A 11	21.6	6 x 41.5	400 x 225 x 155	1	1	7.9
20	480	B32455L8020A 11	24.0	6 x 46	400 x 225 x 155	1	1	8.1
22.1	480	B32455L8022A161	26.6	6 x 51.1	400 x 225 x 155	1	1	8.3
25	480	B32455L8025A 11	30.0	6 x 58	400 x 225 x 155	1	1	8.5
27.7	480	B32455L8027A761	33.3	6 x 63.5	400 x 225 x 155	1	1	9.0
29	480	B32455L8029A 11	34.8	12 x 33.5	450 x 325 x 225	1	1	14.0
50	480	B32455L8050A 11	60.1	12 x 58	450 x 325 x 225	1	1	17.5
SquareCap ESHDC - 525 V(AC) 3PH, 50Hz (Series B32455)								
6.6	525	B32455L6006A611	7.3	3 x 25.4	405 x 225 x 80	1	1	3.2
10	525	B32455L6010A 11	11	3 x 38.5	405 x 225 x 80	1	1	4.4
12.5	525	B32455L6012A511	13.7	3 x 48	405 x 225 x 80	1	1	4.6
13.2	525	B32455L6013A211	14.5	3 x 50.8	405 x 225 x 80	1	1	4.6
15	525	B32455L6015A 11	16.5	6 x 28.9	400 x 225 x 155	1	1	7.7
16.6	525	B32455L6016A611	18.3	6 x 32	400 x 225 x 155	1	1	7.8
20	525	B32455L6020A 11	21.9	6 x 38.5	400 x 225 x 155	1	1	8.1
25	525	B32455L6025A 11	27.4	6 x 48	400 x 225 x 155	1	1	8.3
26.5	525	B32455L6026A511	29.1	6 x 50.8	400 x 225 x 155	1	1	8.5
33.1	525	B32455L6033A111	36.4	12 x 32	450 x 325 x 225	1	1	14.5
35	525	B32455L6035A 11	38.4	12 x 34	450 x 325 x 225	1	1	14.5
50	525	B32455L6050A 11	54.9	12 x 48	450 x 325 x 225	1	1	17.5

SquareCap PFC Capacitors

Semi-dry biodegradable resin • Modular construction • Triple safety system

SquareCap ESHDC capacitors - 3 Phase								
Rating KVAR	Voltage V (AC)	Material code	I _R A	C _N μF (Basic cells x μF)	H x W x D mm	Packing units	MOQ	Approx. weight Kg
SquareCap ESHDC - 415 V(AC) 3PH, 50Hz(Series B32455)								
1	415	B32455L4001A 11	1.3	3 x 6.5	270 x 170 x 55	1	10	2.1
2	415	B32455L4002A 11	2.7	3 x 12.5	270 x 170 x 55	1	10	2.1
3	415	B32455L4003A 11	4.1	3 x 19	300 x 240 x 80	1	10	2.8
4	415	B32455L4004A 11	5.5	3 x 25	300 x 240 x 80	1	10	2.9
5	415	B32455L4005A 11	6.9	3 x 31	300 x 240 x 80	1	1	3.2
7.5	415	B32455L4007A511	10.4	3 x 46.5	405 x 225 x 80	1	1	4.6
8	415	B32455L4008A 11	11.1	3 x 49.5	405 x 225 x 80	1	1	4.7
10	415	B32455L4010A 11	13.9	3 x 62	405 x 225 x 80	1	1	5.0
12.5	415	B32455L4012A511	17.3	3 x 77	405 x 225 x 80	1	1	5.8
15	415	B32455L4015A 11	20.8	6 x 46.5	400 x 225 x 155	1	1	8.2
20	415	B32455L4020A 11	27.8	6 x 62	400 x 225 x 155	1	1	8.5
25	415	B32455L4025A 11	34.7	6 x 77	400 x 225 x 155	1	1	8.8
30	415	B32455L4030A 11	41.7	12 x 46.2	450 x 325 x 225	1	1	14.0
40	415	B32455L4040A 11	55.6	12 x 61.6	450 x 325 x 225	1	1	15.5
50	415	B32455L4050A 11	69.5	12 x 77	450 x 325 x 225	1	1	17.0
SquareCap ESHDC - 440 V(AC) 3PH, 50Hz (Series B32455)								
1	440	B32455L5001A 11	1.3	3 x 5.5	270 x 170 x 55	1	10	2.0
2	440	B32455L5002A 11	2.6	3 x 11	270 x 170 x 55	1	10	2.0
3	440	B32455L5003A 11	3.9	3 x 16.5	300 x 240 x 80	1	10	2.7
4	440	B32455L5004A 11	5.2	3 x 22	300 x 240 x 80	1	10	2.9
5	440	B32455L5005A 11	6.5	3 x 27.5	300 x 240 x 80	1	1	3.1
6	440	B32455L5006A 11	7.9	3 x 33	405 x 225 x 80	1	1	4.2
7	440	B32455L5007A 11	9.2	3 x 38.5	405 x 225 x 80	1	1	4.4
7.5	440	B32455L5007A511	9.8	3 x 41.5	405 x 225 x 80	1	1	4.5
8	440	B32455L5008A 11	10.5	3 x 44	405 x 225 x 80	1	1	4.6
9	440	B32455L5009A 11	11.8	3 x 49.5	405 x 225 x 80	1	1	4.7
10	440	B32455L5010A 11	13.1	3 x 55	405 x 225 x 80	1	1	4.8
12	440	B32455L5012A 11	15.7	3 x 67	405 x 225 x 80	1	1	5.2
12.5	440	B32455L5012A511	16.4	3 x 69	405 x 225 x 80	1	1	5.5
15	440	B32455L5015A 11	19.6	6 x 41.5	400 x 225 x 155	1	1	8.1
20	440	b32455L5020A 11	26.24	6 x 55	400 x 225 x 155	1	1	8.4
25	440	B32455L5025A 11	32.8	6 x 69	400 x 225 x 155	1	1	9.5
30	440	B32455L5030A 11	39.4	12 x 41.1	450 x 325 x 225	1	1	14.5
35	440	B32455L5035A 11	45.9	12 x 48	450 x 325 x 225	1	1	15.0
40	440	B32455L5040A 11	52.5	12 x 54.8	450 x 325 x 225	1	1	15.5
50	440	B32455L5050A 11	65.6	12 x 69	450 x 325 x 225	1	1	17.5

SquareCap PFC Capacitors

Semi-dry biodegradable resin • Modular construction • Triple safety system

SquareCap : Overall dimensions and information table

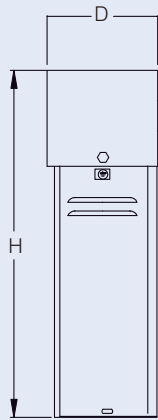
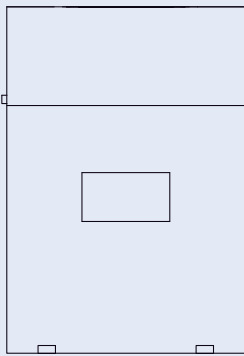
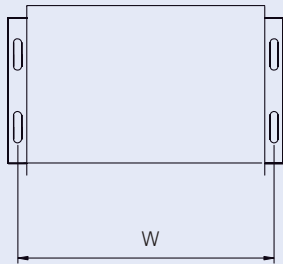

KVAR rating	Mounting brackets fixed/ separate/ sliding	Louvers/ holes	Basic cell	Mounting
ENDC/EHDLL				
1 to 2	fixed bracket	no	3	- - - -
3 to 5	fixed bracket	no	3	2 holes
6 to 15	seperate bracket	holes	3	2 slot
16 to 30	sliding bracket	2 louvers	6	4 slot
31 to 60	sliding bracket	8 louvers	6	12 slot
ESHDC				
1 to 2	fixed bracket	no	3	- - - -
3 to 5	fixed bracket	holes	3	2 slot
6 to 13	seperate bracket	holes	3	2 slot
14 to 25	sliding bracket	4 louvers	6	4 slot
26 to 50	sliding bracket	8 louvers	12	4 slot

SquareCap : Exploded view

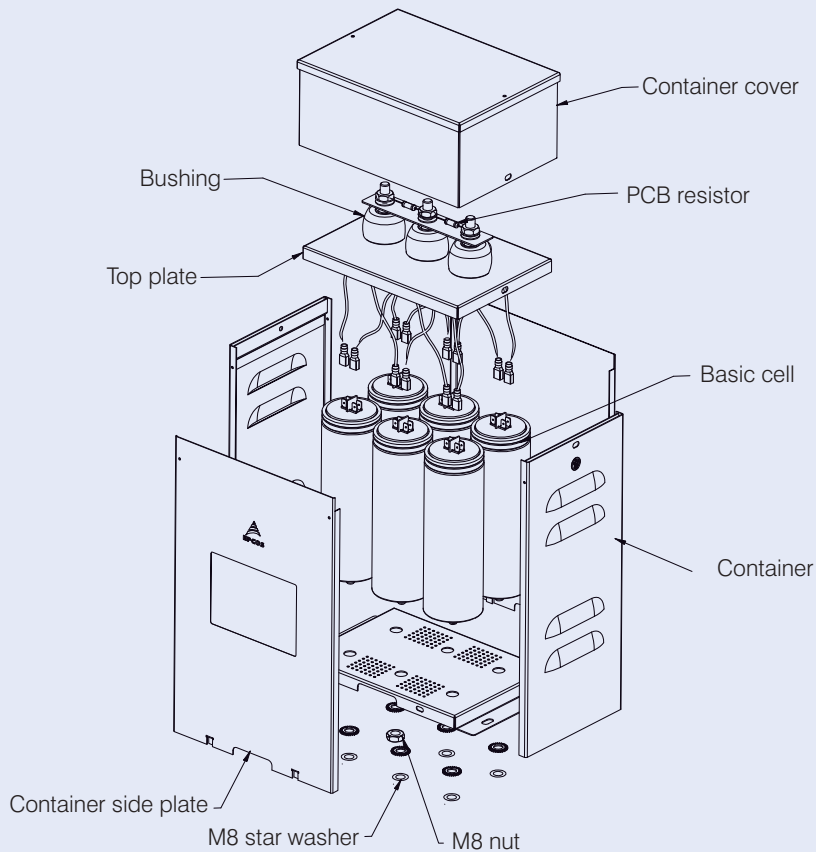

LT-APP Capacitors

NPCB Synthetic Oil impregnated • PP+AL Foil technology • Internal fuse protection

General

APP Capacitor is proven technology from more than 30 years. The combination of polypropylene film and aluminum foil makes the capacitor, more robust in varying conditions of the load.

The power range varies from 5 KVAR to 100 KVAR and voltage range varies from 240V to 1000V in three phase units. Single phase units are also available on demand.

The LT-APP capacitors are utilized in industry for sustaining large load variations, THD and hazardous conditions. With high qualitative manufacturing process, LT-APP capacitors offer higher life expectancy.



Applications

- Automated PFC Capacitor banks.
- Fixed PFC (e.g. – Motors, Transformers lighting etc.)
- Group compensation for larger load variation
- Tuned and detuned Capacitor
- Dynamic PFC and RTPFC
- Filter applications
- Product suitable for outdoor application, available on request.

Features

- Extended foil design
Low Energy consumption
- Natural air cooled.
- Voltage range 440, 480 525V
- Output range 5 KVAR to 66.2 KVAR.

Electrical

- Single phase and three phase
- Life expectancy 150,000 hrs. at STP
- Pulse current withstand capability – $300 \times I_R$
- Type tested according to IS –13585
- Low temperature rise.

Maintenance

- Maintenance free

Safety

- Internal fuse provided
- Hermetically Sealed construction. (CRCA or SS)

LT-APP Capacitors

NPCB Synthetic Oil impregnated • PP+AL Foil technology • Internal fuse protection

Technical data : LT-APP capacitors	
Series type	B25160C...
Power-KVAr	5 to 66.2 KVAr
Rated voltage-V (AC)	440, 480, 525 V* (available upto 750V on request)
Frequency	50 Hz /60Hz
Transient peak current maximum permissible	$300 \cdot I_R$
Maximum permissible temperature category	-5/D
Losses (without discharge resistors)	0.5 W/KVAr
Maximum permissible voltage	$V_R + 10\%$ (up to 8 h daily)/ $V_R + 15\%$ (up to 30 min daily)** $V_R + 20\%$ (up to 5 min daily)/ $V_R + 30\%$ (up to 1 min daily)**
Maximum permissible Current	$2 \cdot I_R^{***}$
Safety	Internal fuse provided
Impregnation	Non PCB synthetic oil
Life expectancy	150000 hours
Cooling	ONAN (Oil Natural Air Natural)
Case shape/Finish	Rectangular box spray painted
Terminal	M- 6, M- 8, M-10 thread brass terminal
Mounting and grounding	Self standing with rigid mounting bracket and a bracket for grounding
Enclosure	IP 20 with terminal cover (upto IP 4X on request)
Discharge resistor	Provided with external discharge resistor
Connection	Delta 3 Phase
Casing of capacitor cell	CRCA or SS container
Dielectric	Polypropylene film
No. of switching per annum	Max. 10000 switching
Reference standard	IS: 13585 (part - 1/2012)

* other voltages available on request

** V_R rated voltage

*** I_R : RMS line current that occurs at rated sinusoidal voltage and rated frequency, excluding transients.

Note : for capacitors with different features/parameters than above, please check with our nearest sales office

LT-APP Capacitors

NPCB Synthetic Oil impregnated • PP+AL Foil technology • Internal fuse protection

LT-APP capacitors - 3Phase								
Rating KVA _r	Voltage V (AC)	Material code	I _R A	C _N μF	D x W x H mm	Packing units	MOQ	Approx. weight Kg
LT - APP - 440 V(AC) 3PH, 50Hz (Series B25160)								
5	440	B25160C4005T 40	6.56	41.1	135 x 75 x 330	1	1	6
7.5	440	B25160C4007T540	9.84	61.65	135 x 85 x 330	1	1	6.5
10	440	B25160C4010T 40	13.12	82.2	135 x 115 x 330	1	1	8
12	440	B25160C4012T 40	16.4	102.75	155 x 115 x 330	1	1	9.5
15	440	B25160C4015T 40	19.68	123.3	175 x 115 x 330	1	1	10.5
20	440	B25160C4020T 40	26.24	164.39	225 x 115 x 355	1	1	13.5
25	440	B25160C4025T 40	32.8	205.49	195 x 115 x 455	1	1	15
30	440	B25160C4030T 40	39.37	246.59	225 x 115 x 455	1	1	17
40	440	B25160C4040T 40	52.49	329	275 x 115 x 455	1	1	20.5
50	440	B25160C4050T 40	65.61	410.99	335 x 115 x 455	1	1	25
LT - APP - 480 V(AC) 3PH, 50Hz (Series B25160)								
5	480	B25160C4005T 80	6.01	34.53	135 x 75 x 330	1	1	6
5.5	480	B25160C4005T580	6.62	37.99	135 x 75 x 330	1	1	6.5
7.5	480	B25160C4007T580	9.02	51.8	135 x 75 x 330	1	1	7
8.3	480	B25160C4008T380	9.98	57.33	135 x 85 x 330	1	1	7
10	480	B25160C4010T 80	12.03	69.07	135 x 100 x 330	1	1	7.5
11.1	480	B25160C4011T180	13.35	76.67	135 x 115 x 330	1	1	8.5
12.5	480	B25160C4012T580	15.04	86.34	135 x 115 x 330	1	1	8.5
13.8	480	B25160C4013T880	16.6	95.31	155 x 115 x 330	1	1	9.5
15	480	B25160C4015T 80	18.04	103.6	155 x 115 x 330	1	1	9.5
16.6	480	B25160C4016T680	19.97	114.65	175 x 115 x 330	1	1	10.5
20	480	B25160C4020T 80	24.06	138.14	195 x 115 x 355	1	1	12
22.1	480	B25160C4022T180	26.58	152.64	210 x 115 x 355	1	1	12.5
25	480	B25160C4025T 80	30.07	172.67	225 x 115 x 355	1	1	13.5
27.7	480	B25160C4027T780	33.28	191.11	185 x 115 x 455	1	1	14.5
30	480	B25160C4030T 80	36.09	207.21	195 x 115 x 455	1	1	15
33.2	480	B25160C4033T280	39.93	229.31	210 x 115 x 455	1	1	16.5
40	480	B25160C4040T 80	48.11	276.27	245 x 115 x 455	1	1	19
44.3	480	B25160C4044T380	53.29	305.97	275 x 115 x 455	1	1	20.5
50	480	B25160C4050T 80	60.14	345.34	295 x 115 x 455	1	1	22.5
55.3	480	B25160C4055T380	66.52	381.95	315 x 115 x 455	1	1	24
LT - APP - 525 V(AC) 3PH, 50Hz (Series B25160)								
5	525	B25160C5005T 25	5.5	28.87	135 x 115 x 230	1	1	6
6.6	525	B25160C5006T625	7.26	38.11	155 x 115 x 230	1	1	6.8
7.5	525	B25160C5007T525	8.25	43.3	185 x 115 x 230	1	1	8
8.3	525	B25160C5008T325	9.13	47.92	185 x 115 x 230	1	1	8
10	525	B25160C5010T 25	11	57.74	210 x 115 x 230	1	1	8.5
12.5	525	B25160C5012T525	13.75	72.17	135 x 115 x 330	1	1	8.5
13.2	525	B25160C5013T225	14.52	76.21	135 x 115 x 330	1	1	8.5
15	525	B25160C5015T 25	16.5	86.6	155 x 115 x 330	1	1	9.5
16.6	525	B25160C5016T625	18.26	95.84	175 x 115 x 330	1	1	10.5
20	525	B25160C5020T 25	21.99	115.47	195 x 115 x 355	1	1	12
25	525	B25160C5025T 25	27.49	144.34	225 x 115 x 355	1	1	13.5
26.5	525	B25160C5026T525	29.14	153	245 x 115 x 355	1	1	14.5
30	525	B25160C5030T 25	32.99	173.21	195 x 115 x 455	1	1	15.5
33.1	525	B25160C5033T125	36.4	191.11	210 x 115 x 455	1	1	16.5
40	525	B25160C5040T 25	43.99	230.94	245 x 115 x 455	1	1	18.5
50	525	B25160C5050T 25	54.99	288.68	295 x 115 x 455	1	1	22
53	525	B25160C5053T 25	58.29	306	295 x 115 x 455	1	1	23
66.2	525	B25160C5066T225	72.9	382.21	360 x 115 x 455	1	1	26.5

PF Controllers BR6000 Series

Intelligent • User-friendly • Cost-effective • Version 5.0

General

Controllers for PFC are of major importance in the PFC system. They measure the actual power factor and connect or disconnect capacitor stages to achieve a specific desired value ($\cos \varphi$).

The PF controller series and BR6000 (six and twelve stages) offer highly intelligent control behavior and are very user-friendly thanks to menu-driven handling (plain language). Their multifunctional display greatly simplifies installation, handling and maintenance.

Different versions of the BR6000 series provide solutions to various applications:

- BR6000-R6 and BR6000-R12 for conventional applications with slowly changing loads (optionally with RS485 interface)
- BR6000-T6 and BR6000-T12 for dynamic PFC in applications with fast-changing loads



Features

- Display
 - Large and multifunctional LCD (2 x 16 characters)
 - Graphic and alphanumeric LCD illumination
- Intelligent control
- Menu-driven handling (plain language)
- Self-optimizing control capability
- Recall function of recorded values
- Four-quadrant operation (e.g. stand-by generator)
- Large measuring voltage range
- Powerful alarm output
- Display of numerous of system parameters
 - System voltage (V AC)
 - Reactive power (KVar)
 - Active power (kW)
 - Frequency
 - THD-V, THD-I
 - Individual harmonics up to 19th*
 - Monitoring of individual capacitor currents
 - Apparent power (KVA)
 - Apparent current (A)
 - Temperature (°C)
 - Real-time $\cos \varphi$
 - Target $\cos \varphi$
 - KVar value to target $\cos \varphi$
- Alarm output
 - Insufficient compensation
 - Overcompensation
 - Undercurrent
 - Overcurrent
 - Overtemperature
 - Harmonics exceeded
 - Threshold value programmable
 - Internal error storage
 - Programming of 2nd signal relay random
 - Undervoltage and overvoltage
- Recall recorded values
 - Number of contactor switching operations
 - Maximum voltage V (Vmax)
 - Maximum reactive power, Q (KVar)
 - Maximum value of harmonic
 - Maximum active power, P (kW)
 - Maximum apparent power, S (KVA)
 - Maximum temperature (°C)
 - Operation time of all capacitors
 - Complete 2nd parameter set available
 - Automatic initialization
 - Dynamic PFC (transistor output)
 - Thyristor switching
- Dual target power factor setting (EB and DG) is available in selected models

⚠ Cautions:

1. Discharge time : Make sure that the discharge time set in controller matches the capacitor discharge time. See page 84
2. Number of switchings : LV PFC capacitors according to standard IEC 60831 are designed for up to 5000 switching operations. Make sure that 5000 switching operations per year are not exceeded.

PF Controllers BR6000 Series

Intelligent • User-friendly • Cost-effective • Version 5.0

PF Controller BR6000 R-12 : Relay output

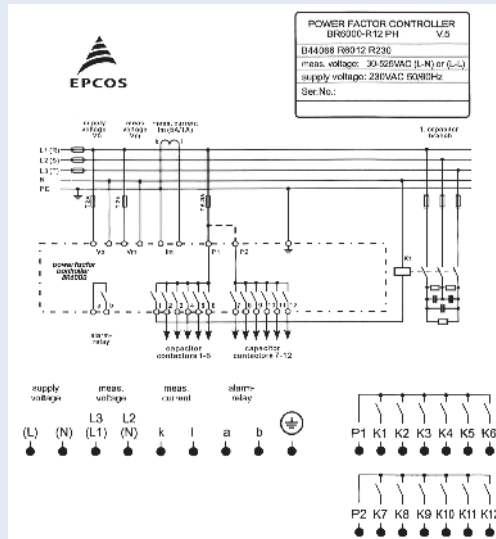

PF Controller BR6000 T- 6/12 : Transistor output

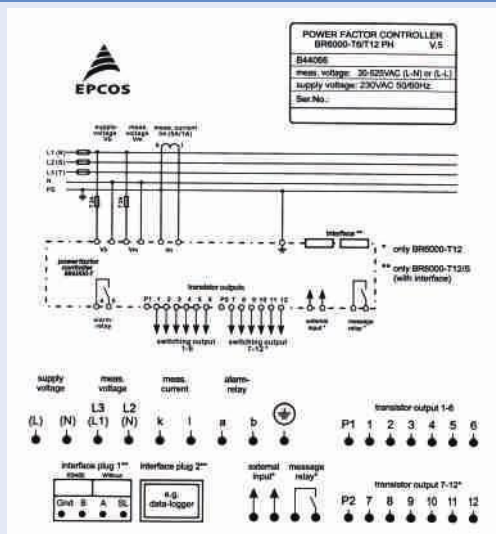

PF Controller BR6000 R-12 (RS 485) : Relay output

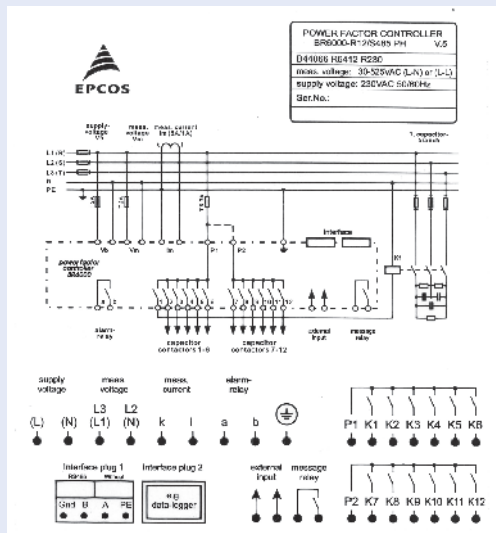

PF Controllers BR6000 Series

Intelligent • User-friendly • Cost-effective

Selection table for controllers				
	BR6000 relay output		BR6000 transistor output	
Steps	6 STEP	12 STEP	6 STEP	12 STEP
Switching	Contactor	Contactor	Thyristor	Thyristor
Ordering code	B44066R6006R230N1	B44066R6012R230N1	B44066R6106R230N1	B44066R6112R230N1
Auxiliary supply	1-Phase, 2-Wire, 245 Vac (-20% to +20%)	1-Phase, 2-Wire, 245 Vac (-20% to +20%)	1-Phase, 2-Wire, 245 Vac (-20% to +20%)	1-Phase, 2-Wire, 245 Vac (-20% to +20%)
Measurement voltage	30-525 V AC (L-N) or (L-L)	30-525 V AC (L-N) or (L-L)	1Ph 30-300 V AC (L-N)	1Ph 30-300 V AC (L-N)
Load CT Input current 1 / 5 A	1 / 5 A	1 / 5 A	1 / 5 A	
No. of outputs	6	12	6	12
Alarm outputs	1 No.	1 No.	1 No.	1 No.
- Insufficient Compensation	Yes	Yes	Yes	Yes
- Overcompensation	Yes	Yes	Yes	Yes
- Over / under voltage	Yes	Yes	Yes	Yes
- Overcurrent	Yes	Yes	Yes	Yes
Automatic Initialisation	Yes	Yes	Yes	Yes
Communication interface RSXXX	No	No*	No	No
Parameters displayed				
System voltage	Yes	Yes	Yes	Yes
Load current	Yes	Yes	Yes	Yes
Capacitor current	No	No	No	No
Active power	Yes	Yes	Yes	Yes
Reactive power	Yes	Yes	Yes	Yes
Apparent power	Yes	Yes	Yes	Yes
Frequency	Yes	Yes	Yes	Yes
Individual harmonics measurement upto	19	19	19	19
THD - V	Yes	Yes	Yes	Yes
THD - I	Yes	Yes	Yes	Yes
Monitoring of individual capacitor current	Yes - Health check	Yes - Health check	No	No
Apparent current	Yes	Yes	Yes	Yes
Overtemperature	Yes	Yes	Yes	Yes
Real time cos φ	Yes	Yes	Yes	Yes
Target cos φ	Yes	Yes	Yes	Yes
KVAr value to target cos φ	Yes	Yes	Yes	Yes
Switching and discharge time range				
- Correction time	1 sec - 20 min	1 sec - 20 min	20-1000 m sec	20-1000 m sec
- Discharge time	1 sec - 20 min	1 sec - 20 min	20-1000 m sec	20-1000 m sec
Number of control series	20 + E series	20 + E series	20 + E series	20 + E series
Weight (in kG)	1kG	1kG	1kG	1kG
Dimensions (L x D x H in mm)	144 x 55 x 144 mm	144 x 55 x 144 mm	144 x 53 x 144 mm	144 x 53 x 144 mm

*RS 232-B44066R6312R230N1

*RS 485-B44066R6412R230N1

PF Controllers BR5000 Series

Intelligent • User-friendly • Cost-effective

General

The BR5000 controller series is intended to be used with unbalanced three phase loading conditions and to correct the power factor. The controller needs 3 Load CT inputs and corresponding voltages. The overall compensation is done on averaging basis. The controller is having ultra intelligent processor in built. It covers almost all the electrical parameters to be displayed and monitored .

The three versions of BR5000 Controller are

- BR5000 – 16 for contactor switching logic for slow varying loads
- BR5000 – 16TX for rapidly changing loading conditions (Option for GSM communication available)
- BR5000 – HT for High tension upto 33kV sensing of power factors and correction. Version available in 8/16 steps.



Features

- Microcontroller logic for measurements
- Control mode: Binary, unequal, Preset and user defined
- Multifunctional LCD display
- Three CT sensing for unbalanced loads
- Dual target Power Factor setting- useful for utility and DG mode operation
- Automatic synchronization possible
- Separate 3 CT monitoring of healthiness of capacitor within panel
- Data logging
- RS 232 in front and RS 232/485 switchable connection at rear
- Step operation indication on LCD display plus LED which facilitates viewing from a distance
- Unique facility of including 'Fixed Capacitor Bank' for purpose of Transformer compensation. This can be set such that the controller doesn't 'see' this capacitor.
- Unique external temperature sensing by PT 100
- Settable alarm facility - undervoltage, overvoltage and so on
- Settable auxiliary outputs - 2 Nos for Alarm, etc.
- Auxiliary input -1 No
- EMI/EMC type tested
- Individual Harmonic measurement Upto 15th

Protection Warning

- Over / under voltage
- Capacitor over / under current
- Over / under frequency
- Load unbalance
- Over temperature
- Out of steps (Indication)
- NV-Ram battery down.

Important display parameters

- Voltage
- Current
- Active power
- Reactive power
- Apparent power
- Capacitor current
- Per phase values of V, I and neutral current
- Power factor
- Frequency
- V_{THD}
- I_{THD}

Technical Data

- Auxiliary supply voltage -1Ph, 415V (-40% to + 20%)
- Measurement voltage: 3PH 3 wire 415 VAC (-40% to + 20%)
- Current Input - 1A or 5A
- Steps - 8 and 16 relay outputs
- Supply frequency - 45 Hz to 62 Hz

Mechanical and Maintenance

- Operating temperature - 0° to 70°C
- Storage temperature - -10°C to +75°C
- Humidity - 0 to 98%.

Dynamic Power Factor Controller (Transistorised) available in 16 steps.

Special 8/16 step Controller for Medium Voltage application available.

PF Controller BR5000 Relay Output

Intelligent • User-friendly • Cost-effective

Typical wiring diagram for PF correction : Contactor switching

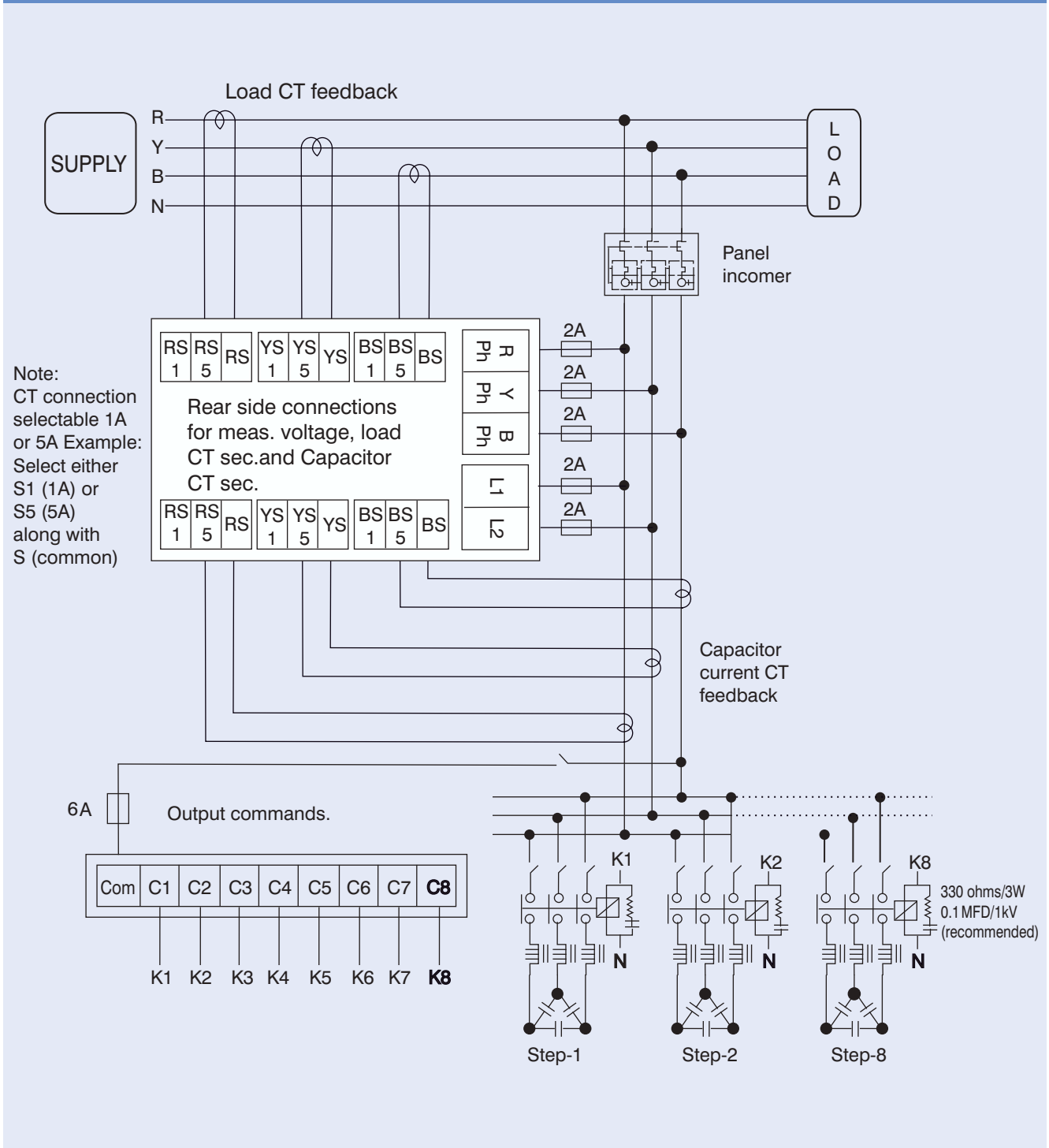

PF Controller BR5000 Transistor Output

Intelligent • User-friendly • Cost-effective

Typical wiring diagram for PF correction : TSM switching

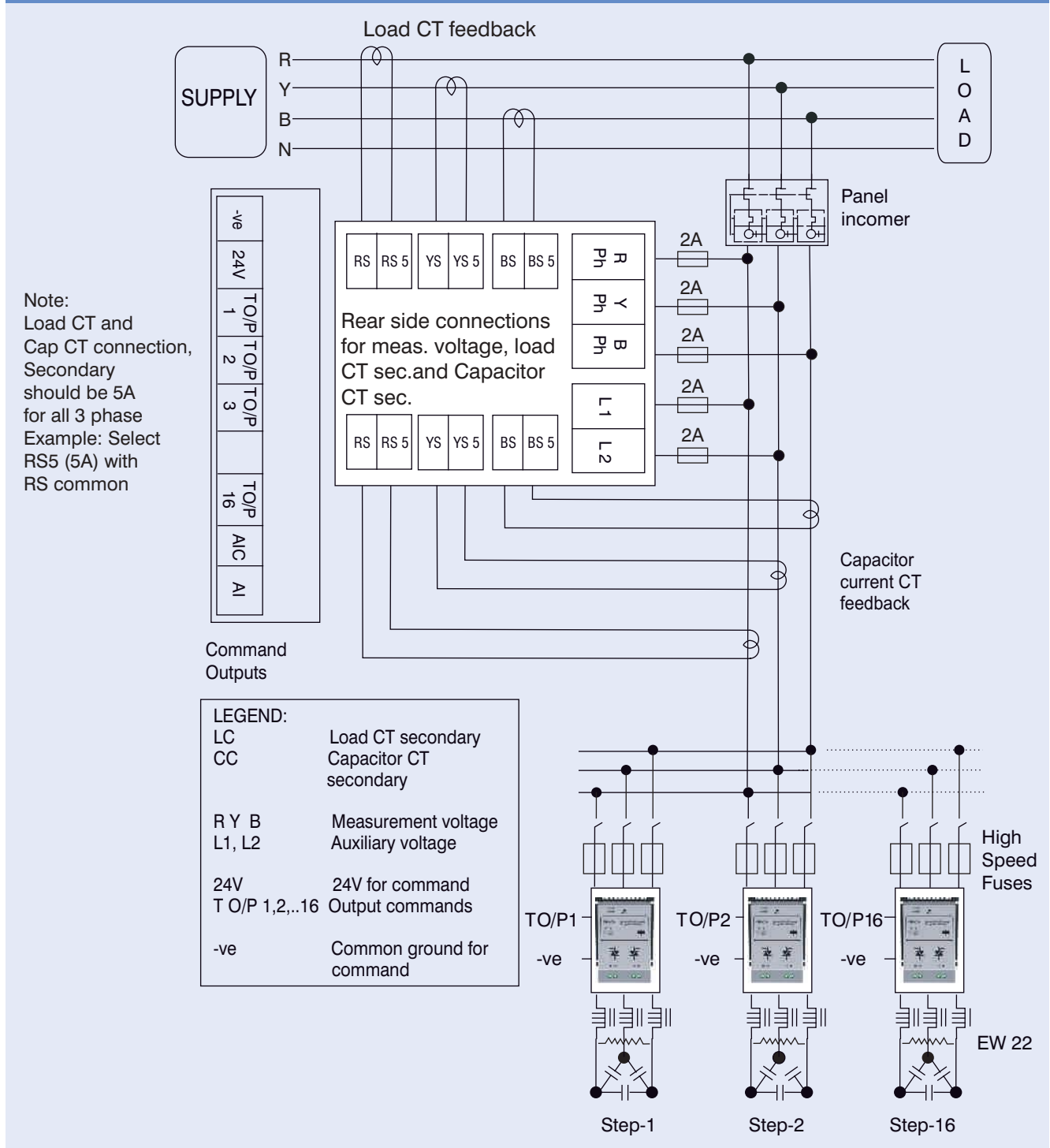

PF Controllers BR5000 Series

Intelligent • User-friendly • Cost-effective

Selection table for controllers			
	BR5000 relay output		BR5000 transistor output
Steps	8 STEP	16 STEP	16 STEP
Switching	Contactor	Contactor	Thyristor
Ordering code	B44066R5908A415N1	B44066R5916A415N1	B44066R5716A415N1
Auxiliary supply	1Ph 415V (-40% to +20%)	1Ph 415V (-40% to +20%)	1Ph 415V (-40% to +20%)
Measurement voltage	3Ph 3wire 415V (-40% to +20%)	3Ph 3wire 415V (-40% to +20%)	3Ph 3wire 415V (-40% to +20%)
Load CT Input current	1/5 A-separate connectors for either of the CT connections	1 / 5 A-separate connectors for either of the CT connections	only 5Amp CT secondary
No. of outputs	8 Nos. relay o/p of burden 1000VA by contactor coils	16 Nos. relay o/p of burden 1000VA by contactor coils	16 digital outputs maximum 20 mA loading
Alarm outputs	2 Nos.	2 Nos.	1 No.
-Insufficient Compensation	Yes	Yes	Yes (only display)
-Overcompensation	Yes	Yes	Yes
-Over / under voltage	Yes	Yes	Yes
-Overcurrent	Yes	Yes	Yes
Automatic initialisation		No	NoNo
Communication interface	RSXXX RS232 and RS485	RS232 and RS485	RS232 and RS485
Parameters displayed			--
System voltage	Yes	Yes	Yes
Load current	Yes	Yes	Yes
Capacitor current	No	No	No
Active power	Yes	Yes	Yes
Reactive power	Yes	Yes	Yes
Apparent power	Yes	Yes	Yes
Frequency	Yes	Yes	Yes
Individual harmonics measurement upto	15	15	15
THD - V	Yes	Yes	Yes
THD - I	Yes	Yes	Yes
Monitoring of individual capacitor current	Yes - Health check	Yes - Health check	Yes - total panel capacitor current monitored
Apparent current	Yes	Yes	Yes
Overtemperature	Yes	Yes (only INT temp.)	Yes
Real time cos ϕ	Yes	Yes	Yes
Target cos ϕ	Yes (upper and lower target PF- programmable)	Yes (upper and lower target PF- programmable)	Yes- (upper and lower target PF- programmable)
KVAr value to target cos ϕ	Yes - displayed as System reactive power	Yes - displayed as System reactive power	Yes - displayed as System reactive power
Switching and discharge time range			
-Correction time	1 - 600 sec	1 - 600 sec	20-5000 m sec
-Discharge time	1 - 600 sec	1 - 600 sec	NA
Number of control series	Unequal, C-series (1-15), E-series	Unequal, C-series (1-15), E-series	Binary, unequal C-series (1-15), E-series
Weight (in kG)	2.5 kG	2.5 kG	2.5 kG
Dimensions (L x D x H in mm)	144 x 125 x 144 mm	144 x 125 x 144 mm	144 x 125 x 144 mm

PF Controllers BR4000-ER Series

Intelligent • User-friendly • Cost-effective

General

The BR4000 controller series is the most economical series and intended to serve the basic purpose of power factor corrections... The simplest menu driven version controller with navigational keys. The microcontroller based logic, multifunctional display of electrical parameters, compact size 96 x 96 mm and protections makes this controller extremely user friendly.

BR4000 Controller series is available in 4 stages and 8 stages. Best suited with conventional APFC applications.



Features

- Microcontroller logic for measurements
- User friendly operation
- Control mode: binary, unequal, Preset and User defined
- Multifunctional LCD display
- Single CT sensing for unbalanced loads
- Compact 96X96 mm front fascia
- Suitable for auto / manual operation
- Individual harmonic measurement upto 15th.

Protection warning

- Over / under voltage
- Over / under load
- Over temperature
- User friendly operation

Important display parameters

- Voltage
- Current
- Active power
- Reactive power
- Apparent power
- Frequency
- V_{THD}
- I_{THD}.

Technical data

- Measurement voltage: 1PH 230 VAC (-25% to +20%)
- Current input selectable - 1A or 5A for load with class 2 accuracy
- Auxiliary supply - 1Ph, 230V (-25% to +20%)
- Steps - 4 and 8 relay outputs
- Supply frequency -47 Hz to 53 Hz

Mechanical and maintenance

- Compact size
- Operating temperature - 0° to 50° C
- Storage temperature - -5°C to 65°C
- Humidity -0 to 98%.

PF Controllers BR4000-ER Series

Intelligent • User-friendly • Cost-effective

Technical data	BR4000-ER
Series Type	B44066R4...R240
Steps	4,6 and 8 relay output
Supply Voltage	110....550V (L-N/L-L)
Measurement Voltage	30....550V (L-N/L-L)
Frequency (Selectable)	40 to 70 Hz
Switching	Contactors
Operating Temperature	-10°C to 60°C
Load CT input Current	1/5A
Parameter displayed	
System voltage (V AC)	Yes
Reactive power (KVAR)	Yes
Active power (kW)	Yes
Apparent power (KVA)	Yes
Apparent current (A)	Yes
Temperature (°C)	Yes
Real-time cos ϕ	Yes
KVAR value to target cos ϕ	Yes
THD – V / THD - I in %	Yes
Individual Harmonics in % up to 31st for V and I	Yes
Energy kWh (Import/ Export)	Yes
Energy KVAh	Yes
Energy KVARh (Inductive / Capacitive)	Yes
Demand KVA /current	Yes
Run Hour – Number of hours load is connected	Yes
On Hour – hours for which power supply is On	Yes
No of interruption – Number of interruption for power supply	Yes
Alarm Relay	Yes
Out of Bank (Under Compensation)	Yes
Overcompensation	Yes
Under Voltage	Yes
Over Voltage	Yes
Undercurrent	Yes
Overcurrent	Yes
Over temperature	Yes
Under / Over Frequency	Yes
Excess Harmonics (V-THD / I-THD)	Yes
Recall recorded values	
Maximum / Minimum Voltage	Yes
Maximum / Minimum current	Yes
Maximum / Minimum Apparent power	Yes
Maximum / Minimum Reactive power	Yes
Maximum / Minimum temperature	Yes
Maximum / Minimum THD (V/I)	Yes
Switching count of Capacitor	Yes
Operation time of Capacitor	Yes
Correction Time	10 sec ...30 min
Discharge Time	60 sec ...30 min
Dimension	96 × 96 × 51 mm*
Weight	0.35 Kg.

* Provided with 144 X 144 adaptor plate.

PF Controllers BR4000-S Series

- Compact • Intelligent • User-friendly • Cost-effective

General

BR 4000-S series controller is a compact and most economical series of Power Factor controller. Its uniqueness lies in the simplicity of programming, as the controller is auto initialization i.e., user has to input only the CT ratio.

BR 4000-S Controller series is available in 4,6 and 8 Stages and is best suited for conventional APFC applications.



Features :

- 3 digit 7 Segment display
- Real-time cos phi
- Suitable for Inductive reactive power compensation
- Minimum user intervention Viz.
 - Auto CT polarity correction
 - Auto bank value detection
 - Auto number of connected bank
- Versatile capacitor bank input methods
 - Direct capacitor bank KVAR
 - Auto detected capacitor bank KVAR
 - Control series

- Low voltage, high voltage, under-current
- Fault detection and bank protection
- Intelligent bank control for optimum bank utilization
- 4 / 6 / 8 relay configuration
- Minimum system settings in auto mode
- User configurable connections, disconnection, discharge times.

Technical Data :

- Measurement Voltage : 80...300 VAC, 240 V nominal
- Current input selectable : 1A or 5A
- Auxiliary supply Voltage : 80...300 VAC
- Steps : 4, 6 and 8 relay outputs
- Minimum operating Current : 10 mA.

Typical wiring diagram :

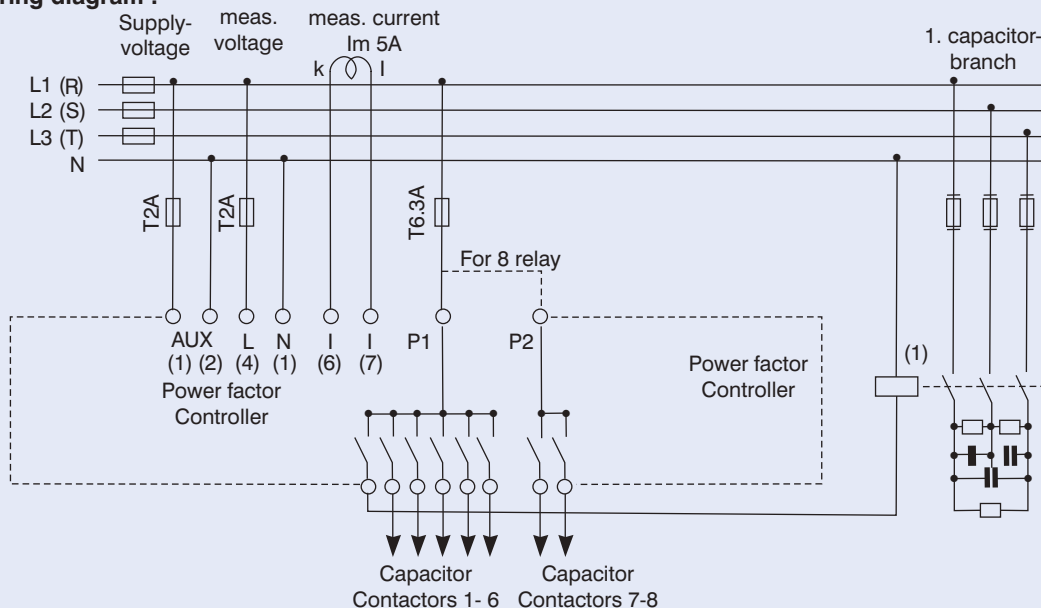

PF Controllers BR4000-S Series

● Compact ● Intelligent ● User-friendly ● Cost-effective

Technical data	BR4000S
Series Type Steps	B44066R41..R240
Steps	4,6 and 8 relay output
Supply Voltage	80....300V (L-N)
Measurement Voltage	80....300V (L-N)
Frequency	50 Hz
Switching	Contactors
Operating Temperature	0°C to 55°C
Load CT Input Current	X/5A
Target Cos phi	Fixed to 0.99 Inductive
System Parameter displayed	
System Voltage (V AC)	No
Reactive Power (KVAR)	No
Active power (kW)	No
Apparent Power (KVA)	No
Line Current (A)	No
Real-time Cos Phi	Yes
Temperature (°C)	No
Difference to PF	No
THD-V / THD - I in %	No
Individual Harmonics in % up to 31st for V and I	No
Energy kWh (Import/ Export)	No
Energy KVAh	No
Energy KVARh (Inductive / Capacitive) Demand KVA/current	No
Demand KVA / current	No
Run Hour - Number of hours load is connected	No
On Hour - hours for which power supply is On	No
Number of interruption of power supply	No
Alarm Relay	
Out of Bank (Under Compensation)	No
Overcompensation	No
Under Voltage	No
Over Voltage	No
Undercurrent	No
Overcurrent	No
Over temperature	No
Under/ Over Frequency	No
Excess Harmonics (V-THD / I-THD)	No
Recall recorded values	
Maximum / Minimum Voltage	No
Maximum / Minimum current	No
Maximum / Minimum Frequency	No
Maximum / Minimum Active power	No
Maximum / Minimum Apparent power	No
Maximum / Minimum Reactive power	No
Maximum / Minimum temperature	No
Maximum / Minimum THD (V/I)	No
Switching count of Capacitor	No
Operation time of Capacitor	No
Switching On and Off	5 to 999 Sec
Discharge Time	10 to 999 Sec
Dimension	96 X 96 X 35 mm.

PF Controllers BR2100 Series

- Intelligent • User-friendly • Cost-effective

General

BR 2100 controller is an intelligent, auto initialization Series of Power Factor controller. They measure the actual power factor and connect or disconnect Capacitor stages to achieve the desired power factor. The PF Controller series offers highly intelligent control behavior helps programming in auto, User Defined and control series mode simplifies installation, handling and Maintenance.



Features :

- Display
- Large and multifunctional LCD (2 x16 characters)
- Graphic and alphanumeric LCD illumination
- Intelligent control
- Menu driven handling in English language
- Test-run possible
- Large voltage measuring range
- Recall function of recorded values
- Four-quadrant operation
- Potential free contact alarm output (optional)
- RS485 communication interface (optional)

- Real Time Clock (Optional)
- Log of Time date stamping for last 3 system faults enabled
- Auto Initialization function
 - Input voltage connection detection (L-N/L-L)
 - Input Phase correction angle detection
 - Number of capacitor bank connected
- Three bank selection mode
 - Control series (Upto 20)
 - User defined capacitor bank KVAR
 - Auto detected capacitor bank KVAR.

Technical data :

- Measurement Voltage : 30... 550 VAC (L-L/L-N)
- Current input selectable : X1A or 5A On site Programmable
- Auxiliary supply Voltage : 110 V... 550 VAC
- Steps : 6 / 8 / 12
- Minimum operating Current : 2 mA.

Typical wiring diagram :

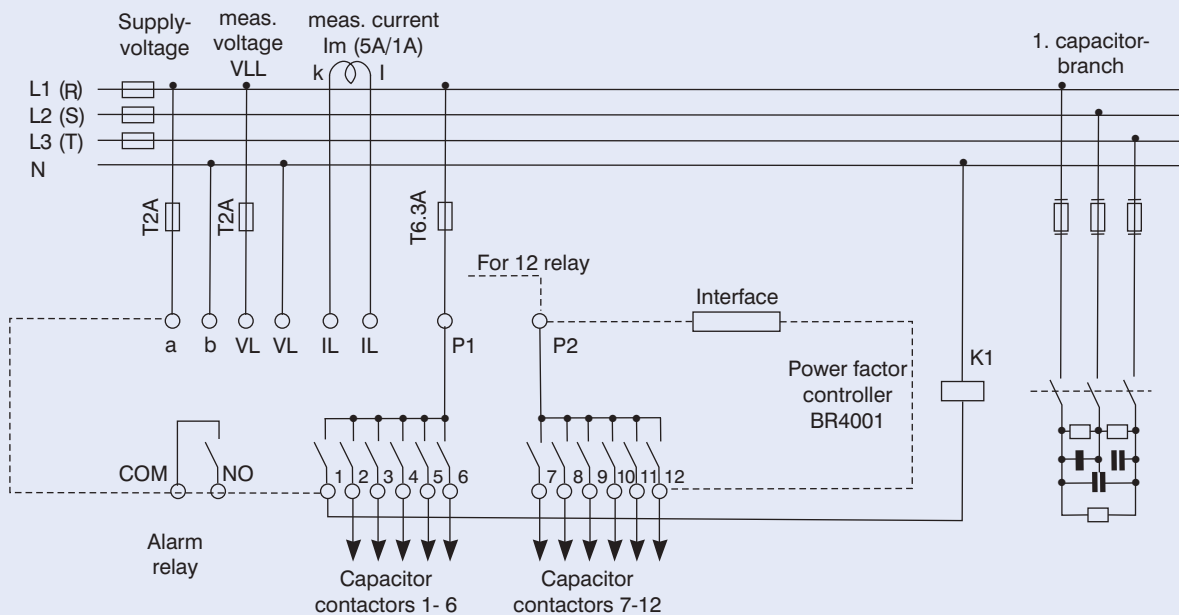

PF Controllers BR2100 Series

- Intelligent ● User-friendly ● Cost-effective

Technical data	BR2100
Series Type	B44066R2...R240
Steps	6,8 and 12 relay output
Supply Voltage	110....550 VAC
Measurement Voltage	30....550 VAC
Frequency	40 to 70 Hz
Switching	Contactator
Operating Temperature	-10°C to +60°C
Load CT input Current	X/5A & X/1A onsite programmable
Target Cosphi	0.8 Inductive to 0.8 Capacitive
System Parameter displayed	
System voltage (V AC)	Yes
Reactive power (KVAR)	Yes
Active power (kW) Apparent power (KVA)	Yes
Apparent power (KVA)	Yes
Line current (A)	Yes
Temperature (°C)	Yes
Real-time cosphi	Yes
Difference to PF	Yes
THD -V/ THD -I in%	Yes
Individual Harmonics in % up to 31st for V and I	Yes
Energy kWh (Import/ Export)	Yes
Energy KVAh	Yes
Energy KVARh (Inductive / Capacitive)	Yes
Demand KVA/current	Yes
Run Hour - Number of hours load is connected	Yes
On Hour - hours for which power supply is On	Yes
Number of interruption of power supply	Yes
Alarm Relay	
Out of Bank (Under Compensation) Overcompensation	Yes
Overcompensation	Yes
Under Voltage	Yes
Over Voltage	Yes
Undercurrent	Yes
Overcurrent	Yes
Over temperature	Yes
Under / Over Frequency	Yes
Excess Harmonics (V-THD / I-THD)	Yes
Recall recorded values	
Maximum / Minimum Voltage	Yes
Maximum / Minimum current	Yes
Maximum / Minimum Frequency	Yes
Maximum / Minimum Active power	Yes
Maximum / Minimum Apparent power	Yes
Maximum / Minimum Reactive power	Yes
Maximum / Minimum temperature	Yes
Maximum / Minimum THD (V/I)	Yes
Switching count of Capacitor	Yes
Operation time of Capacitor	Yes
Switching On and Off	10 Sec to 30 Min
Discharge Time	60 Sec to 30 Min
Dimension	144 X 144 X 56mm
Weight	0.57kg

Switching Devices - Capacitor Duty Contactors

Soft Switching of Capacitor • Excellent Damping of Inrush • Improved Power Quality • UL Certified

General

When a capacitor is switched to an AC voltage, the result is a resonant circuit damped to a greater or lesser degree. The switching of capacitors can cause high inrush currents, particularly when they are switched in parallel to others already activated in the power line, and if high short-circuit powers are present on the line.

Capacitor contactors with damping resistors make use of pre-switching auxiliary contacts. They close before the main contacts and pre-load the capacitor thus avoiding current peak values.

This influences positively the life expectancy of the capacitor significantly in addition to the positive impact on the power quality (avoiding transients and voltage sags that otherwise may be caused by switching in capacitors).

The capacitor duty contactors are offered in two versions, viz

- Standard series
- Premium series (imported).

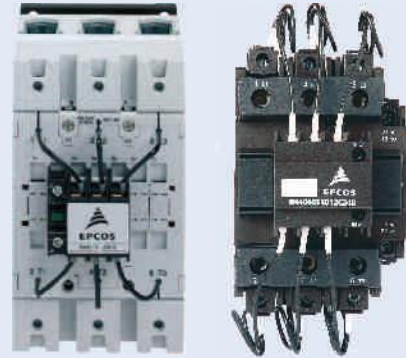

Applications

- Damping of inrush current in low-voltage PFC systems
- For PFC systems with and without reactors.

Features

- Excellent damping of inrush current
- Improved power quality (e.g. avoidance of voltage sags)
- Longer useful service life of main contacts of capacitor contactor
- Soft switching of capacitor and thus longer useful service life
- Enhanced mean life expectancy of PFC system
- Reduced ohmic losses
- Leading contacts with wiper function
- Tamper-proof and protected resistors
- Easy access for cable connection
- Voltage range: 400...690 V
- Output range: 12.5...100 KVAR
- Series J230 / C240 for all PFC systems
- AC6b utilization category.

Approvals

- UL file E224924 NLDX and NLDX 7 for J series
- UL file E334934 NLDX and NLDX 7 for C series.

Switching Devices - Capacitor Duty Contactors

Soft Switching of Capacitor • Excellent Damping of Inrush • Improved Power Quality • UL Certified

Technical data : Capacitor duty contactors premium series

Type		B44066****J230							
Main contacts		S1811	S2411	S3211	S5011	S6211	S7411	S9011	S9911
Rated insulation voltage V_i, V_{is}	[V AC]	690 ¹⁾	690 ¹⁾	690 ¹⁾	690 ¹⁾	690 ¹⁾	690 ¹⁾	1,000 ¹⁾	1,000 ¹⁾
Admissible frequency of operation	1/h	120	120	120	120	120	80	80	80
Contact life	million operations	0.25	0.15	0.15	0.15	0.15	0.12	0.12	0.12
Cable cross section									
Solid or standard	[mm ²]	1.5–6	2.5–25	2.5–25	4–50	4–50	4–50	0.5–95/10–120	0.5–95/10–120
Flexible	[mm ²]	1.5–4	2.5–16	2.5–16	10–35	10–35	10–35	0.5–70/10–95	0.5–70/10–95
Flexible with multicore cable end	[mm ²]	1.5–4	2.5–16	2.5–16	6–35	6–35	6–35	0.5–70/10–95	0.5–70/10–95
Cables per clamp		2	1	1	1	1	1	2	2
Operating range of V_s magnet coils in multiples of control voltage		0.85–1.1	0.85–1.1	0.85–1.1	0.85–1.1	0.85–1.1	0.85–1.1	0.85–1.1	0.85–1.1
Auxiliary contacts ¹⁾									
Rated insulation voltage V_i, V_{is}	[V AC]	690 ¹⁾	690 ¹⁾	690 ¹⁾	690 ¹⁾	690 ¹⁾	690 ¹⁾	690 ¹⁾	690 ¹⁾
Rated current I_n at ambient temperature									
max. 40°C	I_{coth} [A]	16	10	10	10	10	10	10	10
max. 60°C	I_{coth} [A]	12	6	6	6	6	6	6	6
Utilization category AC15									
220 to 240 V	I_{coth} [A]	12	3	3	3	3	3	3	3
380 to 440 V	I_{coth} [A]	4	2	2	2	2	2	2	2
Short circuit protection									
Highest fuse rating slow, gL (gG)	I_{coth} [A]	25	20	20	20	20	20	20	20
Auxiliary contacts	NO/NC	1/1	1/1	1/1	1/1	1/1	1/1	1/1	1/1

IEC 947-4-1, IEC 947-5-1, EN 60947-4-1, EN 60947-5-1, VDE 0660 Dimensional drawing: see datasheet

1) Applies to networks with grounded star point, overvoltage category I to IV, pollution severity 3 (industrial standard), $V_{imp} = 8$ kV. Values for other conditions on request.

Main technical parameters 230V coil:

Capacitor power at ambient temperature, voltage, 50/60 Hz						Rated current		Weight	Ordering code
380 – 400 V		415 – 440 V		660 – 690 V		50°C	60°C		
50°C	60°C	50°C	60°C	50°C	60°C	A	A	kg	
KVAr	KVAr	KVAr	KVAr	KVAr	KVAr				
0–12.5	0–12.5	0–13	0–13	0–20	0–20	18	18	0.34	B44066S1811J230
10–20	10–20	10.5–22	10.5–22	17–33	17–33	28	28	0.60	B44066S2411J230
10–25	10–25	10.5–27	10.5–27	17–41	17–41	36	36	0.60	B44066S3211J230
20–33.3	20–33.3	23–36	23–36	36–55	36–55	48	48	1.10	B44066S5011J230
20–50	20–50	23–53	23–53	36–82	36–82	72	72	1.10	B44066S6211J230
20–75	20–60	23–75	23–64	36–120	36–100	108	87	1.10	B44066S7411J230
33–80	33–75	36–82	36–77	57–120	57–120	115	108	2.30	B44066S9011J230*
33–100	33–90	36–103	36–93	57–148	57–148	144	130	2.30	B44066S9911J230*

* without CCC

Connection diagram

All types B44066S****J230
(with preload resistors),
B44066S1811J230 with wires on the bottom,
B44066S9911J230 with resistors inside housing.

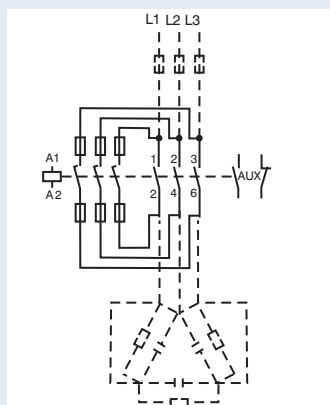

Switching Devices - Capacitor Duty Contactors

Soft Switching of Capacitor • Excellent Damping of Inrush • Improved Power Quality • UL Certified

Technical data : Capacitor duty contactors standard series

Type	B44066****C240								
Main contacts		C1011	C1211	C1611	C2011	C2511	C3312	C4012	C6012
Rated insulation voltage V_i V_{is}	[V AC]	690 ¹⁾	690 ¹⁾	690 ¹⁾	690 ¹⁾	690 ¹⁾	690 ¹⁾	690 ¹⁾	690 ¹⁾
Admissible frequency of operation	1/h	240	240	240	240	240	240	240	100
Contact life	million operations	0.2	0.2	0.2	0.1	0.1	0.1	0.1	0.1
Cable cross section									
Flexible with cable end sleeve - 1 conductor	[mm ²]	2.5	2.5	4	4	6	16	16	50
Flexible with cable end sleeve - 2 conductors	[mm ²]	1.5	1.5	2.5	4	4	6	6	25
Solid without cable end sleeve - 1 conductor	[mm ²]	4	4	6	10	16	25	25	50
Solid without cable end sleeve - 2 conductors	[mm ²]	4	4	6	6	10	16	16	35
Operating range of magnet coils in multiples of control voltage V_s		0.78-1.1	0.78-1.1	0.78-1.1	0.78-1.1	0.78-1.1	0.78-1.1	0.78-1.1	0.78-1.1
Auxiliary contacts ¹⁾									
Rated insulation voltage V_i V_{is}	[V AC]	690 ¹⁾	690 ¹⁾	690 ¹⁾	690 ¹⁾	690 ¹⁾	690 ¹⁾	690 ¹⁾	690 ¹⁾
Rated current I_{in} at ambient temperature:									
40° C	I_{coth} [A]	10	10	10	10	10	10	10	10
60° C	I_{coth} [A]	8	8	8	8	8	8	8	8
Utilization category AC15									
220 ... 240 V	I_{coth} [A]	3	3	3	3	3	3	3	3
380 ... 440 V	I_{coth} [A]	1.5	1.5	1.5	1.5	1.5	1.5	1.5	1.5
Short circuit protection	I_{coth} [A]	10	10	10	10	10	10	10	10
Highest fuse size, slow, gL (gG)									
Auxiliary contacts									
NO		1	1	1	1	1	1	1	1
NC		1	1	1	1	1	2	2	2

IEC 947-4-1, IEC 947-5-1, EN 60947-4-1, EN 60947-5-1, VDE 0660 Dimensional drawing: see datasheet

1) Applies to networks with grounded star point, overvoltage category I to IV, pollution severity 3 (industrial standard), $V_{imp} = 8$ kV. Values for other conditions on request.

Main technical parameters 240 V coil:

Capacitor power at ambient temperature, voltage, 50 / 60 Hz		Rated current		Weight	Ordering code
380 - 400 V	415 - 440 V 660 - 690 V				
55 °C	55 °C	55 °C	55 °C		
KVAr	KVAr	KVAr	A	kg	
0-10	0-10	0-12.5	14	0.43	B44066S1011C240
0-12.5	0-12.5	0-18	18	0.43	B44066S1211C240
0-16.7	0-16.7	0-24	24	0.43	B44066S1611C240
0-20	0-20	0-30	29	0.43	B44066S2011C240
0-25	0-25	0-36	36	0.43	B44066S2511C240
0-33.3	0-33.3	0-48	48	0.43	B44066S3312C240
0-40	0-40	0-58	58	0.43	B44066S4012C240
0-60	0-60	0-92	92	0.43	B44066S6012C240

Connection diagrams

Types B44066S...1C240

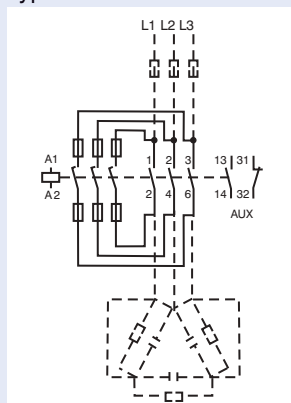

Types B44066S...2C240

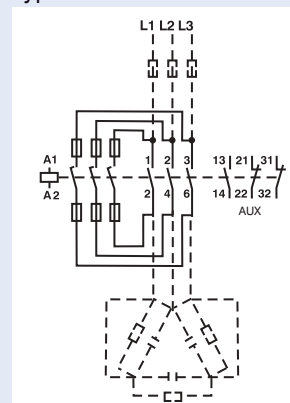

Switching Devices - Thyristor Modules for Dynamic PFC TSM Series

Ultrafast Smooth Switching • Natural Cooled • Compact Design • Enhanced Life of System

General

Conventional systems for power factor correction are used to optimize the power factor and reduce the level of harmonics in the grid. The usage of new technologies in modern industry has negative impacts on electric power quality of the main supply networks, e.g. frequent high load fluctuations and harmonic oscillation.

Excessive currents, increased losses and flickering will not only influence the supply capacity but will also have a significant impact on the operation of sensitive electronic devices.

The solution for this are dynamic power factor correction systems. With the thyristor module series TSM-LCN and TSM-HV, we provide the main component – “the electronic switch” – for dynamic power factor correction.

The TSM module series offers fast electronically controlled, self-observing thyristor switches for capacitive loads up to 50 KVAR, that are capable to switch PFC capacitors within a few milliseconds nearly without a limitation to the number of switchings during the capacitor lifetime.



Applications :

- Main supply networks with high load fluctuations for dynamic PFC systems
- Presses
- Welding machines
- Elevators
- Cranes
- Wind turbines.

Features :

- Easy installation: it can be used similar to a contactor
- All the intelligence needed is offered within the thyristor module itself
- Reaction time: 5 milliseconds only
Permanent self-controlling of:
 - voltage parameter
 - phase sequence
 - capacitor output
- Display of
 - operation
 - faults
 - activation
- Voltage range: 440 V and 690 V
Output range:
 - 440 V: 10, 25 and 50 KVAR
 - 690 V: 50 KVAR.

Switching Devices - Thyristor Modules for Dynamic PFC TSM Series

Ultrafast Smooth Switching • Natural Cooled • Compact Design • Enhanced Life of System

Dynamic PFC network BR5000-T multiple stages

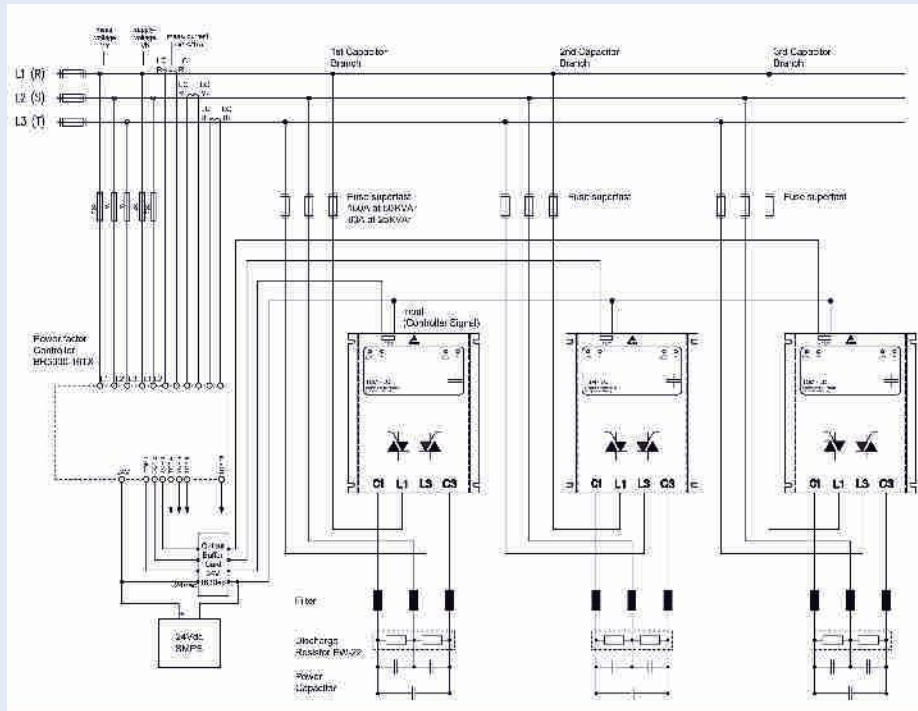

Dynamic PFC network BR6000-T multiple stages

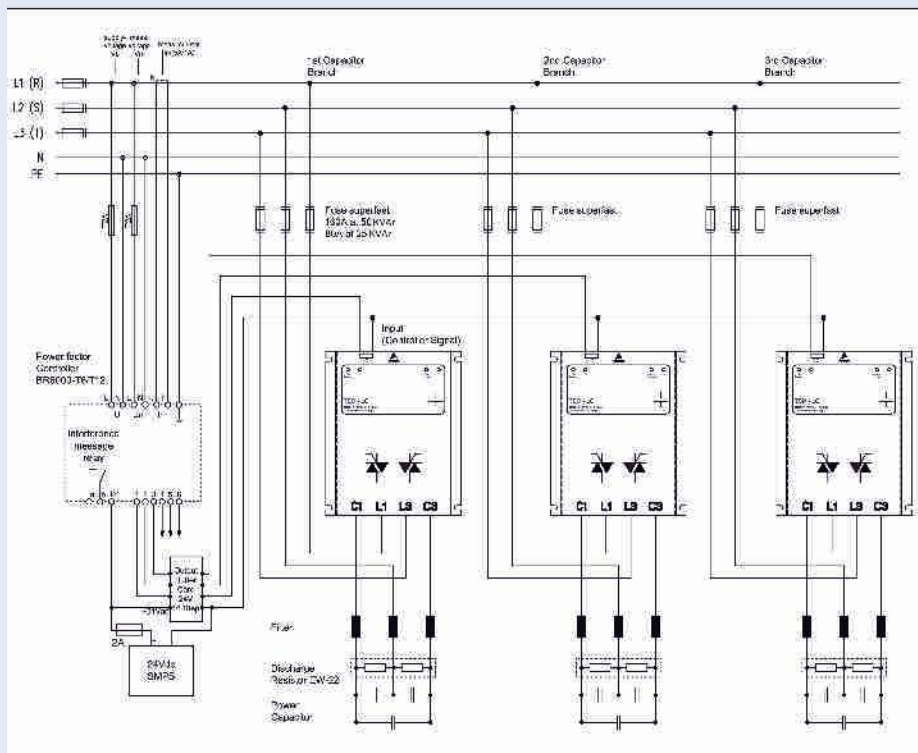

Switching Devices - Thyristor Modules for Dynamic PFC TSM Series

Ultrafast Smooth Switching • Natural Cooled • Compact Design • Enhanced Life of System

Selection table TSM series				
	TSM-LC 10	TSM-LCN 25	TSM-LCN 50	TSM-HV 50
Ordering code	B44066T0010R440	B44066T3025R442	B44066T3050R442	B44066T0050R690
Rated voltage	380 ... 440 V	380 ... 440 V	380 ... 440 V	690 V
Max. grid voltage: – in conventional PFC systems (without reactors)	440 V	440 V	440 V	690 V
– in detuned PFC system (7% detuning)	440 V (no upwards tolerance)	440 V (no upwards tolerance)	440 V (no upwards tolerance)	690 V
– in detuned PFC system (14% detuning)	400 V	400 V	400 V	690 V
Frequency	50/60 Hz	50/60 Hz	50/60 Hz	50/60 Hz
Maximum power / at nominal voltage	10 KVA	25 KVA	50 KVA	50 KVA
Power circuit	Direct connection 4 pole via terminal clamps (D = 6 mm ² resp. 4 mm ²)	Direct connection (cable lug 35mm ²)	Direct connection (cable lug 35mm ²)	Direct connection 4 pole via busbar (cable lug 25mm ² D = 8 mm)
Neutral required	No*	No*	No*	Yes**
Aux. supply voltage required	No	No	No	230 V AC
Connection	from bottom	from bottom	from bottom	from bottom
Losses (PD in W)	2.0 x I (in A) typical; 35 W (thermal)	2.0 x I (in A) typical; 75 W (thermal)	2.0 x I (in A) typical; 150 W (thermal)	3.0 x I (in A) typical; at 690 V/ 50 KVA approx. 125 W (thermal)
Recommended fuses "superfast"	3 x BS Type (AC 690 V) 40 A	3 x BS Type (AC 690 V) 80 A	3 x BS Type (AC 690 V) 160 A	3 x BS Type (AC 690 V)
Dimensions in mm (w x h x d)	163 x 150 x 75	157 x 200 x 180	157 x 200 x 180	157 x 200 x 195
Weight	1.75 kg	4.8 kg	4.8 kg	5 kg
LED display per phase	2	2	2	1
Cascading	yes	yes	yes	yes
Ambient temperature	-10 °C ... 55 °C	-10 °C ... 55 °C	-10 °C ... 55 °C	-10 °C ... 55 °C
Discharge resistors EW-22 needed	1	1	1	Standard resistor sufficient
Three phase current limitation reactor needed***	1	1	1	1.

*For operation with three-phase capacitor or three single-phase capacitors. **Only for and compulsorily for operation with single-phase capacitors. ***For PFC systems without detuning reactors mandatory.

Accessories for TSM-LCN modules

Type/Description

Discharge resistors EW-22 at least 1 piece per step to be used for all types of TSM-LCN if fast re-switching time is required. For higher rated steps please contact your local sales office.

Ordering Code

B44066T0022S400

EW-22:

Dimensions (w x d x h) : 90 x 50 x 100 mm
 Weight (approx.) : 0.3 kg
 Design panel : for mounting on heat sink/fitting
 Connection : wago terminal, ready for three-phase connection to the capacitor.

Note :

Three phase current limitation reactor for thyristor modules TSM-series in conventional dynamic PFC-systems without reactor is a must Used for limitation of the pace of current increase di/dT in the thyristors to the maximum permissible value.



Buffer Card

Current amplifier for TSM application • Short circuit protected

Output Buffer card

Features

- Transistorised output for fast switching
- Short circuit protection for outputs
- Standard DIN rail mount design provides for easy mounting.

Technical data

Input signal	24 VDC \pm 3V, 15mA
Output voltage	Maximum 1V drop on input signal
Output current	100mA max.
Output type	Transistor output
Number of inputs	16
Number of outputs	16
Temperature range	0°C to 60°C
Mounting	Din Rail mounting
Dimensions (L x W x H)	72 x 125 x 125 mm
Total weight (kg)	0.4 kg (approx).



Dimensions and connection

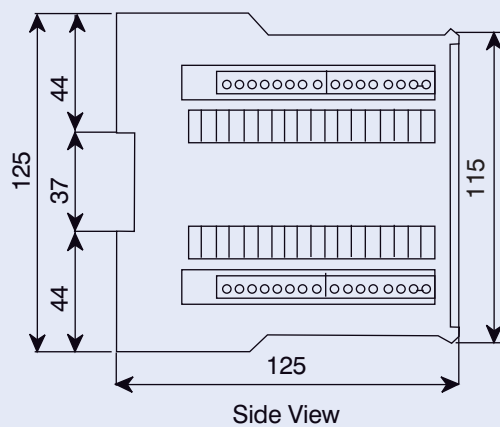
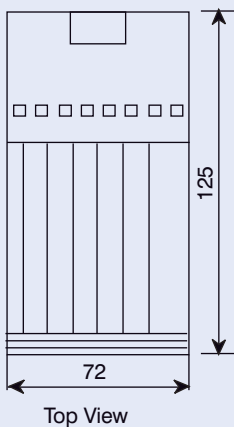
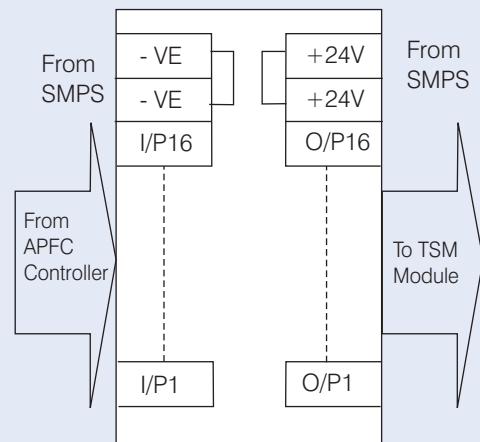
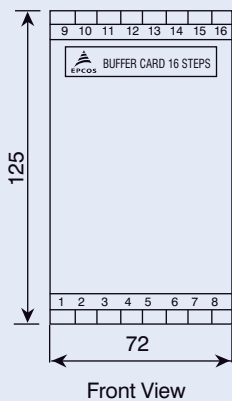

Reactors - Antiresonance Harmonic Filter

Type tested at CPRI • 'H' Class insulation • Thermal Micro Switch • Linearity $\geq 173\%$

General

The increasing use of modern power electronic apparatus (drives, uninterruptible power supplies, etc.) produces nonlinear current and thus influences and loads the network with harmonics (line pollution).

The power factor correction or capacitance of the power capacitor forms a resonant circuit in conjunction with the feeding transformer. Experience shows that the self-resonant frequency of this circuit is typically between 250 and 500 Hz, i.e. in the region of the 5th and 7th harmonics.

Such a resonance although can lead to the following undesirable effects:

- overloading of capacitors,
- overloading of transformers and transmission equipment,
- interference with metering and control systems, computers and electrical gear,
- resonance elevation, i.e. amplification of harmonics,
- voltage distortion.

These resonance phenomena can be avoided by connecting capacitors in series with filter reactors in the PFC system. These so called "detuned" PFC systems are scaled in a way that the self-resonant

frequency is below the lowest line harmonic. The detuned PFC system is purely inductive seen by harmonics above this frequency. For the base line frequency (50 or 60 Hz usually), the detuned system on the other hand acts purely capacitive, thus correcting the reactive power.



Applications

- Avoidance of resonance conditions
- Tuned and detuned harmonic filters
- Reduction of harmonic distortion (network clearing)
- Reduction of power losses.

Features

- High harmonic loading capability
- Very low losses
- High linearity to avoid choke tilt
- Low noise
- Convenient mounting
- Long expected life time
- Temperature protection (NC contact).

Technical data and limit values

Filter reactors	
Harmonics*	$V_3 = 0.5\% V_R$ (duty cycle = 100%) $V_5 = 6.0\% V_R$ (duty cycle = 100%) $V_7 = 5.0\% V_R$ (duty cycle = 100%) $V_{11} = 3.5\% V_R$ (duty cycle = 100%) $V_{13} = 3.0\% V_R$ (duty cycle = 100%)
Effective current	$I_{rms} = \sqrt{(I_1^2 + I_3^2 + \dots + I_{13}^2)}$
Fundamental current	$I_1 = 1.06 \cdot I_R$ (50 Hz or 60 Hz current of capacitor)
Temperature protection	microswitch (NC)
Dimensional drawings and terminals	see page 60 and 61

Three-phase filter reactors to EN 60289

Frequency	50 Hz or 60 Hz
Voltage	400, 415, 440, 690*#
Output	5 ... 100 KVar
Detuning	5.67%, 7%, 14%
Cooling	natural
Ambient temperature	40°C
Class of insulation	H
Enclosure	IP00.

* According to DIN ENV W61000-2-2.

Other voltage ratings on request.

Reactors - Antiresonance Harmonic Filter

Type tested at CPRI • 'H' Class insulation • Thermal Micro Switch • Linearity $\geq 173\%$

Rated voltage - 440 V 7% aluminum wound reactors

Electrical Parameters and Terminations					
KVAr	Material Code	Rated Current (A)	I rms (A)	Inductance (mH)	Terminations
5	B44066D7005K440N1	6.6	7.45	9.28	CU. 6/6 Sq. mm
10	B44066D7010K440N1	13.2	14.9	4.65	CU. 6/6 Sq. mm
12.5	B44066D7012K440N1	16.5	18.7	3.71	CU. 6/6 Sq. mm
15	B44066D7015K440N1	19.65	22.35	3.1	AL. 8/35 Sq. mm
20	B44066D7020K440N1	26.24	29.78	2.32	AL. 8/35 Sq. mm
25	B44066D7025K440N1	32.8	37.2	1.86	AL. 8/35 Sq. mm
30	B44066D7030K440N1	39.36	44.7	1.55	AL. 8/50 Sq. mm
40	B44066D7040K440N1	52.49	59.6	1.16	AL. 8/50 Sq. mm
50	B44066D7050K440N1	65.61	74.5	0.93	AL. 8/50 Sq. mm
75	B44066D7075E440N1	98.41	111.68	0.62	20X3 CU BUSBAR
100	B44066D7100E440N1	131.22	148.91	0.46	25X3 CU BUSBAR

Rated voltage - 415 V 7% aluminum wound reactors

Electrical Parameters and Terminations					
KVAr	Material Code	Rated Current (A)	I rms (A)	Inductance (mH)	Terminations
5	B44066D7005K415N1	6.96	7.89	8.257	CU. 6/6 Sq. mm
10	B44066D7010K415N1	13.91	15.79	4.128	CU. 6/6 Sq. mm
12.5	B44066D7012K415N1	17.39	19.73	3.303	CU. 6/6 Sq. mm
15	B44066D7015K415N1	20.87	23.68	2.752	AL. 8/35 Sq. mm
20	B44066D7020K415N1	27.82	31.58	2.064	AL. 8/35 Sq. mm
25	B44066D7025K415N1	34.78	39.47	1.651	AL. 8/35 Sq. mm
30	B44066D7030K415N1	41.74	47.36	1.376	AL. 8/50 Sq. mm
40	B44066D7040K415N1	55.65	63.15	1.032	AL. 8/50 Sq. mm
50	B44066D7050K415N1	69.56	78.94	0.826	AL. 8/50 Sq. mm
75	B44066D7075E415N1	104.34	118.41	0.55	20x3 CU BUSBAR
100	B44066D7100E415N1	139.12	157.88	0.413	25x3 CU BUSBAR

Reactor dimensional details

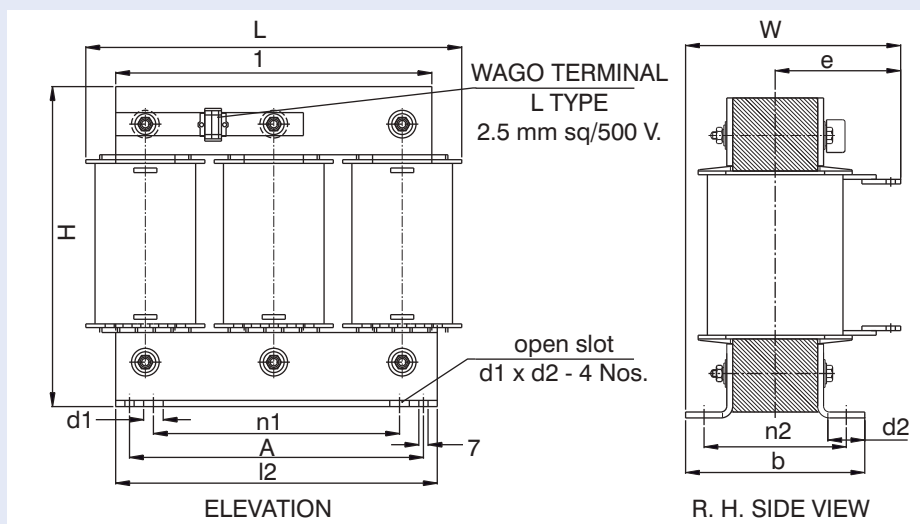

Reactors - Antiresonance Harmonic Filter

Type tested at CPRI • 'H' Class insulation • Thermal Micro Switch • Linearity $\geq 173\%$

Rated voltage - 440 V 7% aluminum wound reactors

Dimensions														
KVAr	Material Code	L	W	H	l1	l2	n1	n2	b	e	d1	d2	A	B
5	B44066D7005K440N1	175	95 ± 5	158	150	150	100	56 ± 3	73	60 ± 5	10.8	15.5	125	56
10	B44066D7010K440N1	175	124 ± 5	160	150	150	100	78 ± 3	95	75 ± 5	10.8	15.5	125	78
12.5	B44066D7012K440N1	175	124 ± 5	160	150	150	100	78 ± 3	95	75 ± 5	10.8	15.5	125	78
15	B44066D7015K440N1	225	150 ± 5	230	190	190	150	73 ± 3	93	105 ± 5	10.8	15.5	180	73
20	B44066D7020K440N1	225	165 ± 5	205	190	190	150	95 ± 3	114	115 ± 5	10.8	15.5	180	95
25	B44066D7025K440N1	225	165 ± 5	205	190	190	150	95 ± 3	114	115 ± 5	10.8	15.5	180	95
30	B44066D7030K440N1	260	225 ± 5	240	220	220	150	165 ± 3	185	127 ± 5	10.8	15.5	175	165
40	B44066D7040K440N1	260	225 ± 5	240	220	220	150	165 ± 3	185	127 ± 5	10.8	15.5	175	165
50	B44066D7050K440N1	260	225 ± 5	240	220	220	150	165 ± 3	185	127 ± 5	10.8	15.5	175	165
75	B44066D7075E440N1	310	180 ± 5	270	265	265	150	132 ± 3	150	97 ± 5	10.8	15.5	175	132
100	B44066D7100E440N1	330	180 ± 5	270	285	285	150	132 ± 3	155	97 ± 5	10.8	15.5	175	132

* All dimensions are in mm.

Rated voltage - 415V 7% aluminum wound reactors

Dimensions														
KVAr	Material code	L	W	H	l1	l2	n1	n2	b	e	d1	d2	A	B
5	B44066D7005K415N1	175	95 ± 5	158	150	150	100	56 ± 3	73	60 ± 5	10.8	15.5	125	56
10	B44066D7010K415N1	175	124 ± 5	160	150	150	100	78 ± 3	95	75 ± 5	10.8	15.5	125	78
12.5	B44066D7012K415N1	175	124 ± 5	160	150	150	100	78 ± 3	95	75 ± 5	10.8	15.5	125	78
15	B44066D7015K415N1	225	150 ± 5	230	190	190	150	73 ± 3	93	105 ± 5	10.8	15.5	180	73
20	B44066D7020K415N1	225	165 ± 5	205	190	190	150	95 ± 3	114	115 ± 5	10.8	15.5	180	95
25	B44066D7025K415N1	225	165 ± 5	205	190	190	150	95 ± 3	114	115 ± 5	10.8	15.5	180	95
30	B44066D7030K415N1	260	225 ± 5	240	220	220	150	165 ± 3	185	127 ± 5	10.8	15.5	175	165
40	B44066D7040K415N1	260	225 ± 5	240	220	220	150	165 ± 3	185	127 ± 5	10.8	15.5	175	165
50	B44066D7050K415N1	260	225 ± 5	240	220	220	150	165 ± 3	185	127 ± 5	10.8	15.5	175	165
75	B44066D7075E415N1	310	180 ± 5	270	265	265	150	132 ± 3	150	97 ± 5	10.8	15.5	175	132
100	44066BD7100E415N1	330	180 ± 5	270	285	285	150	132 ± 3	155	97 ± 5	10.8	15.5	175	132

* All dimensions are in mm.

Reactor dimensional details

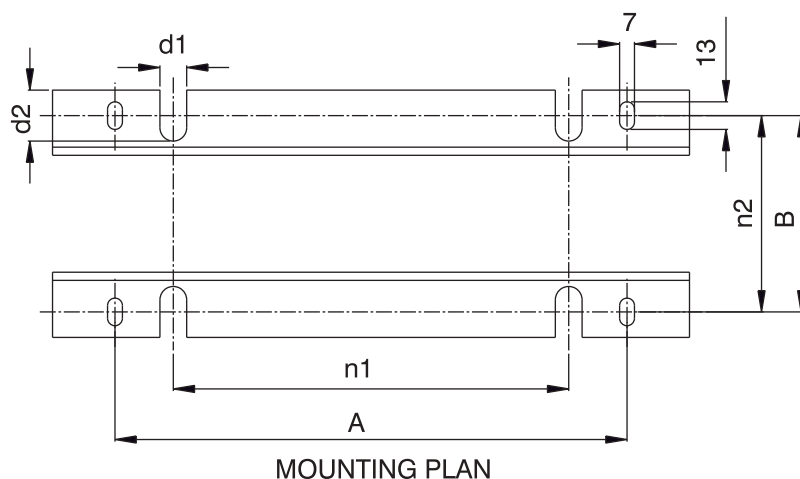

Detuned PFC: AL and CU COMBO codes for instant selection

7 % Detuning AL Reactor-Capacitor New PhaseCap Energy COMBO										
Step Rating	Voltage	Part	Reactor Rating	Reactor Voltage	Reactor Type	Capacitor Voltage	Capacitor Rating	Capacitor Bank	Capacitor Type	
5	440	B25171C 5D591	5	440	AL Strip 173%	480	6.3	6.3 x 1	PhaseCap Energy HD	
10	440	B25171C 10D591	10	440	AL Strip 173%	480	11	11 x 1	PhaseCap Energy HD	
12.5	440	B25171C 12D591	12.5	440	AL Strip 173%	480	13.8	13.8 x 1	PhaseCap Energy HD	
15	440	B25171C 15D591	15	440	AL Strip 173%	480	16.6	16.6 x 1	PhaseCap Energy HD	
20	440	B25171C 20D591	20	440	AL Strip 173%	480	22.1	22 x 1	PhaseCap Energy HD	
25	440	B25171C 25D591	25	440	AL Strip 173%	480	28.1	28.1 x 1	PhaseCap Energy HD	
50	440	B25171C 50D591	50	440	AL Strip 173%	480	56.2	28.1 x 2	PhaseCap Energy HD	
75	440	B25171C 75D594	75	440	AL Foil 173%	480	84.3	28.1 x 3	PhaseCap Energy HD	
100	440	B25171C 99D594	100	440	AL Foil 173%	480	112.4	28.1 x 4	PhaseCap Energy HD	
5	440	B25171C 5E591	5	440	AL Strip 173%	525	6.3	6.3 x 1	PhaseCap Energy HD	
10	440	B25171C 10E591	10	440	AL Strip 173%	525	13.2	13.2 x 1	PhaseCap Energy HD	
12.5	440	B25171C 12E591	12.5	440	AL Strip 173%	525	16.7	16.7 x 1	PhaseCap Energy HD	
15	440	B25171C 15E591	15	440	AL Strip 173%	525	20	20 x 1	PhaseCap Energy HD	
20	440	B25171C 20E591	20	440	AL Strip 173%	525	26.5	26.5 x 1	PhaseCap Energy HD	
25	440	B25171C 25E591	25	440	AL Strip 173%	525	33.1	33.1 x 1	PhaseCap Energy HD	
50	440	B25171C 50E591	50	440	AL Strip 173%	525	66.2	33.1 x 2	PhaseCap Energy HD	
75	440	B25171C 75E594	75	440	AL Foil 173%	525	99.3	33.1 x 3	PhaseCap Energy HD	
100	440	B25171C 99E594	100	440	AL Foil 173%	525	132.4	33.1 x 4	PhaseCap Energy HD	
7 % Detuning AL Reactor-Capacitor New PhaseCap SHD COMBO										
5	440	B25171C 5D582	5	440	AL Strip 173%	480	6.3	6.3 x 1	New PhaseCap SHD	
10	440	B25171C 10D582	10	440	AL Strip 173%	480	11	11 x 1	New PhaseCap SHD	
12.5	440	B25171C 12D582	12.5	440	AL Strip 173%	480	13.8	13.8 x 1	New PhaseCap SHD	
15	440	B25171C 15D582	15	440	AL Strip 173%	480	16.6	16.6 x 1	New PhaseCap SHD	
20	440	B25171C 20D582	20	440	AL Strip 173%	480	22	22 x 1	New PhaseCap SHD	
25	440	B25171C 25D582	25	440	AL Strip 173%	480	28.1	28.1 x 1	New PhaseCap SHD	
50	440	B25171C 50D582	50	440	AL Strip 173%	480	56.2	28.1 x 2	New PhaseCap SHD	
75	440	B25171C 75D581	75	440	AL Foil 173%	480	84.3	28.1 x 3	New PhaseCap SHD	
100	440	B25171C 99D585	100	440	AL Foil 173%	480	112.4	28.1 x 4	New PhaseCap SHD	
5	440	B25171C 5E582	5	440	AL Strip 173%	525	6.3	6.3 x 1	New PhaseCap SHD	
10	440	B25171C 10E582	10	440	AL Strip 173%	525	13.2	13.2 x 1	New PhaseCap SHD	
12.5	440	B25171C 12E581	12.5	440	AL Strip 173%	525	16.7	16.7 x 1	New PhaseCap SHD	
15	440	B25171C 15E582	15	440	AL Strip 173%	525	20	20 x 1	New PhaseCap SHD	
20	440	B25171C 20E582	20	440	AL Strip 173%	525	26.5	26.5 x 1	New PhaseCap SHD	
25	440	B25171C 25E583	25	440	AL Strip 173%	525	33.1	33.1 x 1	New PhaseCap SHD	
50	440	B25171C 50E583	50	440	AL Strip 173%	525	66.2	33.1 x 2	New PhaseCap SHD	
75	440	B25171C 75E583	75	440	AL Foil 173%	525	99.3	33.1 x 3	New PhaseCap SHD	
100	440	B25171C 99E586	100	440	AL Foil 173%	525	132.4	33.1 x 4	New PhaseCap SHD	
7 % Detuning CU Reactor-Capacitor New PhaseCap SHD COMBO										
5	440	B25171C 5D587	5	440	CU Strip 173%	480	6.3	6.3 x 1	New PhaseCap SHD	
10	440	B25171C 10D587	10	440	CU Strip 173%	480	11	11 x 1	New PhaseCap SHD	
12.5	440	B25171C 12D587	12.5	440	CU Strip 173%	480	13.8	13.8 x 1	New PhaseCap SHD	
15	440	B25171C 15D587	15	440	CU Strip 173%	480	16.6	16.6 x 1	New PhaseCap SHD	
20	440	B25171C 20D587	20	440	CU Strip 173%	480	22	22 x 1	New PhaseCap SHD	
25	440	B25171C 25D587	25	440	CU Strip 173%	480	28.1	28.1 x 1	New PhaseCap SHD	
50	440	B25171C 50D587	50	440	CU Strip 173%	480	56.2	28.1 x 2	New PhaseCap SHD	
75	440	B25171C 75D587	75	440	CU Strip 173%	480	84.3	28.1 x 3	New PhaseCap SHD	
100	440	B25171C 99D587	100	440	CU Strip 173%	480	112.4	28.1 x 4	New PhaseCap SHD	
5	440	B25171C 5E587	5	440	CU Strip 173%	525	6.3	6.3 x 1	New PhaseCap SHD	
10	440	B25171C 10E587	10	440	CU Strip 173%	525	13.2	13.2 x 1	New PhaseCap SHD	
12.5	440	B25171C 12E587	12.5	440	CU Strip 173%	525	16.7	16.7 x 1	New PhaseCap SHD	
15	440	B25171C 15E587	15	440	CU Strip 173%	525	20	20 x 1	New PhaseCap SHD	
20	440	B25171C 20E587	20	440	CU Strip 173%	525	26.5	26.5 x 1	New PhaseCap SHD	
25	440	B25171C 25E587	25	440	CU Strip 173%	525	33.1	33.1 x 1	New PhaseCap SHD	
50	440	B25171C 50E587	50	440	CU Strip 173%	525	66.2	33.1 x 2	New PhaseCap SHD	
75	440	B25171C 75E587	75	440	CU Strip 173%	525	99.3	33.1 x 3	New PhaseCap SHD	
100	440	B25171C 99E587	100	440	CU Strip 173%	525	132.4	33.1 x 4	New PhaseCap SHD	

PQSine

Active Harmonic Filter and Power Optimizer

General

The PQSine series is an active harmonic filter system designed to eliminate harmonic oscillations and consequently reduce costs. PQSine monitors the current signal and compensates the unwanted elements of the measured current. Thus, the filter ensures harmonic suppression independently of the

number of loads. It also corrects the power factor and load balancing, improving the system efficiency while reducing harmonic pollution.

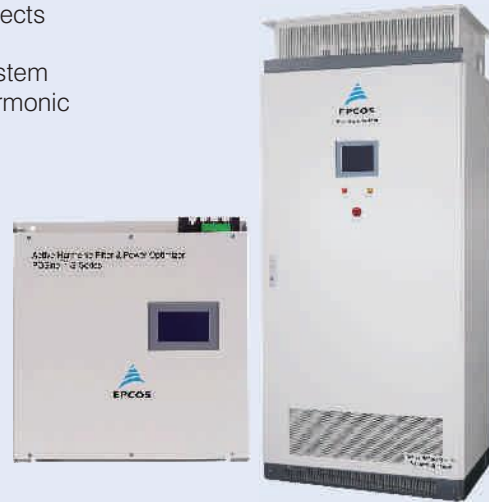

Features

- Harmonic compensation up to 50th harmonic (selectable)
- Flicker compensation
- Ultra-fast reactive power compensation (inductive and capacitive)
- Load balancing between phases and unloaded neutral wire
- Compact design
- Grid resonance detection
- Ethernet and Ethercat system for interconnection
- User-friendly menu operation
- High performance and reliability
- Insensitive to network conditions
- Simple installation
- True 4 Wire System
- Modular extendable System with modules ranging from 25A to 150A.

Applications

Fast current harmonics and reactive power suppression e.g. for:

- Data centers
- UPS systems
- Green power generation (e.g. photovoltaics and wind turbines)
- Sensitive equipment manufacturing (e.g. silicon wafer production, semiconductor production)
- Industrial production machines
- Electrical welding systems
- Plastic industry machinery (extruders, injection molders)
- Office buildings and shopping centers (3rd and triple harmonic cancellation and neutral conductor unloading).

Safety features

- Highest safety and reliability
- Overload protection
- Internal short-circuit protection
- Overheating protection
- Overvoltage and undervoltage protection
- Inverter bridge protection
- Resonance protection.

Active Harmonic Filters and Power Optimizers PQSine S-Series

The cleaner your grid, the higher your benefit
TDK active harmonic filters and power optimizers help to eliminate harmonic pollution from the grid, reduce power quality problems and use energy more efficiently and reliably.

Harmonic pollution is a growing problem with the increasing use of power electronics and non-linear loads (such as variable speed drives, UPS, computers, servers, TV sets, etc.).

The presence of harmonics increases the RMS current in power networks. The circulation of harmonic currents through the system impedance creates voltage harmonics which produce voltage distortions and thus deteriorate the quality of the supply voltage. This leads to higher operating and energy costs, production/process downtimes, overheating and malfunction of equipment.

The active harmonic filters PQSine S-Series from EPCOS are based on the latest state of the art in power electronics technology. They are installed in parallel to the polluting loads. The active filter analyzes the line current and its associated harmonics and generates a compensation current which neutralizes the harmonic currents and creates an almost sinusoidal waveform (see Figure 1). Figure 2 shows the total current harmonic distortion without AHF PQSine S-Series. Figure 3 shows the result with activated AHF PQSine S-Series, namely a cleaner grid. In addition to eliminating the harmonics, the AHF PQSine S-Series active filter and power optimizer also actively balances the loads to all three phases, performs dynamic VAR compensation and even some transient compensation. These features avoid line resonance and ensure high performance and reliability.

Active harmonic filter

Figure 1: Principle of active filter

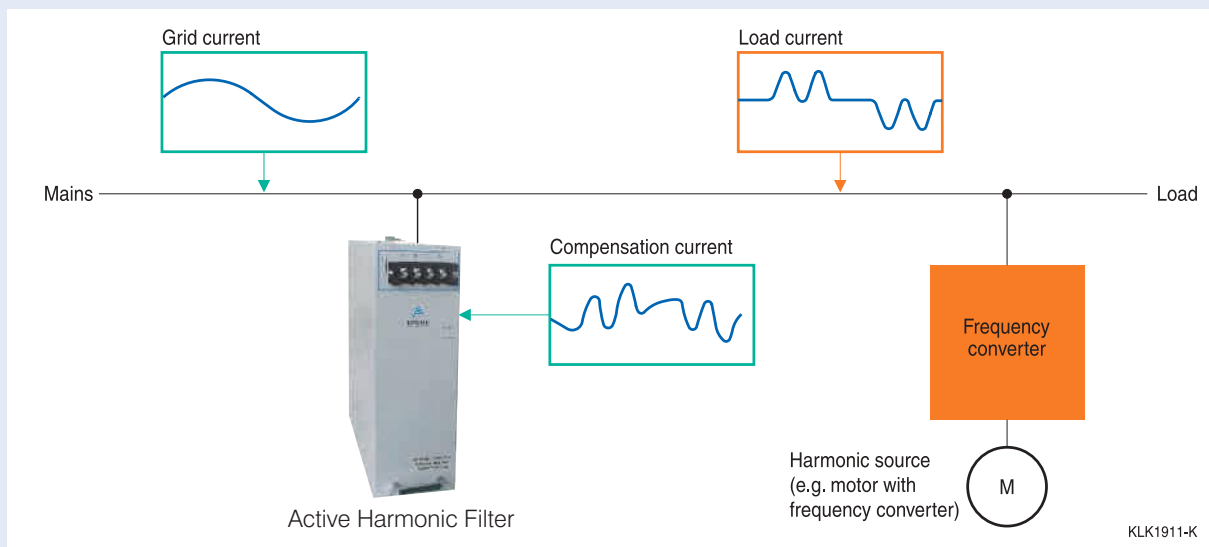

Figure 2: Total harmonic current distortion without active filter

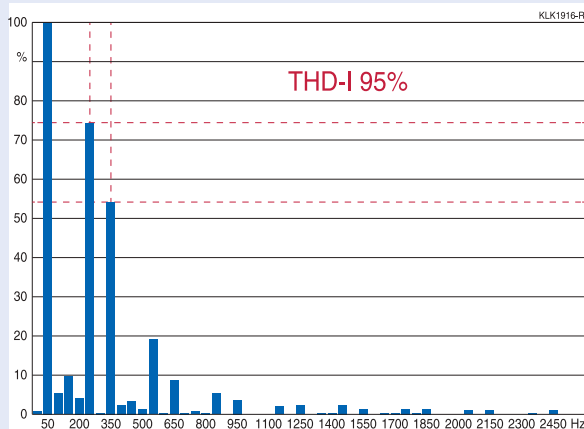
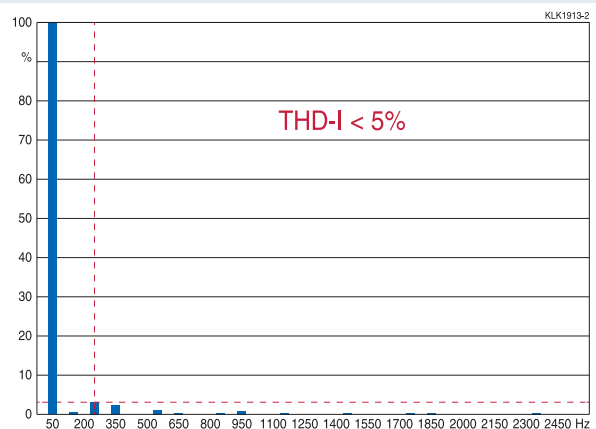

Figure 3: Current harmonics distortion



Active Harmonic Filters and Power Optimizers

PQSine S-Series

Active harmonic filter

With AHF PQSines S-Series
Harmonic disturbances caused by e.g.
active non-linear loads

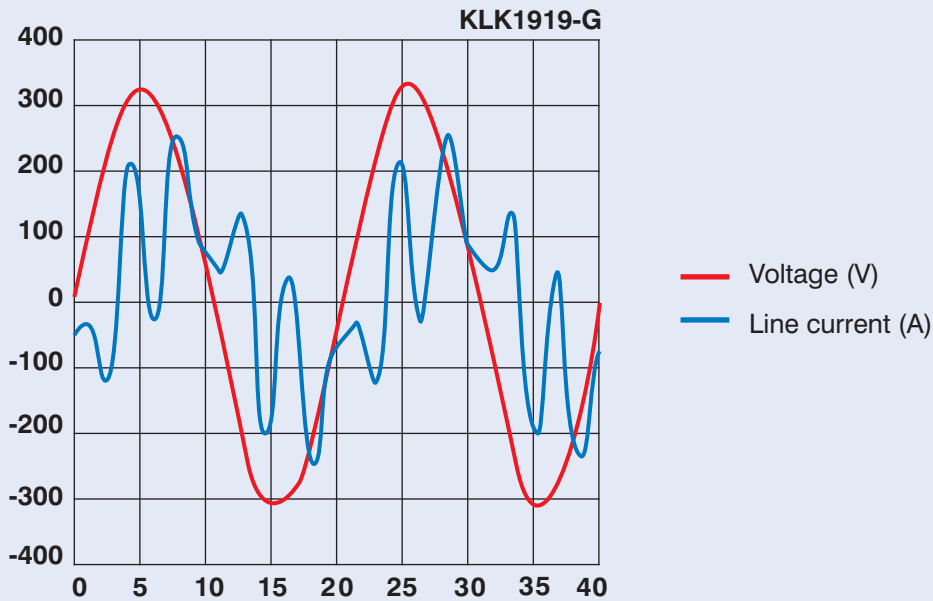

With AHF PQSines S-Series
Reactive power harmonic oscillations are
compensated

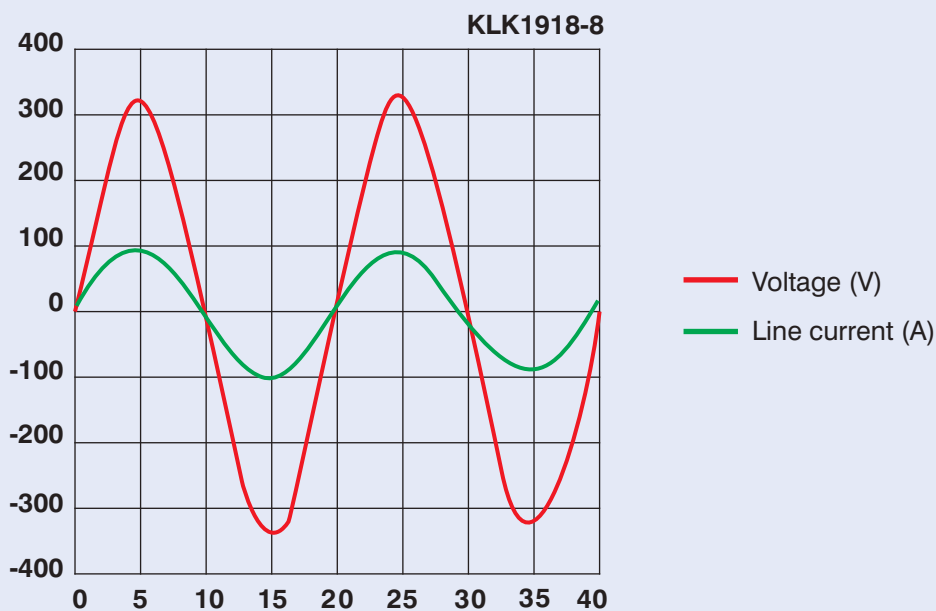

Active Harmonic Filters and Power Optimizers PQSine S-Series

Depending on your needs, TDK offers either complete panels, wall mounted cabinets or modules integrated into full module panels. The State-of-Art modular design of PQSine S-Series offering the advantage that in case of service, the downtime keeps at a minimum.

PQSine S-Series module



PQSine S-Series cabinet



Active Harmonic Filters and Power Optimizers

PQSine S-Series

Advantages of AHF PQSine S-Series three-level NPC topology

The AHF PQSine S-Series range operates on the basis of a three-level Neutral-Point-Clamped (NPC) topology circuit. As can be seen from the diagrams below, the conventional two-level circuit configuration consists of 6 IGBTs (two IGBT power devices in each phase leg and current path). In case of a three-level topology, the circuit configuration consists of 12 IGBTs (four IGBT power devices in each phase leg and current path).

The three-level NPC circuit can produce three voltage levels at the output: the DC bus plus voltage, zero voltage and DC bus negative voltage. The two-level topology can only connect the output to either the plus bus or the negative bus.

It also ensures higher quality and better harmonics of the line-to-line output voltage, thus reducing the output filter requirement and the associated costs.

Two-level topology circuit:

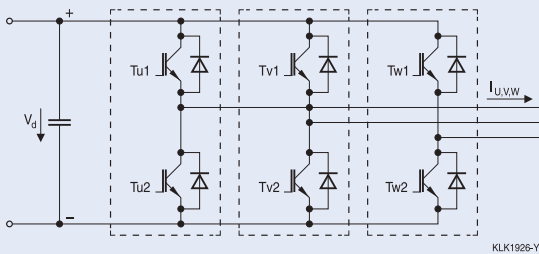

Three-level NPC topology circuit:

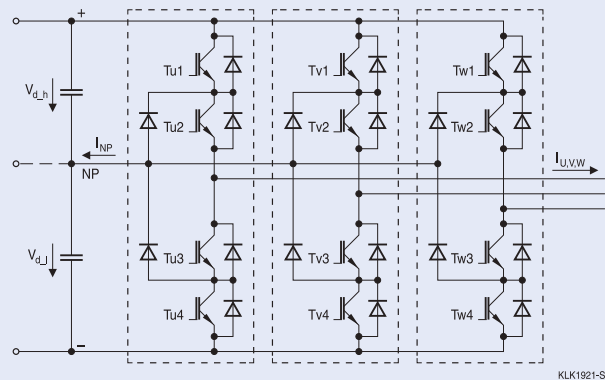

Current and switched output voltage for a two-level topology:

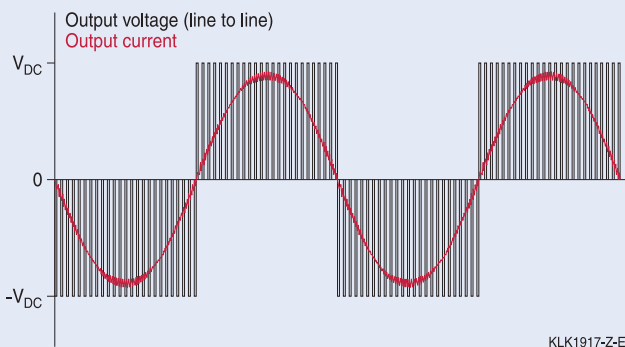

Current and switched output voltage for a three-level NPC topology:

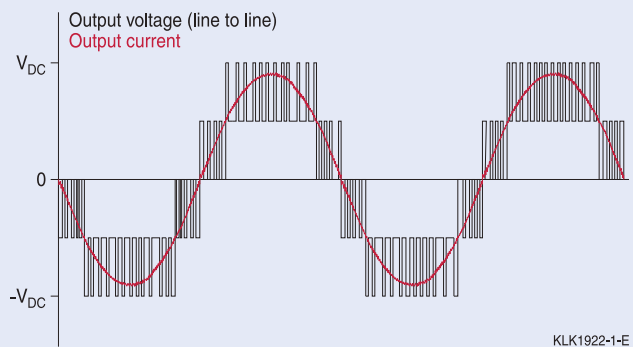

Main advantages of the three-level NPC topology are:

- Lower losses: only half of the voltage has to be switched, thus reducing the switching losses in the transistor. Three-level solutions are characterized by reduced circuit losses and higher efficiency, thus supporting energy-saving concepts.
- Smaller output current ripple: the NPC three-level topology has a lower ripple in the output current and half of the output voltage transient thanks to a higher quality output voltage. This improves performance and reduces the internal filter requirement.

Active Harmonic Filters and Power Optimizers

PQSine S-Series

Technical data and specifications			
Rated voltage	380 V (228 V to 456 V)	480 V (384 V to 552 V)	690 V (480 V to 790 V)
Mains frequency		43...62Hz	
Filter current	25 A, 35 A, 50 A, 60 A, 100 A, 150 A	75 A, 90 A	75 A, 90 A
Neutral filtering capability	3 times the rated filter current(in case of 4 wire device)		
Harmonic current compensation range	2 – 50 harmonic order, or specified harmonics 0-110%		
Rate of harmonic reduction	> 95%		
Target power factor	Adjustable from -1 to 1		
Switching / Control frequency	20 kHz/20 kHz		
Reaction time	< 50 Microseconds		
Overall response time	< 5 ms		
Harmonic compensation	Available		
Reactive power compensation	Available		
Unbalance compensation	Available		
Display	All systems include a 7" TFT color control / display unit (touch screen)		
Communication ports	RS485 and network port (RJ45)		
Communication protocols	Modbus (RTU), TCP/IP(Ethernet)		
Fault alarm	Available, max. 500 alarm records		
Noise level	< 56dB (depending on the model)	< 65dB(depending on the model)	
Protection functions	Over-voltage, under-voltage, short-circuit, in verter bridge inverse, over-compensation		
Operating temperature	-10 to +40 °C without derating		
Relative humidity	5% to 95%, non-condensation		
Cooling	75,151,300,405 L/sec (25-35,50-60,75-100, 150 A)	359 L/sec	
Protection class	IP 20 according to IEC 529		
Panel color	RAL7035 light grey		
Altitude	1500; 1% up 1500 m. Between 1500 m to 4000 m, according to GB/T3859.2, the power decreases by 1% for every additional 100 m		
Qualifications	CE, IEEE 61000	CE, ETL(UL508), IEEE 61000	
Compliance with standards	IEEE 519, ER G5/4		

Active Harmonic Filters and Power Optimizers

PQSine S-Series

400 V PQSine S-Series – 3P4W systems*)							
Type	Rated filter current	System min. /max. voltage		Mounting variant	Approx. weight	Approx. dimensions (WxDxH)	Ordering code
	A	V			kg	mm	
PQSW4025S344	25	228	456	Wall-mounted	18	440x150x470	B44066F4025S344
PQSW4035S344	35	228	456	Wall-mounted	18	440x150x470	B44066F4035S344
PQSW4050S344	50	228	456	Wall-mounted	35	440x190x610	B44066F4050S344
PQSW4060S344	60	228	456	Wall-mounted	35	440x190x610	B44066F4060S344
PQSW4100S344	100	228	456	Wall-mounted	46	440x232x625	B44066F4100S344
PQSW4150S344	150	228	456	Wall-mounted	48	500x270x560	B44066F4150S344
Vertical mounting variant							
PQSF4100S310	100	228	456	Floor-mounted	270	1000x600x2200	B44066F4100S310
PQSF4250S310	150	228	456	Floor-mounted	305	1000x600x2200	B44066F4150S310
PQSF4200S310	200	228	456	Floor-mounted	310	1000x600x2200	B44066F4200S310
PQSF4250S310	250	228	456	Floor-mounted	345	1000x600x2200	B44066F4250S310
PQSF4300S310	300	228	456	Floor-mounted	350	1000x600x2200	B44066F4300S310
Horizontal mounting variant							
PQSF4100S315	100	228	456	Floor-mounted	276	600x1000x2200	B44066F4100S315
PQSF4150S315	150	228	456	Floor-mounted	278	600x1000x2200	B44066F4150S315
PQSF4200S315	200	228	456	Floor-mounted	313	600x1000x2200	B44066F4200S315
PQSF4250S315	250	228	456	Floor-mounted	324	600x1000x2200	B44066F4250S315
PQSF4300S315	300	228	456	Floor-mounted	326	600x1000x2200	B44066F4300S315
PQSF4350S315	350	228	456	Floor-mounted	361	600x1000x2200	B44066F4350S315
PQSF4400S315	400	228	456	Floor-mounted	372	600x1000x2200	B44066F4400S315
PQSF4450S315	450	228	456	Floor-mounted	374	600x1000x2200	B44066F4450S315
PQSF4500S315	500	228	456	Floor-mounted	392	600x1000x2200	B44066F4500S315
PQSF4550S315	550	228	456	Floor-mounted	420	600x1000x2200	B44066F4550S315
PQSF4600S315	600	228	456	Floor-mounted	422	600x1000x2200	B44066F4600S315

*) All systems include a 7" TFT color control / display unit (touch screen). External current transformers are not included.

Active Harmonic Filters and Power Optimizers

PQSine S-Series

400 V PQSine S-Series - 3P3W systems							
Type	Rated filter current	System min. /max. voltage		Mounting variant	Approx. weight	Approx. dimensions (WxDxH)	Ordering code
	A	V			kg	mm	
PQSW3025S344	25	228	456	Wall-mounted	18	440x150x470	B44066F3025S344
PQSW3035S344	35	228	456	Wall-mounted	18	440x150x470	B44066F3035S344
PQSW3050S344	50	228	456	Wall-mounted	35	440x190x610	B44066F3050S344
PQSW3060S344	60	228	456	Wall-mounted	35	440x190x610	B44066F3060S344
PQSW3100S344	100	228	456	Wall-mounted	46	440x232x625	B44066F3100S344
PQSW3150S344	150	228	456	Wall-mounted	48	500x270x560	B44066F3150S344
Vertical mounting variant							
PQSF3100S310	100	228	456	Floor-mounted	270	1000x600x2200	B44066F3100S310
PQSF3150S310	150	228	456	Floor-mounted	305	1000x600x2200	B44066F3150S310
PQSF3200S310	200	228	456	Floor-mounted	310	1000x600x2200	B44066F3200S310
PQSF3250S310	250	228	456	Floor-mounted	345	1000x600x2200	B44066F3250S310
PQSF3300S310	300	228	456	Floor-mounted	350	1000x600x2200	B44066F3300S310
Horizontal mounting variant							
PQSF3100S315	100	228	456	Floor-mounted	276	600x1000x2200	B44066F3100S315
PQSF3150S315	150	228	456	Floor-mounted	278	600x1000x2200	B44066F3250S315
PQSF3200S315	200	228	456	Floor-mounted	313	600x1000x2200	B44066F3200S315
PQSF3250S315	250	228	456	Floor-mounted	324	600x1000x2200	B44066F3250S315
PQSF3300S315	300	228	456	Floor-mounted	326	600x1000x2200	B44066F3300S315
PQSF3350S315	350	228	456	Floor-mounted	361	600x1000x2200	B44066F3350S315
PQSF3400S315		228	456	Floor-mounted	372	600x1000x2200	B44066F3400S315
PQSF3450S315	450	228	456	Floor-mounted	374	600x1000x2200	B44066F3450S315
PQSF3500S315	500	228	456	Floor-mounted	392	600x1000x2200	B44066F3500S315
PQSF3550S315	550	228	456	Floor-mounted	420	600x1000x2200	B44066F3550S315
PQSF3600S315	600	228	456	Floor-mounted	422	600x1000x2200	B44066F3600S315
*) All systems include a 7" TFT color control / display unit (touch screen). External current transformers are not included.							
690 V PQSine S-Series - 3P3W systems*)							
Type	Rated filter current	System min. /max. voltage		Connection variant	Approx. weight	Approx. dimensions (WxDxH)	Ordering code
	A	V			kg	mm	
PQSF3150S615	150	480	790	Floor-mounted	325	600x1000x2200	B44066F3150S615
PQSF3225S615	225	480	790	Floor-mounted	425	600x1000x2200	B44066F3225S615
PQSF3300S615	300	480	790	Floor-mounted	500	600x1000x2200	B44066F3300S615
*) All systems include a 7" TFT color control / display unit (touch screen). External current transformers are not included.							

Active Harmonic Filters and Power Optimizers

PQSine S-Series

400 V PQSine S-Series – modules							
Type	Rated filter current	System min. /max. voltage		Connection variant	Approx. weight	Approx. dimensions (WxDxH)	Ordering code
	A	V			kg	mm	
Vertical mounting variant							
PQSM4025S303	25	228	456	3P4W	18	190x440x470	B44066F4025S303
PQSM4035S303	35	228	456	3P4W	18	190x440x470	B44066F4035S303
PQSM4050S303	50	228	456	3P4W	35	190x440x590	B44066F4050S303
PQSM4060S303	60	228	456	3P4W	35	190x440x590	B44066F4060S303
PQSM4100S303	100	228	456	3P3W	46	230x440x600	B44066F4100S303
PQSM4150S303	150	228	456	3P3W	48	270x500x510	B44066F4150S303
Horizontal mounting variant							
PQSM4025S300	25	228	456	3P4W	18	440x470x150	B44066F4025S300
PQSM4035S300	35	228	456	3P4W	18	440x470x150	B44066F4035S300
PQSM4050S300	50	228	456	3P3W	35	440x590x190	B44066F4050S300
PQSM4060S300	60	228	456	3P3W	35	440x590x190	B44066F4060S300
PQSM4100S300	100	228	456	3P4W	46	440x600x230	B44066F4100S300
PQSM4150S300	150	228	456	3P4W	48	500x510x270	B44066F4150S300
Vertical mounting variant							
PQSM3025S303	25	228	456	3P3W	18	190x440x470	B44066F3025S303
PQSM3035S303	35	228	456	3P3W	18	190x440x470	B44066F3035S303
PQSM3050S303	50	228	456	3P3W	35	190x440x590	B44066F3050S303
PQSM3060S303	60	228	456	3P3W	35	190x440x590	B44066F3060S303
PQSM3100S303	100	228	456	3P3W	46	230x440x600	B44066F3100S303
PQSM3150S303	150	228	456	3P3W	48	270x500x510	B44066F3150S303
Horizontal mounting variant							
PQSM3025S300	25	228	456	3P3W	18	440x470x150	B44066F3025S300
PQSM3035S300	35	228	456	3P3W	18	440x470x150	B44066F3035S300
PQSM3050S300	50	228	456	3P3W	35	440x590x190	B44066F3050S300
PQSM3060S300	60	228	456	3P3W	35	440x590x190	B44066F3060S300
PQSM3100S300	100	228	456	3P3W	46	440x600x230	B44066F3100S300
PQSM3150S300	150	228	456	3P3W	48	500x510x270	B44066F3150S300

Active Harmonic Filters and Power Optimizers

PQSine S-Series

480 V PQSine S-Series UL/CSA – modules							
Type	Rated filter current	System min. /max. voltage		Connection variant	Approx. weight	Approx. dimensions (WxDxH)	Ordering code
	A	V			kg	mm	
Horizontal mounting variant							
PQSM4075S408	75	384	552	3P4W	66	544x640x250	B44066F4075S408
PQSM4090S408	90	384	552	3P4W	66	544x640x250	B44066F4090S408
PQSM3075S408	75	348	552	3P3W	66	544x640x250	B44066F3075S408
PQSM3090S408	90	348	552	3P3W	66	544x640x250	B44066F3090S408
600 V PQSine S-Series UL/CSA – modules							
Type	Rated filter current	System min. /max. voltage		Connection variant	Approx. weight	Approx. dimensions (WxDxH)	Ordering code
	A	V			kg	mm	
Horizontal mounting variant							
PQSM4075S608	75	420	690	3P4W	66	544x640x250	B44066F4075S608
PQSM4090S608	90	420	690	3P4W	66	544x640x250	B44066F4090S608
PQSM3075S608	75	420	690	3P3W	66	544x640x250	B44066F3075S608
PQSM3090S608	90	420	690	3P3W	66	544x640x250	B44066F3090S608
690 V PQSine S-Series UL/CSA – modules							
Type	Rated filter current	System min. /max. voltage		Connection variant	Approx. weight	Approx. dimensions (WxDxH)	Ordering code
	A	V			kg	mm	
Horizontal mounting variant							
PQSM4075S608	75	420	690	3P4W	66	544x640x250	B44066F4075S708
PQSM4090S608	90	420	690	3P4W	66	544x640x250	B44066F4090S708
PQSM3075S608	75	420	690	3P3W	66	544x640x250	B44066F3075S708
PQSM3090S608	90	420	690	3P3W	66	544x640x250	B44066F3090S708
Accessories ordering codes							
Product description 7" TFT HMI Color Control/Display unit, touch screen							Ordering code B44066F9999S230

TDK APFC Panels



Modular, partly compartmentalized design with rack modules

TDK offers wide range of low voltage automatic power factor correction systems. The cutting edge comes from combining the superior technical capability, application engineering knowledge and understanding of power system with world class power capacitors and capacitor accessories. Leader in power capacitors and capacitor accessories now offers custom built and standardized low voltage automatic power factor correction panels of various ratings, configurations and features to suit every application requirement.

The superiority of the panels are rooted on the world class power capacitors and capacitor's accessories combined with unmatched technical capability in application engineering, power system analysis and design. TDK offers a wide range of customized solution to meet every need. Wide choice of capacitors (MPP Resinol filled, MPP gas impregnated, APP – Oil impregnated), high quality Detuning / Antiresonance reactors with highest linearity (5.67%, 6%, 7% and 14%) with appropriate switching devices (capacitor duty contactors or thyristor switching modules), State-of-Art controllers (4 steps to 16 steps) with advanced control, monitoring and protection features, data logging and communication facilities including GSM, housed in well-engineered powder coated CRCA enclosure makes EPCOS APFC panels the preferred choice of power factor improvement solution for every need.

Some of the special features of our APFC Panels are:

- Superior technology combined with application know how.
- Compact and thermally validated design.
- Complete system type tested upto assembly level
- Ease of maintenance.
- Sophisticated integrated modules built in.
- Appropriate selection of components and capacitors.
- Modularity.

In order to meet specific customer requirement TDK offers wide selection of APFC configurations with high degree of customization.

- Panel Shell configuration – Standard
Non Compartmentalized,
Modular
Partly compartmentalized,
Fully compartmentalized.
- Painting – Powder Coating or Liquid coating.
- Installation – Indoor or Outdoor.
- Ingress Protection Class – IP2X ... IP5X.

Contactor Switched Panels

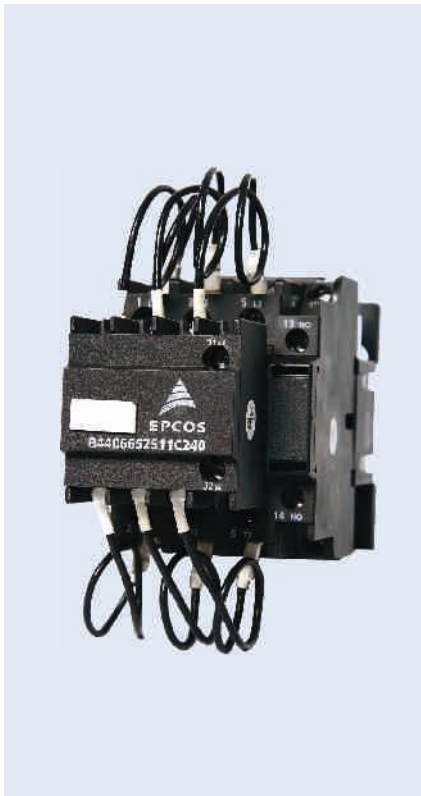

Capacitor duty contactor

TDK contactor switched panels are built with special capacitor switching contactors. Capacitor duty contactors have additional auxiliary contacts with current limiting resistors (also called pre charging resistors) in series with it. The inrush current is limited by these auxiliary contacts coming on first and then the main contacts takes over the steady state current of the capacitors.

Use of capacitor duty contactors enhances the life of capacitors as well as that of the complete system and also limits the system transients thus improving power quality.

For special applications and for system voltages higher than 480V, we offer APFC Panels suitable for operation up to 690V.

Contactor switched APFC panels are more suited for slow varying load or



Standard panel, Switchgear compartment separated from Capacitor + reactor compartment.

intermittent constant loads. These are available with current limiting or detuned harmonic filter reactors. Apart from the controllers these are built with indicating panel meters as well as with step ON-OFF indications. With the given site conditions or load these can be made custom built as well.

The Range of Contactor switched APFC panels

- Voltage – 230V to 1000V.
- KVAR – 7 KVAR to 1500 KVAR.
- Steps – 4 to 16 steps.
- Panel Type – Standard, Semi-compartmentalized and Modular.
- Other type of panels with special feature of GSM, remote control monitoring, special dust protection, chemical industry, humid atmosphere are also available on request.



Modular, partly compartmentalized design with rack modules, contactor switched



Standard or non-compartmentalized design

Thyristor Switched Panels

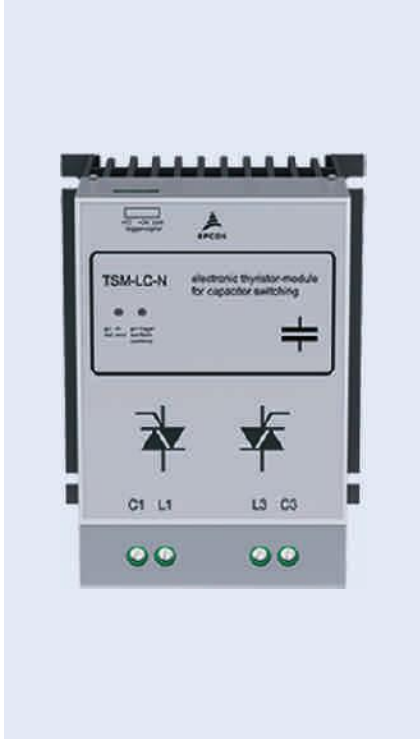

Thyristor switched module

TDK thyristor switched APFC panels are built with world class thyristor switching modules (TSM). These modules are very effective in eliminating the inrush current of capacitors. They are controlled switching devices which can be made to switch on when the voltage across the thyristor is zero, thereby eliminating the inrush current. Additionally, thyristor switching is used when the load variation is rapid as in the case of cranes, lifts, spot welding, plastic extrusion etc. These static switches have a very high speed and thus are ideal for compensating dynamic loads. Since there are no moving parts, the switching life is very high compared to contactors. TDK offers high performance thyristor switching modules for system voltages from 380V to 690V. These modules are natural cooled and are highly reliable and are very compact. The power electronic devices used have a rated PIV of 2200V, one of the highest in its class, thus enhancing the reliability of



Modular, partly compartmentalized design with thyristor switched, front open view

the module. TSM is used with accessories such as 1% (di/dt limiting reactor) and EW22 (quick discharge resistor) to enhance the performance of the system.

Thyristor switched APFC panels are more suited for compensation of fast varying loads such as elevators, cranes, welding, rolling mill loads. These are available with current limiting or detuned harmonic filter reactors. The self diagnostic and natural cooled feature of TSM based panels makes it unique and suitable with very arduous conditions of the loads .

The range of thyristor switched APFC panels

- Voltage – 230V to 1000V.
- Phase – 1Ph or 3 Ph.
- KVAR – 7 KVAR to 1500 KVAR.
- Steps – 4 to 16 steps.

Panel Type – Standard, Semi-compartmentalized and Modular.

Other type of panels with special feature of GSM, remote control monitoring, special dust protection, chemical industry, humid atmosphere or individual phase corrections are also available on request.

Distinguishing Aspects of TDK APFC Panels

- Three Level Testing
 - Component level testing.
 - Sub-assembly level testing.
 - Complete Panel testing.
- Routine and Type tested Capacitor Units.
- Routine and Type tested Damping, and Detuning reactors.
- Routine and Type tested Capacitor Switching Contactors.
- Routine and Type tested Thyristor switching modules.
- Routine and Type tested Advanced APFC Controllers.
- Routine and Type tested Capacitor Rack Modules.
- Individual feeder sub-assembly in the form of Capacitor Rack modules is built with the appropriate choice of protection of properly sized and chosen high speed fuses / MCCB for protection of Thyristor Switched Module based on their characteristics of the Semiconductor Device.
- The Rack module is Type tested and Design Registered with Registration No.235974 dated 05/04/2011 and 235250 dated 15/03/2011.
- The Capacitor Rack Module is fitted with roller wheels which facilitates easy assembly and disassembly in the event of a need for Service.
- One could maintain minimal stock of the Standard Rack Module to ensure that there is no loss of PF improvement in the event of Service need for any particular feeder.
- Panels are well validated for an effective thermal design w.r.t. appropriate placement of heat generating components and to facilitate air flow in a manner in which heat evacuation is effective.
- Routine testing as per latest Indian standard 16636 : 2017.
- The complete APFC panel is also Type tested for some special tests beyond the stated requirements of IS 8623 and IEC 61921.
- Unique, unparalleled in-house test facility for full power testing of APFC Panel to a Rated Voltage up to and including 690V and Rated power up to and including 500 KVAR.
- Facility to inject harmonics, used for validating the performance of critical components viz., capacitors and reactors to almost site-like conditions.
- Facility to do thermal mapping, used for validating first designs over and above the theoretical validation.

Thermal Mapping

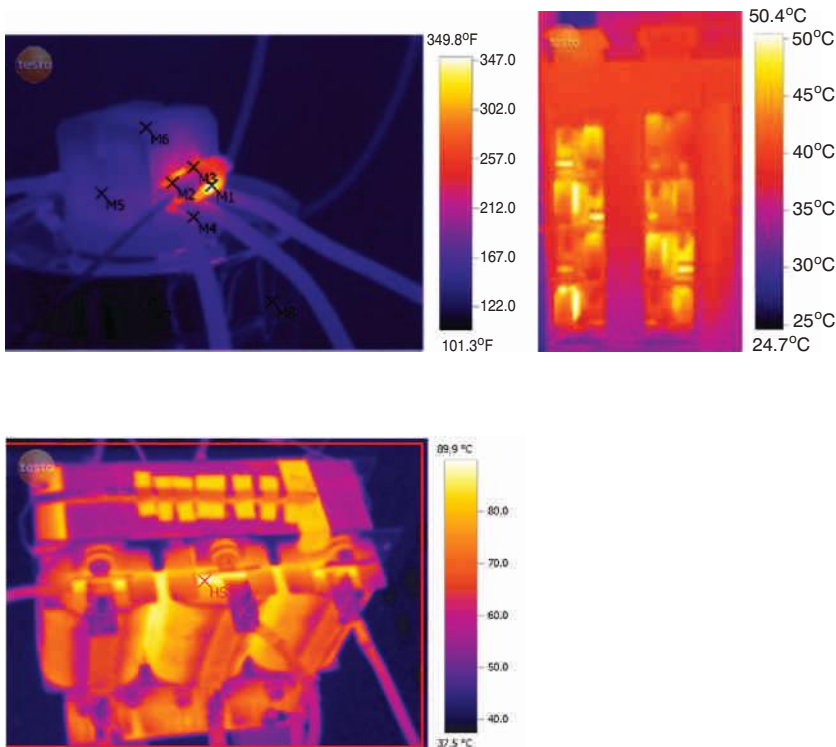

Active Harmonic Generator



List of Testing Facilities:



Unique, unparalleled in-house test facility for full power testing of APFC Panel to a Rated Voltage up to and including 690V and Rated power up to and including 500 KVAR



List of standard equipments:

- Autotransformer (0-440V) and 0-800Amps.
- Autotransformer (0-690V) and 0-500Amps.
- Power Analyser (Fluke and Hioki).
- 5 kV High voltage Testing.
- YOKOGAWA Digital Power meter for watt-loss.
- MEGGER Digital Insulation test meter.
- True RMS Clamp Meter.
- 32 Channel Temperature rise sensor and monitor.

- Digital Coating thickness meter.
- Active Harmonic generator and current injection.
- 500 KVAR APFC panel functional test facility.
- TESTO Thermal imaging Camera.
- TESTO Airflow meter.

List of standard routine tests:

- Visual and dimensional checks.
- Verification of BOM.
- Wiring and harnessing check.
- IR test (megger).
- HV test
- Functionality test in auto and manual mode.
- Output KVAR / Capacitance check.
- Verification of functioning of controller, meters and CT's.

First of its kind temperature chamber of 3m x 3m x 7m where APFC panels can be loaded and tested by maintaining required ambient temperature between 45° C to 55° C

Specifications for APFC Panels

Rated voltage	: 380 / 400 / 415 / 440 / 690 / 1000 V*.
Rated frequency	: 50 / 60 Hz.
Rated output	: 8 - 1700 KVAR*
Configuration	: Delta / Star floating / Star grounded.
Number of steps	: 1 – 16.
Step distribution	: Equal / Binary / unequal.
Detuning reactor	: 0.2%, 1%, 5.67%, 6%, 7%, 14%.
Reactor winding	: Copper / Aluminum strip / Aluminum foil.
Switching device	: Thyristor switched modules / Capacitor duty contactor.
Panel type	: Standard / Modular – Partly compartmentalized / Compartmentalized.
Branch protection	: HRC fuse / High speed fuse for Semiconductor device (TSM) protection / SFU / MCCB.
Capacitors	: Resin filled / Gas impregnated / APP – Oil impregnated.
Protections	: OV / UV / SC / EF / OT.
Controller	: i) BR 4000 / BR 6000 series for single CT sensing application (balanced load). ii) BR 5000 / BR 7000 series for three CT sensing application with RS485 communication as a Standard feature (unbalanced load).
Measuring CT	: 1 for BR 4000 and BR 6000 series. : 3 for BR 5000 and BR 7000 series.
Data logging	: Through controller internal memory in BR 5000 series.
Ingress protection	: IP2X ... IP5X.
Power analyzer	: Optional.
Other unique optional features	: i) Facility of Master / Slave. ii) Facility of Fan failure monitoring. iii) Facility to operate the Panel on Utility supply and Generator supply with different 'target PF' settings. iv) Facility to send hourly Data by GSM to a designated Base station. v) Facility to program key data on the PF Controller through GSM. vi) Facility to receive SMS for designated fault situations. vii) Facility of incorporating a Smoke Detector in the Panel and tripping the main Supply in the event of Smoke detection. viii) Facility of operating Panels on either side of a bus-coupler independently or with the bus coupled. ix) APFC Panels for Outdoor application available. x) APFC Panels for highly corrosive environments available. xi) APFC Panels for Outdoor application used for Distribution Transformer compensation in Utilities with many unique features such as 100 days of Data logging, Neutral fault detection and other multiple fault detection and protection.

* Other Ratings available on request.

Type Test Reports as per latest IS 16636

APFC panels

Contactor switched APFC Panel



Thyristor Switched APFC panel



Capacitor Rack Module



Power Factor Controller – EMI and EMC

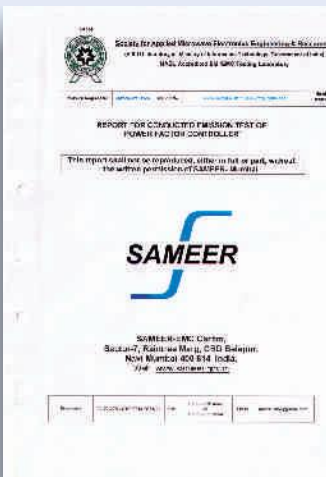

Types of Capacitor Rack Modules

We offer APFC Panels with PFC modules which are ready to assemble in a modular system with various options. These can be quickly

assembled into APFC panels in a very short time thus offering a fast response and shortest delivery time.

Range of capacitor rack modules include:

1. Rating : 5, 10, 12.5, 25, 50 KVAR.
2. Rated voltage : 415 or 440 V.
3. Capacitors : MPP (SH) resin filled or gas impregnated.
4. Switching device : Capacitor duty contactor or thyristor switched module
5. Series reactor : 0.2%, 1%, 5.67%, 7%.

Rack Module with Contactor switching and SFU protection



Rack Module with Contactor switching and MCCB protection



Rack Module with Thyristor switching and high speed fuse protection



Rack Module with Thyristor switching and Isolator+high speed fuse protection



Fundamentals of Power Factor Correction

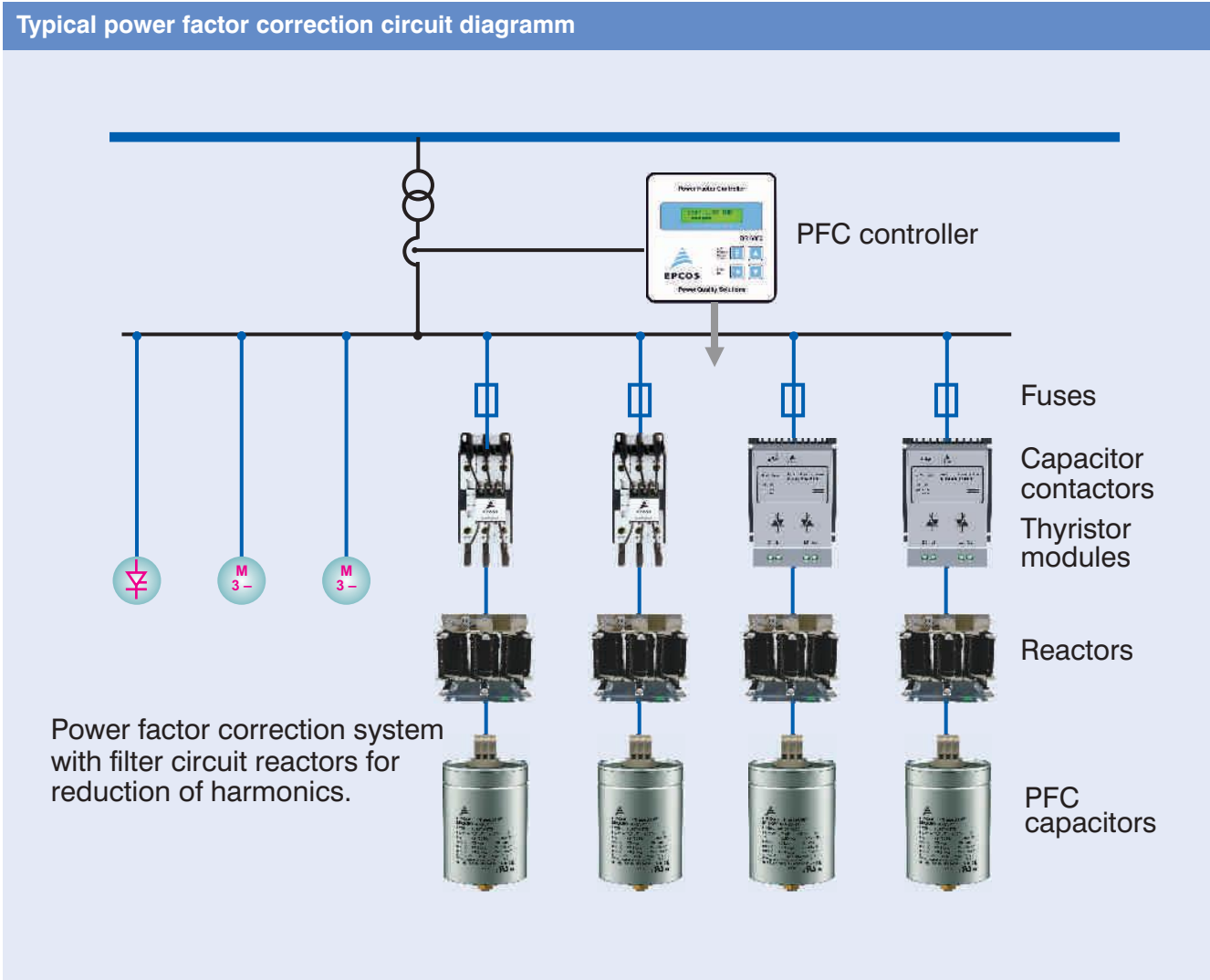

The rational use of electrical energy calls for economical generation, transmission and distribution with little losses. That means restricting all factors in electrical networks that cause losses. One of these factors is lagging reactive power. Loads in industrial and public power grids are primarily of an ohmic-inductive nature. The purpose of systems for power factor correction in networks is to compensate the generated lagging reactive power by leading reactive power at defined nodes. This also serves to avoid impermissibly high voltage drops and additional ohmic losses. The necessary leading power is produced by capacitors parallel to the supply network, as close as possible to the inductive load. Static capacitive compensation devices

reduce the lagging reactive power component transmitted over the network. If grid conditions change, the required leading reactive power can be matched in steps by adding or taking out single power capacitors (automatic PFC) to compensate the lagging reactive power.

Benefits of power factor correction

- Fast return on investment through lower power costs
 - Power factor correction reduces the reactive power in a system.
 - Power consumption and thus power costs drop in proportion.
- Effective use of installation
 - An improved power factor means

that an electrical installation operates more economically (higher effective power for the same apparent power).

- Improved voltage quality
- Reduced voltage drops
- Optimum cable design
 - Cable cross-sections can be reduced with improvement of power factor (less current). In existing installations for instance, extra or higher power can be transmitted.
- Reduced transmission losses
 - The transmission and switching devices carry less current, i.e. only the effective power, meaning that the ohmic losses in the loads are reduced.

Components of Power Factor Correction

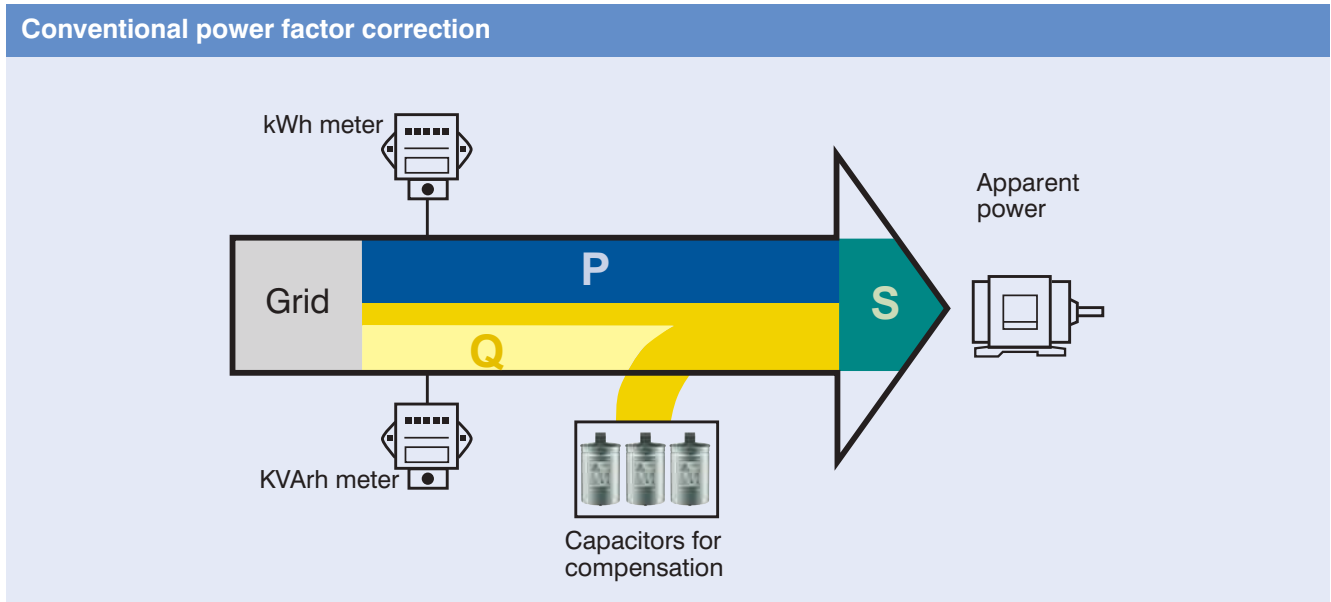

1. Capacitor

Power factor correction (PFC) capacitors produce the necessary leading reactive power to compensate the lagging reactive power. They should be capable of withstanding high inrush currents caused by switching operations ($> 100 \cdot I_R$). If they are connected in parallel, i.e. as banks, the inrush current will increase ($> 150 \cdot I_R$) because the charging current comes from the power line as well as from other capacitors connected in parallel.

- Series PhaseCap and PhaseCap HD dry technology impregnation with an inert gas (nitrogen N_2).
- Series PhaseCap SHD semi-dry biodegradable resin.
- Series PhiCap impregnation with semi-dry biodegradable soft resin.

Design of capacitors

MKK/MKP technology

Metalized plastic compact capacitors with self-healing properties and a polypropylene dielectric. Film metallization with zinc/aluminum alloy results in high performance and a low film thickness allowing significantly more compact dimensions and a lower weight. A heavy edge and special film-cutting technique (optimized combination of wavy and smooth cuts) produces a maximum effective surface for the metal spraying or contacting process

Wavy cut design

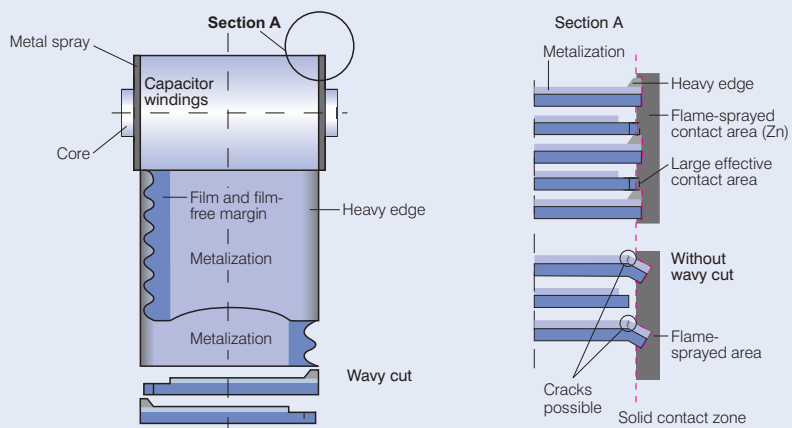

Components of Power Factor Correction

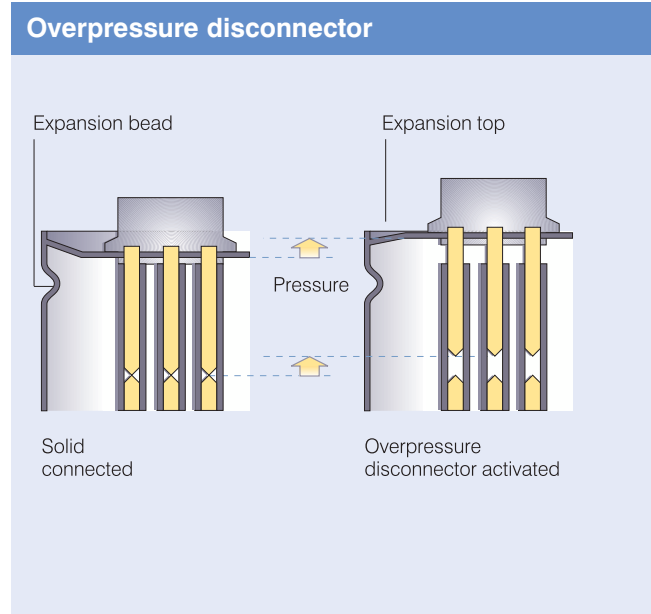
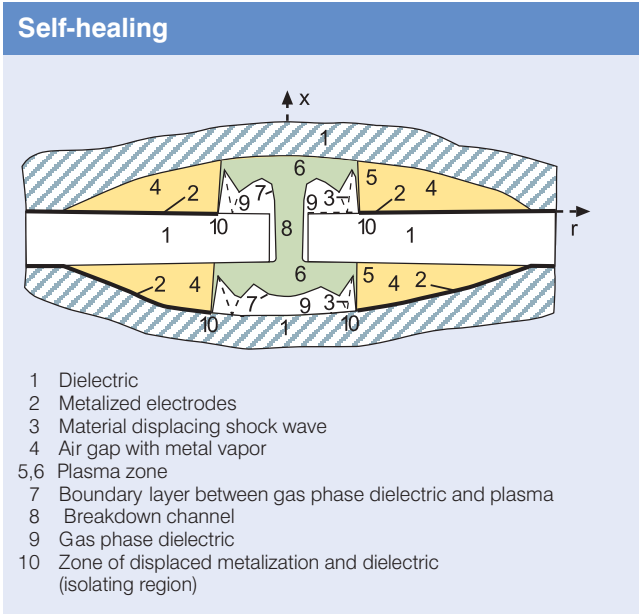

Safety

Self-healing properties

In the event of thermal or electrical overload, an electric breakdown occurs. The dielectric in the breakdown channel is broken down into highly compressed plasma that explodes out of the breakdown channel and pushes the dielectric layers apart. The discharge continues within the spreading plasma via the metal layers so that the metal surrounding the faulty area is completely burnt out. This produces perfect isolation of the faulty area within microseconds. The self-healing process results in negligible capacitance loss – less than 100 pF per event. The capacitor remains fully functional during the entire process.

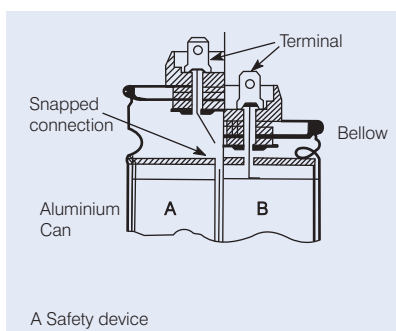
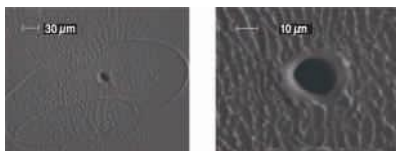

Overpressure disconnector

At the end of the capacitor's service life or when a high pressure forms inside the can, the overpressure disconnector is activated.

The specially designed cover with an expansion bead (or bellow as shown in lower fig.) moves upwards will separate the wires and disconnect the capacitor safely from the line. The disconnector is separated at its break point (small notch) and the flow of current to the capacitor windings is interrupted.

⚠ Caution:

To ensure full functionality of an overpressure disconnector, the following is required:

1. The elastic elements must not be hindered, i.e.
 - connecting lines must be flexible leads (cables),
 - there must be sufficient space (at least 20 mm) for expansion above the connections (specified for the different models),
 - folding beads must not be retained by clamps.
2. The maximum permissible fault current of 10 000 A to the UL 810 standard must not be exceeded.
3. Stress parameters of the capacitor must be within the IEC 60831 specification.

Dry technology/vacuum impregnation

The active winding elements are heated and then dried for a defined period. Impregnation is performed under vacuum. In this way, air and moisture are extracted from the inner capacitor, and oxidation of the electrodes as well as partial discharges are avoided. Afterwards, the capacitor elements are hermetically sealed in cases (e.g. aluminum). This elaborate process ensures excellent capacitance stability and long useful life.

2. Power factor controller

Modern PF controllers are microprocessor based. The microprocessor analyzes the signal from a current transformer and produces switching commands to control the contactors that add or remove capacitor stages. Intelligent control by microprocessor based PF controllers ensures even utilization of capacitor stages, a minimized number of switching operations and an optimized life cycle of the capacitor bank. After the required capacitor output has been determined, the number of steps should be defined. The broad product range of controllers from TDK allows customized solutions: the BR4000 is suited to small PFC systems with 4,6,8 steps.

Components of Power Factor Correction

The BR6000 series is available for conventional, dynamic and mixed compensation with six and twelve steps for medium and large systems respectively.

Rule of thumb: the number of steps depends on the number of loads, i.e. the more small inductive loads, the higher the number of steps should be. The switching time is also of major importance here: the more frequently a capacitor is switched, the more stress is placed on it and its contactors.

3. Multi measuring device

An external meter combining several features in a single device. Combined with the appropriate PF controller, it allows the monitoring, display and storage of various grid parameters. It provides additional protection for the capacitor and the PFC system. As a standalone solution, it acts as a meter, a signal trigger for thyristor modules or as a switch.

4. Switching devices

Two types of switching devices are available from TDK: capacitor contactors and thyristor modules. Before choosing a switching device for a PFC system, the user must consider the number of switching operations.

Capacitor contactor

Contactors are electromechanical switching elements used to switch capacitors or reactors and capacitors in standard or detuned PFC systems. The pre-switching auxiliary contacts of TDK capacitor contactors close before the main contact and avoid peak current values by pre-loading the capacitor. Note: Even when using capacitor contactors, it is important not to exceed the annual switching capability of the particular capacitor series.

Thyristor modules

Fast-changing loads of any kind require technologies that act in real time. In dynamic PFC systems, thyristor modules replace slow-acting electromechanical switches. This not only allows them to react within a few milliseconds, but also increases the life expectancy of all components without any mechanical wear out of the thyristor module.

Note: A dynamic PF controller is required, e.g. of the BR6000-T series.

5. Reactors (compensation and filtering)

Power distribution networks are increasingly subjected to harmonic pollution from modern power electronics devices, known as non-linear loads, e.g. drives, uninterruptible power supplies and electronic ballasts. Harmonics are dangerous for capacitors connected in the PFC circuit, especially if they operate at a resonant frequency. The series connection of a reactor and capacitor to detune the series resonant frequency (the capacitor's resonant frequency) helps to prevent capacitor damage. The most critical frequencies are the 5th and 7th harmonics (250 and 350 Hz at 50 Hz grid frequency). Detuned capacitor banks also help to reduce the harmonic distortion level and clean the network.

⚠ Caution: Appropriate ventilation/air circulation is must, when system is with detuned harmonic filter reactor and capacitor

6. Discharge devices

Discharge resistors

- Discharge resistors are required to discharge capacitors and protect human beings against electric shock hazards as well as to switch capacitors in automatic PFC equipment (opposing phase).
- TDK discharge resistors are designed to discharge capacitors to 50 V or less within 60 seconds.
- Before switching on again, capacitors must be discharged to 10% or less of their nominal voltage.
- Discharge resistors are included in the scope of delivery, pre-mounted for the PhaseCap SHD, PhaseCap HD, PhaseCap EHD and PhiCap series.

⚠ Caution: Discharge and short-circuit the capacitor before handling it!

Discharge reactor

Whenever fast discharge of a capacitor is required, a discharge resistor is not sufficient. Discharge reactors must be used to allow a discharge of within a few seconds. Also, the various steps in a PFC system can then be switched much faster, minimizing losses at the same time.

7. Protection

An HRC fuse or MCCB acts as a safety device for short-circuit protection.

- HRC fuses do not protect a capacitor against overload – they are designed for short-circuit protection only.
- The HRC fuse rating should be 1.6 to 1.8 times the nominal capacitor current.

⚠ Caution: Do not use HRC fuses for switching (risk of arcing!).

Standard Values: Selection Tables for Cables, Cable Cross Sections and Fuses

Selection table			
Power KVA _r	Current A	Cross section mm ²	Fuse rating A
Rated voltage 230 V, 50 Hz			
2.5	6.3	1.5	10
5.0	12.6	4.0	25
7.5	18.8	6.0	35
10.0	25.1	10.0	50
12.5	31.4	16.0	50
15.0	37.7	16.0	63
20.0	50.2	25.0	80
25.0	62.8	35.0	100
30.0	75.8	50.0	125
40.0	100.4	70.0	160
50.0	125.5	95.0	200
75.0	188.3	185.0	315
100.0	251.0	2 x 120.0	400
125.0	-	-	-
150.0	-	-	-
175.0	-	-	-
200.0	-	-	-
Rated voltage 400 V, 50 Hz			
2.5	3.6	1.5	10
5.0	7.2	2.5	16
7.5	10.8	2.5	16
10.0	14.4	4.0	25
12.5	18.0	6.0	35
15.0	28.8	10.0	50
25.0	36.0	16.0	63
30.0	43.2	25.0	80
40.0	57.6	35.0	100
50.0	72.0	50.0	125
75.0	108.3	70.0	160
100.0	144.3	120.0	250
125.0	180.3	185.0	315
150.0	216.5	2 x 95.0	350
175.0	252.6	2 x 95.0	400
200.0	288.0	2 x 120.0	500
Rated voltage 440 V, 50 Hz			
2.5	3.3	1.5	10
5.0	6.6	2.5	16
7.5	10.0	2.5	16
10.0	13.2	4.0	25
12.5	16.8	4.0	25
15.0	19.8	6.0	35
20.0	26.4	10.0	50
25.0	33.0	16.0	63
30.0	39.6	25.0	80
40.0	52.8	35.0	100
50.0	66.0	50.0	125
75.0	99.0	70.0	160
100.0	132.0	95.0	200
125.0	165.0	185.0	315
150.0	198.0	2 x 95.0	350
175.0	231.0	2 x 95.0	400
200.0	264.0	2 x 120.0	500

The above mentioned values are guidelines for operation in normal conditions at ambient temperatures up to 35 °C. Upgrade accordingly if conditions differ, e.g. temperature or harmonics differ. The internal wiring of a capacitor bank is sometimes possible with a smaller cross section. Various parameters such as temperature inside the cabinet, cable quality, maximum cable insulation temperature, single or multi core cable, cable length and laying system have to be considered for a proper selection. The local panelbuilder/installer is responsible for a proper selection of the cable sizes and fuses according to the valid regulations and standards in the specific country where the PFC panels are installed.

Standard Values: Selection Tables for Cables, Cable Cross Sections and Fuses

Selection table			
Power KVA _r	Current A	Cross section mm ²	Fuse rating A
Rated voltage 480 V, 50 Hz			
2.5	3.0	1.5	10
5.0	6.0	2.5	16
7.5	9.0	2.5	16
10.0	12.0	4.0	25
12.5	18.0	6.0	35
15.0	21.0	6.0	35
20.0	24.0	10.0	50
25.0	30.0	10.0	50
30.0	36.0	16.0	63
40.0	48.0	25.0	80
50.0	60.0	35.0	100
75.0	90.0	70.0	160
100.0	120.0	95.0	200
125.0	150.0	120.0	250
150.0	180.0	185.0	315
175.0	210.0	2 x 95.0	350
200.0	240.0	2 x 95.0	400
Rated voltage 525 V, 50 Hz			
2.5	2.7	1.5	10
5.0	5.5	1.5	10
7.5	6.9	2.5	16
10.0	11.0	2.5	16
12.5	13.7	4.0	25
15.0	16.5	4.0	25
20.0	22.0	6.0	35
25.0	27.5	10.0	50
30.0	33.0	16.0	63
40.0	44.0	25.0	80
50.0	55.0	35.0	100
75.0	82.5	70.0	160
100.0	110.0	95.0	200
125.0	137.5	95.0	200
150.0	165.0	185.0	300
175.0	193.0	2 x 95.0	350
200.0	220.0	2 x 95.0	350
Rated voltage 690 V, 50 Hz			
2.5	2.1	1.5	10
5.0	4.2	1.5	10
7.5	6.3	1.5	10
10.0	8.4	2.5	16
12.5	10.5	2.5	16
15.0	12.6	4.0	25
20.0	16.7	4.0	25
25.0	20.9	6.0	35
30.0	25.1	10.0	50
40.0	33.5	16.0	63
50.0	41.8	25.0	80
75.0	62.8	50.0	125
100.0	83.7	70.0	160
125.0	105.0	70.0	160
150.0	126.0	95.0	200
175.0	146.0	120.0	250
200.0	167.0	128.5	315

The above mentioned values are guidelines for operation in normal conditions at ambient temperatures up to 35°C. Upgrade accordingly if conditions differ, e.g. temperature or harmonics differ. The internal wiring of a capacitor bank is sometimes possible with a smaller cross section. Various parameters such as temperature inside the cabinet, cable quality, maximum cable insulation temperature, single or multi core cable, cable length and laying system have to be considered for a proper selection. The local panel builder/installer is responsible for a proper selection of the cable sizes and fuses according to the valid regulations and standards in the specific country where the PFC panels are installed.

Capacitor (KVAR) selection chart

Current (ACTUAL) Tan φ	cos φ	achievable (TARGET) cos φ							Q _c	TARGET Cos φ = 0.96		
		Factor F								Cos φ ≤ 1		
		0.80	0.82	0.85	0.88	0.90	0.92	0.94		0.96	0.98	1.00
3.18	0.30	2.43	2.48	2.56	2.64	2.70	2.75	2.82	2.89	2.98	3.18	
2.96	0.32	2.21	2.26	2.34	2.42	2.48	2.53	2.60	2.67	2.76	2.96	
2.77	0.34	2.02	2.07	2.15	2.23	2.28	2.34	2.41	2.48	2.56	2.77	
2.59	0.36	1.84	1.89	1.97	2.05	2.10	2.17	2.23	2.30	2.39	2.59	
2.43	0.38	1.68	1.73	1.81	1.89	1.95	2.01	2.07	2.14	2.23	2.43	
2.29	0.40	1.54	1.59	1.67	1.75	1.81	1.87	1.93	2.00	2.09	2.29	
2.16	0.42	1.41	1.46	1.54	1.62	1.68	1.73	1.80	1.87	1.96	2.16	
2.04	0.44	1.29	1.34	1.42	1.50	1.56	1.61	1.68	1.75	1.84	2.04	
1.93	0.46	1.18	1.23	1.31	1.39	1.45	1.50	1.57	1.64	1.73	1.93	
1.83	0.48	1.08	1.13	1.21	1.29	1.34	1.40	1.47	1.54	1.62	1.83	
1.73	0.50	0.98	1.03	1.11	1.19	1.25	1.31	1.37	1.45	1.63	1.73	
1.64	0.52	0.89	0.94	1.02	1.10	1.16	1.22	1.28	1.35	1.44	1.64	
1.56	0.54	0.81	0.86	0.94	1.02	1.07	1.13	1.20	1.27	1.36	1.56	
1.48	0.56	0.73	0.78	0.86	0.94	1.00	1.05	1.12	1.19	1.28	1.48	
1.40	0.58	0.65	0.70	0.78	0.86	0.92	0.98	1.04	1.11	1.20	1.40	
1.33	0.60	0.58	0.63	0.71	0.79	0.85	0.91	0.97	1.04	1.13	1.33	
1.30	0.61	0.55	0.60	0.68	0.76	0.81	0.87	0.94	1.01	1.10	1.30	
1.27	0.62	0.52	0.57	0.65	0.73	0.78	0.84	0.91	0.99	1.06	1.27	
1.23	0.63	0.48	0.53	0.61	0.69	0.75	0.81	0.87	0.94	1.03	1.23	
1.20	0.64	0.45	0.50	0.58	0.66	0.72	0.77	0.84	0.91	1.00	1.20	
1.17	0.65	0.42	0.47	0.55	0.63	0.68	0.74	0.81	0.88	0.97	1.17	
1.14	0.66	0.39	0.44	0.52	0.60	0.65	0.71	0.78	0.85	0.94	1.14	
1.11	0.67	0.36	0.41	0.49	0.57	0.63	0.68	0.75	0.82	0.90	1.11	
1.08	0.68	0.33	0.38	0.46	0.54	0.59	0.65	0.72	0.79	0.88	1.08	
1.05	0.69	0.30	0.35	0.43	0.51	0.56	0.62	0.69	0.76	0.85	1.05	
1.02	0.70	0.27	0.32	0.40	0.48	0.54	0.59	0.66	0.73	0.82	1.02	
0.99	0.71	0.24	0.29	0.37	0.45	0.51	0.57	0.63	0.70	0.79	0.99	
0.96	0.72	0.21	0.26	0.34	0.42	0.48	0.54	0.60	0.67	0.76	0.96	
0.94	0.73	0.19	0.24	0.32	0.40	0.45	0.51	0.58	0.65	0.73	0.94	
0.91	0.74	0.16	0.21	0.29	0.37	0.42	0.48	0.55	0.62	0.71	0.91	
0.88	0.75	0.13	0.18	0.26	0.34	0.40	0.46	0.52	0.59	0.68	0.88	
0.86	0.76	0.11	0.16	0.24	0.32	0.37	0.43	0.50	0.57	0.65	0.86	
0.83	0.77	0.08	0.13	0.21	0.29	0.34	0.40	0.47	0.54	0.63	0.83	
0.80	0.78	0.05	0.10	0.18	0.26	0.32	0.38	0.44	0.51	0.60	0.80	
0.78	0.79	0.03	0.08	0.16	0.24	0.29	0.35	0.42	0.49	0.57	0.78	
0.75	0.80		0.05	0.13	0.21	0.27	0.32	0.39	0.46	0.55	0.75	
0.72	0.81			0.10	0.18	0.24	0.30	0.36	0.43	0.52	0.72	
0.70	0.82			0.08	0.16	0.21	0.27	0.34	0.41	0.49	0.70	
0.67	0.83			0.05	0.13	0.19	0.25	0.31	0.38	0.47	0.67	
0.65	0.84			0.03	0.11	0.16	0.22	0.29	0.36	0.44	0.65	
0.62	0.85				0.08	0.14	0.19	0.26	0.33	0.42	0.62	
0.59	0.86				0.05	0.11	0.17	0.23	0.30	0.39	0.59	
0.57	0.87					0.08	0.14	0.21	0.28	0.36	0.57	
0.54	0.88					0.06	0.11	0.18	0.25	0.34	0.54	
0.51	0.89					0.03	0.09	0.15	0.22	0.31	0.51	
0.48	0.90						0.06	0.12	0.19	0.26	0.48	
0.46	0.91						0.03	0.10	0.17	0.25	0.46	
0.43	0.92							0.07	0.14	0.22	0.43	
0.40	0.93							0.04	0.11	0.19	0.40	
0.36	0.94								0.07	0.16	0.36	
00..33	95									0.13	0.33	

$Q_c = PA \times (\tan \phi_1 - \tan \phi_2)$

$Q_c \text{ (KVAR)} = PA \times F = \text{active power (kW)} \times \text{factor "F"}$

$PA = S \times \cos \phi = \text{apparent power} \times \cos \phi$

$\tan \phi_1 + \phi_2$ according to $\cos \phi$ values ref. Table

Example:

ACTUAL motor power

Actual $\cos \phi$

TARGET $\cos \phi$

Factor F from table

P = 100 kW

0.61

0.96

1.01

Capacitor reactive power Q_c

$Q_c = 100 \times 1.01 = 101.0 \text{ KVAR}$

Individual PFC for Motors

Approximate values (specified by the German Electricity Association VDEW) for fixed PFC of motors

Motor nominal rating	Capacitor power rating (1500 r.p.m.*) KVAr	Capacitor power rating (1000 r.p.m.*) KVAr	Capacitor power rating (750 r.p.m.*) KVAr
1 ... 1.9	0.5	0.5	0.6
2 ... 2.9	1.1	1	1.2
3 ... 3.9	1.5	1.6	1.7
4 ... 4.9	2	2.1	2.3
5 ... 5.9	2.5	2.6	2.9
6 ... 7.9	3	3.2	3.5
8 ... 10.9	4	4.2	4.6
11 ... 13.9	5	5.3	5.8
14 ... 17.9	6	6.3	6.9
18 ... 21.9	7.5	8.0	8.6
22 ... 29.9	10	10.5	11.5
30 ... 39.9	approx. 40% of the motor power		
40 and above	approx. 35% of the motor power		

*r.p.m.: revolutions per minute

The capacitor output should be approx. 90% of the apparent power of the motor when idle.

This means a power factor of 0.9 at full load and 0.95...0.98 during idling. Important: The capacitor output must not be rated too high for individual compensated machines where the capacitor is directly connected with the motor clamp.

This especially applies when the machine has a big oscillating weight and still continues to rotate after switching off. The capacitor placed in parallel may act as generator for the motor which will cause serious overvoltages.

The consequence could be heavy damage to the capacitor as well as to the motor.

Individual PFC for Transformers

Standard values for transformers power factor correction		
Rated apparent power of transformer KVAr	Rated capacitor power for oil immersed transformer KVAr	Rated capacitor power for cast resin transformer KVAr
10	1.0	1.5
20	2.0	1.7
50	4.0	2.0
75	5.0	2.5
100	5.0	2.5
160	7.0	4.0
200	7.5	5.0
250	8.0	7.5
315	10.0	8.0
400	12.5	8.5
500	15.0	10.0
630	17.5	12.5
800	20.0	15.0
1000	25.0	16.7
1250	30.0	20.0
1600	35.0	22.0
2000	40.0	25.0
2500	50.0	35.0
3150	60.0	50.0

For an exact calculation of the right capacitor value, following formula can be used:

$$Q_c = I_0\% \cdot \frac{AN}{100}$$

Q_c = needed capacitor (KVAr)

$I_0\%$ = magnetising current of the transformer

AN = apparent rated power of the transformer in KVA

There are regional differences in the guidelines of power suppliers concerning the admissible size of capacitors directly connected with a transformer. Therefore a consultation with the respective power supplier is recommended

before installation of a compensation bank. Modern transformers have laminations which only need low capacity to reverse the magnetism. In case the capacitor output is too high, stress increase may occur during idling.

Detuned PFC in General

When installing capacitors for PFC purpose, the problem of dealing with harmonics has to be faced. They have to be taken into account when designing the PFC system in order to prevent parallel and /or series resonance conditions that would damage the whole electrical system.

When PFC capacitors are connected, the inductance of the transformer together with the capacitors forms a resonant circuit that could be excited by a harmonic current generated by the load. This resonant circuit has a resonance frequency, and if a harmonic current of this frequency (or close to it) exists, it will lead the circuit into a resonance condition where high current will flow through the branches (L: the transformer, and C: the capacitor bank), overloading them and raising the voltage across them and across the whole electrical system that is connected in parallel.

PFC detuned filtering is a technique to correct the power factor avoiding the risk of resonance condition performed by shifting the resonance frequency to lower values where no harmonic currents are present.

This is achieved by modifying the basic LC circuit formed by the transformer and the capacitor bank, introducing a filter reactor in series with the capacitors, making this way a more complex resonant circuit but with the desired feature of having a resonance frequency below the first existing harmonic. This way it's not possible to have a real resonance condition.

Besides this main objective, the reactor connected in series with capacitors form a series resonant circuit with a certain tuning frequency at which the branch will offer a low impedance path. Filtering of harmonic currents and "cleaning" of the grid will be achieved.

Components for PFC detuned filters must be carefully selected according to the desired PFC purpose, to the harmonics present in the system, to some features of the system like short circuit power and impedances, to the desired filtering effect and to the characteristics of the resonant circuit configured.

For example, the voltage across the capacitors will be higher than the nominal grid voltage when they have a reactor connected in series.

The reactors must be selected in line with the inductance value to obtain the desired tuning frequency and current capability high enough for the harmonic current absorption that can be expected. The tuning frequency is usually indirectly referred to as the detuning factor p and expressed as percentage.

$$p = 100 \cdot \frac{X_L}{X_C} = \left(\frac{f}{f_{RES}} \right)^2 \cdot 100$$

f : fundamental frequency
 f_{RES} : tuning frequency

PFC detuned filtering is an engineering speciality that takes experienced know-how to implement it in a satisfying and safe way.

The design instructions for detuned PFC systems on page 87 to 90 have to be followed to ensure an optimum performance of the PFC system.

Note: The recommendations given in the selection tables are meant as a support tool. TDK does not take over any responsibility for the design, as apart from the theoretical conditions the prevailing circumstances in the application have to be taken into account.

Detuned PFC: Important Facts and Instructions

Important design instructions to be followed for detuned PFC Systems

- 1 Determine the necessary effective power (KVA_r) of the capacitor bank in order to obtain the desired PF.
- 2 Design the capacitor stages in such a way that the sensibility of the bank is around 15–20% of the total available power. It's not useful to have a more sensitive bank that reacts with a 5 or 10% of the total power because this would lead to a high amount of switching operations, wasting the equipment unnecessarily when the real objective is to have a high average PF.
- 3 Try to design the bank with standard KVA_r values of effective power steps, preferably multiples of 25 KVA_r.
- 4 Measure the presence of harmonic currents in the main feeder cable of the system without capacitors at all possible load conditions. Determine frequency and maximum amplitude for every harmonic that could exist.

Calculate the Total Harmonic Distortion of Current $THD-I = 100 \cdot \sqrt{[(I_3)^2 + (I_5)^2 + \dots + (I_N)^2]} / I_1$
Calculate every existing value for $THD-I_N = 100 \cdot I_N / I_1$

- 5 Measure the presence of harmonic voltages that might come from outside your system, if possible measure the HV side.
Calculate the Total Harmonic Distortion of Voltage $THD-V = 100 \cdot \sqrt{[(V_3)^2 + (V_5)^2 + \dots + (V_N)^2]} / V_1$
- 6 Are there harmonics such as $THD-I > 10\%$ or $THD-V > 3\%$ (measured without capacitors)?
If YES → use PFC-DF and go to consideration 7.
If NO → use standard PFC and skip considerations 7, 8 and 9.
- 7 Is there 3rd harmonic content, $I_3 > 0.2 \cdot I_5$?
If YES → use PFC-DF with $p = 14\%$ and skip consideration 8.
If NO → use PFC-DF with $p = 7\%$ or 5.67% and go to consideration 8.

- 8 THD-V is:
3–7% → use PFC-DF with $p = 7\%$
>7% → use PFC-DF with $p = 5.67\%$
>10% → ask for special filter design
- 9 Select the proper components using TDK tables for PFC-DF and standard values for effective power, the voltage and frequency of your grid, and the determined detuned factor p .
- 10 Always use genuine TDK application-specific designed components for PFC-DF. Please observe that reactors are specified for their effective power at grid voltage and frequency. This power will be the real effective power of the whole LC set at fundamental frequency. Capacitors for PFC-DF must be selected for a higher rated voltage than the grid's because of the overvoltage caused by the series connection with the reactor. Contactors for capacitors are designed as application-specific to reduce inrush capacitor currents and to handle capacitive loads in a reliable way.

Capacitor Voltage Rating selection guideline for a Detuned Capacitor Bank

General

It is necessary to understand the importance of choosing the right voltage rating while using capacitors in a 'Detuned' system. In commonly accepted technical parlance, we say 'voltage drop across the reactor', however, notice that a capacitor and reactor are electrical components with opposite signs, i.e., $=jX_L$ and $-jX_C$

Hence, when you apply a basic voltage divider formula to these impedances, it's obvious that there exists a steady state voltage 'rise' across the capacitor in the circuit. Now the steady state voltage across the capacitor shall be as follows:

$$V_{cap} = \frac{-jX_C}{-jX_C + jX_L} \times 1pu$$

Where $X_L = p \cdot X_C$

p = Detuning percentage

Example with $p=7\%$ detuning reactor, $X_C=100\Omega$ and $X_L=7\Omega$

$$V_{cap} = \frac{-j100}{-j100 + j7} \times 1pu = 1.075 pu$$

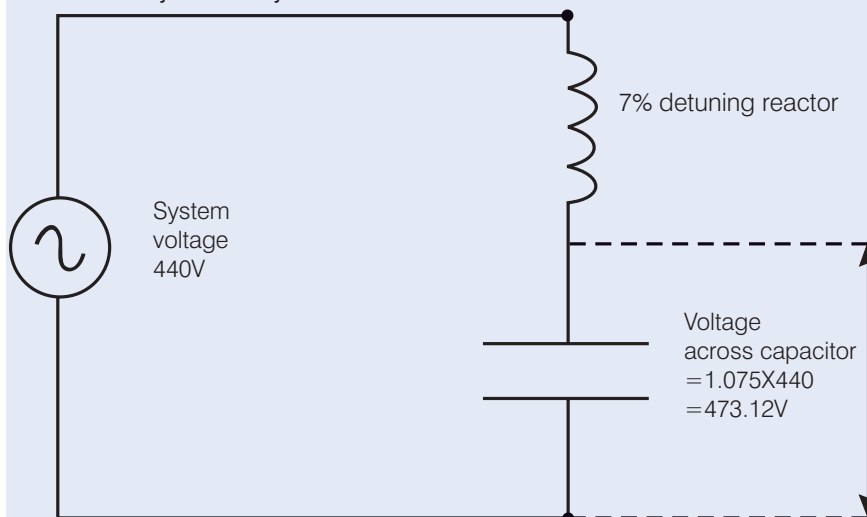

Consider an additional overvoltage factor of 10% towards system voltage variation and harmonic loading. Then the design requirement would be 520.43V. Hence it is recommended that the capacitor voltage rating be chosen at the closest standard voltage rating of 525V.

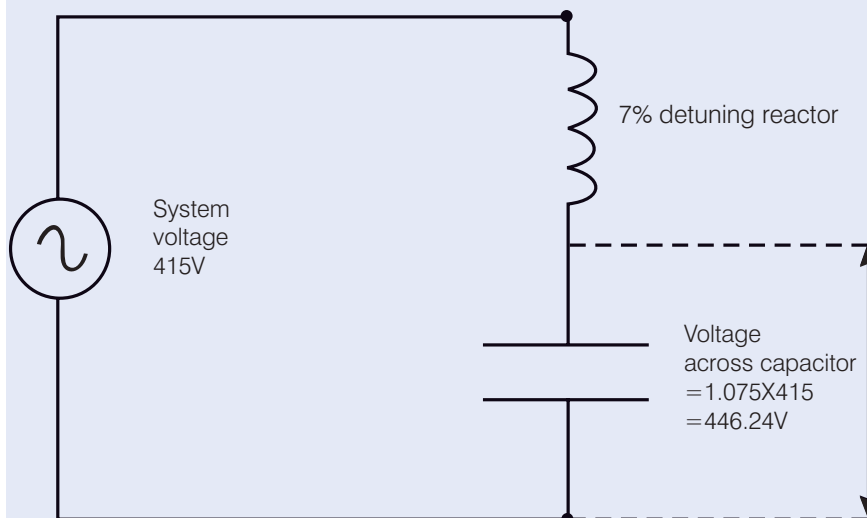

Consider an additional overvoltage factor of 10% towards system voltage variation and harmonic loading. Then the design requirement would be 490.86V. Hence it is recommended that the capacitor voltage rating be chosen at the closest standard voltage rating of 500V, or atleast 480V.

Capacitor Voltage Rating selection guideline for a Detuned Capacitor Bank

Example with $p=14\%$ detuning reactor, $X_c=100\Omega$ and $X_l=14\Omega$

$$V_{\text{cap}} = \frac{-j 100}{-j 100 + j 14} \times 1 \text{ pu} = 1.63 \text{ pu}$$

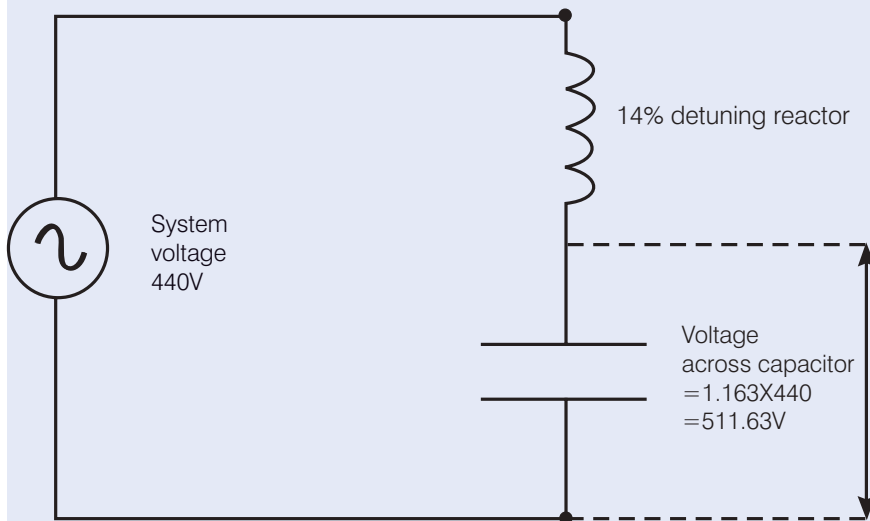

Consider an additional overvoltage factor of 10% towards system voltage variation and harmonic loading. Then the design requirement would be 562.79V. Hence it is recommended that the capacitor voltage rating be chosen at the closest standard voltage rating of 600V.

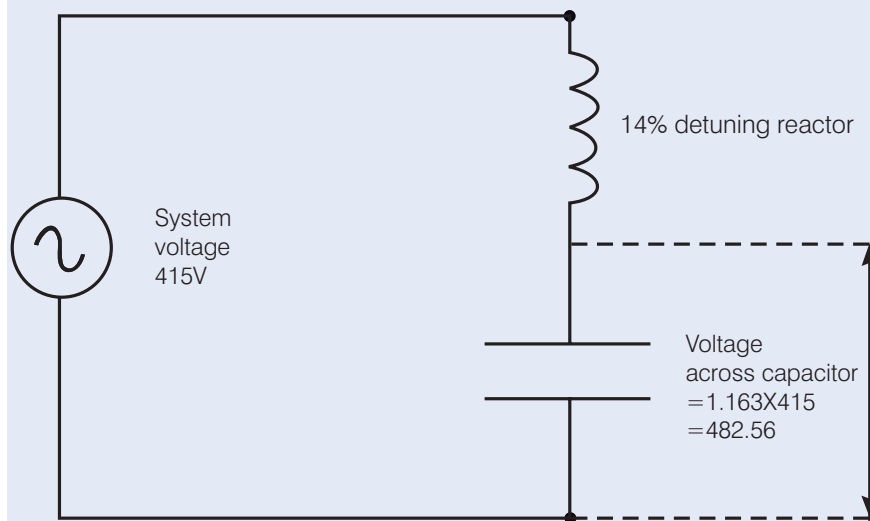

Consider an additional overvoltage factor of 10% towards system voltage variation and harmonic loading. Then the design requirement would be 530.81V. Hence it is recommended that the capacitor voltage rating be chosen at the closest standard voltage rating of 525V.

Capacitor Voltage Rating selection guideline for a Detuned Capacitor Bank

Example with $p = 5.67\%$ detuning reactor, $X_c = 100\Omega$ and $X_L = 5.67\Omega$

$$V_{\text{cap}} = \frac{-j 100}{-j 100 + 5.67} \times 1 \text{ pu} = 1.06 \text{ pu}$$

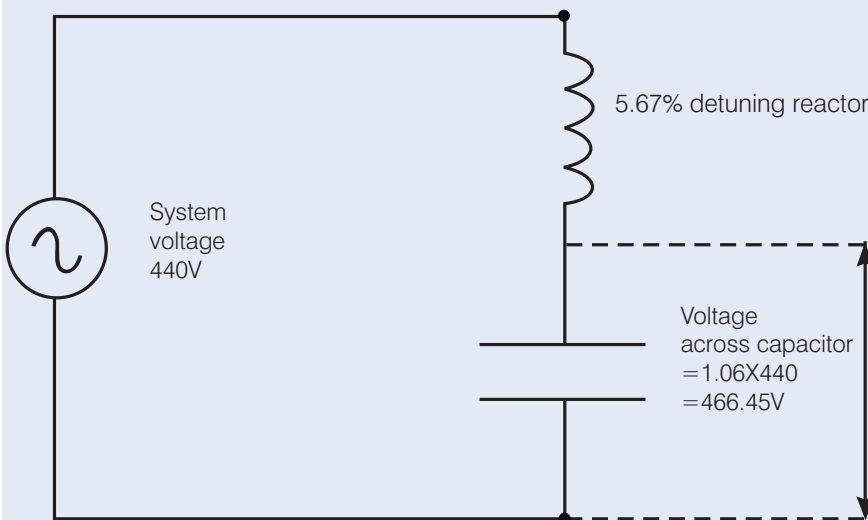

Consider an additional overvoltage factor of 20% towards system voltage variation and harmonic loading. Notice the difference between the previous considerations of detuning. This is due to the fact that the detuning frequency has shifted upwards, more closer towards the 5th Harmonic frequency. This behaves like a partially tuned filter for the 5th Harmonic frequency. Then the design requirement would be 559.74V. Hence it is recommended that the capacitor voltage rating be chosen at the closest standard voltage rating of 600V. It is also preferred that the type of capacitor chosen is one which has a reasonably larger overcurrent capability as well.

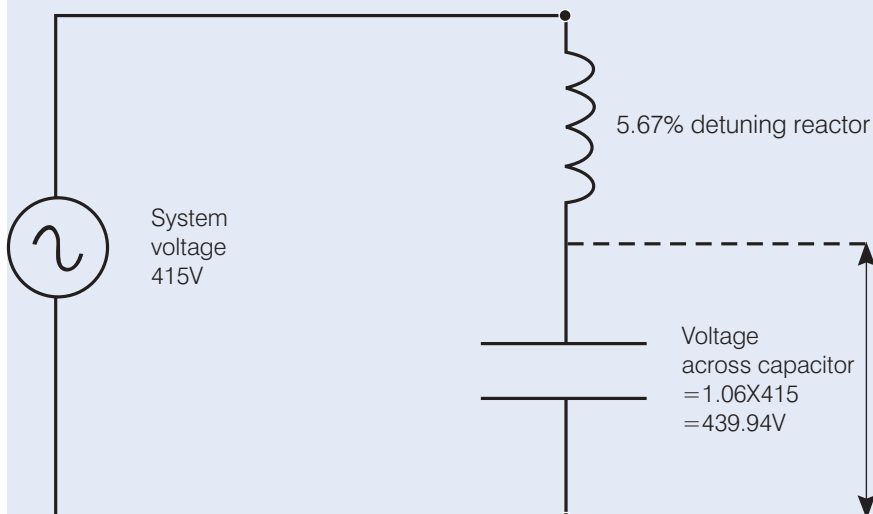

Consider an additional overvoltage factor of 20% towards system voltage variation and harmonic loading. Notice the difference between the previous considerations of detuning. This is due to the fact that the detuning frequency has shifted upwards, more closer towards the 5th Harmonic frequency. This behaves like a partially tuned filter for the 5th Harmonic frequency. Then the design requirement would be 527.93V. Hence it is recommended that the capacitor voltage rating be chosen at the closest standard voltage rating of 525V. It is also preferred that the type of capacitor chosen is one which has a reasonably larger overcurrent capability as well.

Dynamic PFC: Important Facts and Instructions

General

Conventional PFC systems quickly reach their limits when they have to deal with fast changing loads. Applications like rolling mills, steel presses, wind turbines, container cranes and large buildings include a huge amount of electric consumers that require a reactive power adjustment on the mass scale. Production equipment, elevators, chillers, and other electric devices not only require such dynamic reactions of the power factor compensation equipment, they also lead very soon to a total number of switchings that exceeds the specifications of standard electromechanical contactors by far.

In conventional PFC systems, standard capacitor contactors are used to switch capacitor steps on and off. These electromechanical devices offer between 100000 and 200000 switching operations in total during their life time which means that in such an application they reach their life expectancy after 1 to 2 years already. It has to be mentioned that capacitors are much stricter limited with regard to the permitted annual number of switching operations (IEC 60831). This typically results in destruction of their inrush current damping capability and may also damage the contacts in the main power circuit. Burnt main contacts may produce oscillation or "unclean" (re-bouncing) switching operations. This massive overload not only

shortens the life expectancy of the capacitor, but also increases the risk of premature failure and in the worst case represents a potential safety risk.

But furthermore the capacitor itself is specified for a limited number of switching operations per year. The standard IEC 60831 gives an acceptable value of 5000 switching operations per year, a value far below switching numbers up to 100000 that may be required per year in dynamic applications. Such large switching numbers and the respective overvoltages and overcurrents during each switching operation are likely to damage the capacitor and may lead to a very early capacitor failure.

In dynamic PFC systems, the capacitor contactors are replaced by thyristor modules that are suitable for a nearby unlimited number of switching operations as there is no mechanical wear-off. Thyristor modules feature electronic semiconductor switches that are able to react to a changing reactive power demand on the ms scale and that can switch capacitors without additional stress. The Thyristor switches keep the capacitors at the peak value of the grid voltage and connect them only when the grid reaches this peak voltage value. Thus the capacitors are switched current free and inrush currents that can reach values of 200 times the nominal current for conventional contactors are avoided. Additionally capacitor discharge

times up to 50 sec as necessary for conventional PFC is not required here.

In summary dynamic PFC does not only prevent wear-off of the capacitors and the switches and increases thus the lifetime of a PFC system and its safety. It also increases the power quality in the grid essentially as it can almost react in real time to reactive power demands. Fast enough for example, to take care of motor start up effects or spot welding requirements.

TDK offers all necessary key components to set up a dynamic PFC systems as the thyristor modules (TSM, see page 55), the required fast transistor output controllers (BR6000-T, page 39), and standard reactor (page 59) and of course capacitor series (starting from page 11).

PFC Basic Formulae

The following electrical formulas may be used to calculate basic PFC values.

Active power

The amount of input power converted to output power is the active power.

$$P = \sqrt{3} \cdot V \cdot I \cdot \cos \varphi \quad (\text{W})$$

Formula 1

Power factor

The power factor of an AC electrical power system is defined as the ratio of the real (active) power to the apparent power.

$$\text{Power factor} = \frac{\text{Active power}}{\text{Apparent power}} = \frac{P}{S}$$

Formula 4

Reactive power

The reactive power is the power consumed in an AC circuit due to the expansion and collapse of magnetic (inductive) and electrostatic (capacitive) fields.

$$Q = \sqrt{3} \cdot V \cdot I \cdot \sin \varphi \quad (\text{VAr})$$

Formula 2

Power Factor Correction

When the AC load is partly capacitive or inductive, the current waveform is out of phase with the voltage. This requires additional AC current to be generated that is not consumed by the load, creating I²R losses in power cables. Capacitors are used to supply reactive energy to inductive loads. Reactive energy must be produced as closely as possible to the loads to prevent unnecessary flow of current in the network. This is known as power factor correction.

$$Q_C = P \cdot (\tan \varphi_1 - \tan \varphi_2) \quad [\text{VAr}]$$

Formula 5

Q_C: reactive power needed

P : total active power

φ₁ : actual angle of cos φ actual

φ₂ : target angle of cos φ actual

Apparent Power

The apparent power is the power delivered to an electric circuit.

$$S = \sqrt{3} \cdot V \cdot I \quad (\text{VA})$$

Formula 3

Connection and rating of capacitors

The reactive power of the capacitor is a function of its rated voltage and current.

$$Q_C = V_C \cdot I_C \quad [\text{VAr}]$$

Formula 6

$$Q_C = \frac{V_C \cdot V_C}{X_C} = \frac{(V_C)^2}{X_C}$$

Formula 7

$$X_C = \frac{1}{\omega \cdot C} = \frac{1}{2\pi \cdot f \cdot C}$$

Formula 8

f: frequency of network

X_C: impedance of capacitor

C: capacitance value

Formula (7) and (8) together

$$Q_C = (V_C)^2 \omega \cdot C = (V_C)^2 2\pi \cdot f \cdot C$$

Formula 9

PFC Basic Formulae

Capacitor in three-phase PFC application

Three-phase PFC applications have two types of capacitor connections: star and delta.

- STAR connection

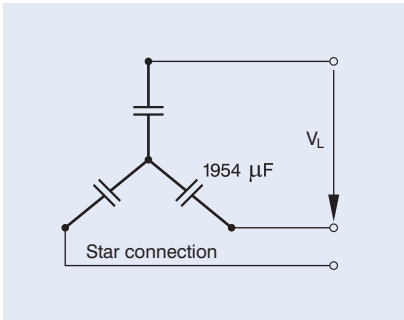

$$Q_{TOT} = 3 \cdot Q_C$$

Formula 10

$$V_C = V_L / \sqrt{3}$$

Formula 11

From formulae (9), (10) and (11)

$$Q_{TOT} = 3 \cdot \frac{(V_L)^2}{(\sqrt{3})^2} \cdot \omega \cdot C_{STAR}$$

$$C_{STAR} = \frac{Q_{TOT}}{(V_L)^2 \cdot \omega} = \frac{Q_{TOT}}{(V_L)^2 \cdot 2\pi \cdot f}$$

Formula 12

- DELTA connection

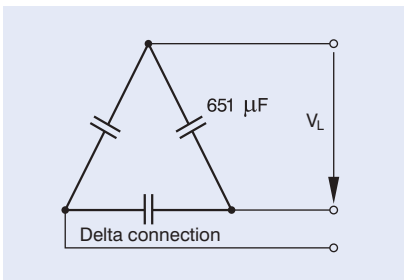

$$V_C = V_L$$

Formula 13

From formulae (9), (10) and (13)

$$Q_{TOT} = 3 \cdot (V_L)^2 \cdot \omega \cdot C_{DELTA}$$

$$C_{DELTA} = \frac{Q_{TOT}}{3 \cdot (V_L)^2 \cdot \omega} = \frac{Q_{TOT}}{3 \cdot (V_L)^2 \cdot 2\pi \cdot f}$$

Formula 14

As a conclusion formula (12) and (14)

$$C_{DELTA} = \frac{C_{STAR}}{3}$$

Formula 15

Capacitor output kvar:

From the formula (9), if we find the Q_{new} with ratio: C will be constant.

$$Q_{New} = \left(\frac{V_{New}}{V_R} \right)^2 \cdot \frac{f_{New}}{f_R} \cdot Q_C$$

Formula 16

These values are operating conditions:

Q_{new} : new reactive power

V_{new} : new voltage

f_{new} : new frequency

These values are the values capacitor is designed:

Q_C : rated capacitor reactive power

V_C : rated capacitor voltage

f_R : rated frequency

Calculation examples

Example 1:

The relationship between active, reactive and real power and $\cos \phi$

In the diagram below, the power triangle shows an initial power factor of 0.70 for a 100 kW (real power) inductive load. The reactive power required by the load is 100 KVAR. By installing a 67-KVAR capacitor, the apparent power is reduced from 142 to 105 KVAR, resulting in a 26% reduction in current. The power factor is improved to 0.95.

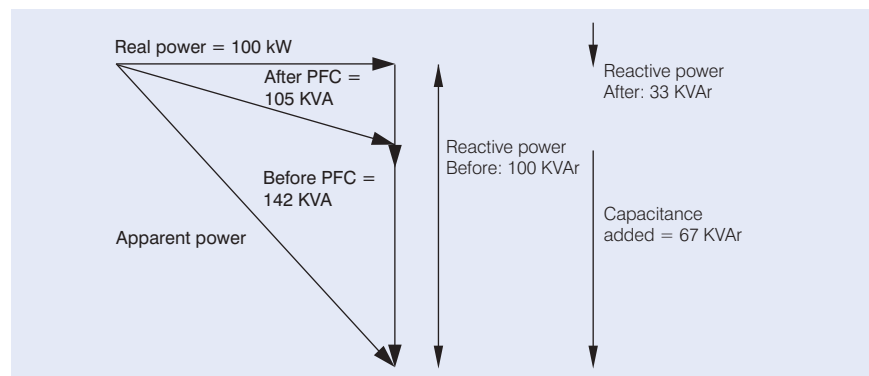

Formulas used (1), (2), (3) and (4).

Power factor calculations:

Before PFC: $100/142 = 0.70$ or 70%

After PFC: $100/105 = 0.95$ or 95%

PFC Basic Formulae

Example 2: Calculation of capacitor rating for industrial installation

- Given parameters:

Induction motor	220 kW
Network (line delta)	440 V AC, 3-phase
Frequency	50 Hz
Power factor	
– Current $\cos \varphi$	0.7
– Target $\cos \varphi$	0.9

Target to correct the power factor to 0.9:

$$\begin{aligned} \cos \varphi_1 &= 0.7 & \tan \varphi_1 &= 1.02 \\ \cos \varphi_2 &= 0.9 & \tan \varphi_2 &= 0.48 \\ Q_C &= P (\tan \varphi_1 - \tan \varphi_2) \\ &= 220 \cdot 1000 (1.02 - 0.48) \\ &= 118.8 \text{ KVAR} \end{aligned}$$

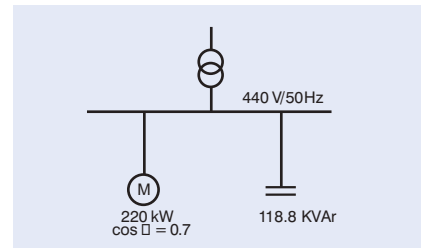

Example 3: Calculating capacitor ratings for DELTA and STAR connections in example 2

STAR connection:

$$V_C = \frac{V_L}{\sqrt{3}} = \frac{440}{\sqrt{3}} = 254 \text{ V}$$

$$C_{STAR} = \frac{Q_{TOT}}{(V_L)^2 \cdot \omega} = \frac{Q_{TOT}}{(V_L)^2 \cdot 2\pi \cdot f}$$

$$\begin{aligned} C_{STAR} &= \frac{118.8 \cdot 1000}{(440)^2 \cdot 2\pi \cdot 50} \\ &= 1954 \text{ } \mu\text{F} / \text{Line (phase)} \end{aligned}$$

$$C_{TOT} = 5862 \text{ } \mu\text{F}$$

DELTA connection:

$$V_C = V_L = 440 \text{ V}$$

$$C_{DELTA} = \frac{Q_{TOT}}{3 \cdot (V_L)^2 \cdot \omega} = \frac{Q_{TOT}}{3 \cdot (V_L)^2 \cdot 2\pi \cdot f}$$

$$\begin{aligned} C_{DELTA} &= \frac{118.8 \cdot 1000}{3 \cdot (440)^2 \cdot 2\pi \cdot 50} \\ &= 651 \text{ } \mu\text{F} / \text{Line (phase)} \end{aligned}$$

$$C_{TOT} = 1954 \text{ } \mu\text{F}$$

Example 4: Calculating apparent power reduction (S1–S2) in example 2

$$\begin{aligned} S_1 &= P / \cos \varphi_1 = 220 / 0.7 \\ &= 314 \text{ kVA} \end{aligned}$$

$$\begin{aligned} S_2 &= P / \cos \varphi_2 = 220 / 0.9 \\ &= 244 \text{ kVA} \end{aligned}$$

$$S_1 - S_2 = 70 \text{ kVA}$$

Thus, additional power of $70 \cdot (0.9) = 63 \text{ kW}$ can be supplied and transferred via the existing network.

Cable cross section calculation

Line current drawn by the motor:

I_1 uncompensated load (0.7):

$$I_1 = \frac{220 \cdot 1000}{\sqrt{3} \cdot 440 \cdot (0.7)} = 412 \text{ A}$$

I_2 compensated load (0.9):

$$I_2 = \frac{220 \cdot 1000}{\sqrt{3} \cdot 440 \cdot (0.9)} = 320 \text{ A}$$

Thus, the cable can carry an additional load of 92 A, or the designer can reduce the cable cross section.

Cautions

Temperature class of capacitors (according IEC 60831-1)			
Temperature class	Temperature of capacitor surrounding air		
	Maximum	Maximum mean for 24 h	Maximum mean for 1 year
B	45 °C	35 °C	25 °C
C	50 °C	40 °C	30 °C
D	55 °C	45 °C	35 °C

Enclosure of capacitors (IPxx)		
Enclosure	First digit	Second digit
Ip00	No protection against finger touch and ingress of solid foreign bodies	No protection against ingress of water
Ip20	protection against finger touch and solid foreign bodies ≥ 12.5 mm diameter	No protection against ingress of water
Ip41	protection against tool touch and solid foreign bodies ≥ 1 mm diameter	Deep-water protection
Ip54	protection against tool touch and solid foreign bodies ≥ 1 mm diameter, protection against dust deposit	Splash-water protection

Maximum admissible overvoltage			
Frequency (50 /60 Hz)	Ma x. voltage (V_{rms})	Max. duration	Remarks
Line frequency	$1.00 \cdot V_R$	Continuous duty	Highest mean during entire operating time of capacitor; exceptions (see below) are admissible for times of < 24 h
Line frequency	$1.10 \cdot V_R$	8 h daily	Line voltage fluctuations
Line frequency	$1.15 \cdot V_R$	30 min daily	Line voltage fluctuations
Line frequency	$1.20 \cdot V_R$	5 min daily	Line voltage fluctuations
Line frequency	$1.30 \cdot V_R$	1 min daily	Line voltage fluctuations
Line frequency with harmonics	Such that current does not exceed maximum admissible figure ($I_{max.} = 1.3 \cdot I_R$)		

Temperature class of capacitors to standard IEC 60831-1

Capacitors are divided into temperature classes. Each class is represented by a number followed by a letter, e.g. –40/D. The number is the lowest ambient temperature at which a capacitor may operate. The upper limit temperature is indicated by the letter (see table above).

The useful life of a capacitor depends very much on temperature. Proper cooling of a capacitor must ensure that the maximum temperature is not exceeded, otherwise useful life is degraded. When configuring a circuit, one should make sure that capacitors are not subjected to heat from

adjacent components (reactors, bus bars, etc). Forced cooling is preferable for compact designs. And it is highly inadvisable to arrange capacitors directly above reactors. Exceeding specified temperature limits may set in worst case the safety device out of operation.

Cautions

Enclosure of capacitors (IPxx)

For different models there are different types of enclosure. The type of enclosure is indicated by a designation consisting of the two letters IP followed by two digits.

Current rating /maximum admissible overcurrent

The rated current (I_R) is the current resulting for rated voltage (V_R) and frequency (in Hz), excluding transients. Maximum permitted rms current for each particular capacitor is specified in the data sheet. Continuously exceeding of the nominal current will lead to increased self-heating of the capacitor and reduce life time. The maximum admissible overcurrent (I_{max}) of $1.3 \cdot I_R$ to IEC 60831 standard is maintained or overachieved by all capacitors in this catalog. The figures for overcurrent allow for the combined effects of harmonics, over voltage and capacitance tolerance.

Maximum admissible overvoltage

Capacitors from TDK are suitable for operation on overvoltages quoted by IEC 60831 (see table). Overvoltages higher than $1.15 \cdot V_R$ reduce life time of the capacitor and must not occur more than 200 times during life time of capacitor. Overvoltages above $1.3 \cdot V_R$ must not occur at all, appropriate overvoltage protection (e.g. against lightning strikes) must be ensured.

Mean life expectancy

The mean life expectancy of power capacitors is mainly governed by the following factors:

- duration of overload,
- ambient temperature and the resulting case temperature,
- maximum rms current and the resulting case temperature,
- voltage height and duration.

The calculated life expectancy of the various series is stated for nominal operating conditions. If components are stressed less than the IEC 60831 factors, longer useful life can be expected, and a correspondingly shorter one or increased failure rate if nominal parameters are exceeded.

Fuse protection

Power capacitors have to be protected against short circuits by fuses or thermal magnetic overcurrent relays. Slow-blow, low-voltage high-breaking-capacity fuses (HRC) are preferable. The fuse rating should be 1.6 to 1.8 times the rated current of the capacitor. Magnetic short circuit relays should be set to between 9 and 12 times rated current to prevent them responding to high inrush currents. Maximum allowed fault current of 10 000 A in accordance with UL 810 standard must be ensured by the application design.

⚠ HRC fuses must not be used for switching. Resulting electric arcing can cause death! It may also cause capacitor failures, and result, worst case, in capacitor bursting and fire.

Cautions

Switching of capacitors

When a capacitor is switched to an AC system, the result is a resonant circuit damped to a greater or lesser degree. In addition to the rated current, the capacitor accepts a transient current that is a multiple of (up to 200 times) its rated current. Fast switching, low-bounce contactors should be used, and have the switching capacity for capacitive currents stated by the producer. Special capacitor contactors with leading contacts that feature precharging resistors to damp inrush currents are recommended. As per IEC 60831 standard, a maximum of 5 000 switching operations per year is acceptable. Before considering a higher number of switching operations, please contact TDK sales office.

Discharging

Capacitors must be discharged to a maximum of 10% of rated voltage before they are switched in again. This prevents an electric impulse discharge in the application, influences the capacitor's useful life in PFC systems, and protects against electric shock. The capacitor must be discharged to 50 V or less within 1 min. There must not be any switch, fuse or any other disconnecting device in the circuit between the power capacitor and the discharging device. TDK supplies capacitor discharge resistors to all series, alternatively discharge reactors are available.

⚠ Caution: Discharge and short circuit capacitor before handling!

Capacitors in networks with harmonics

Harmonics are produced in the operation of electric loads with a nonlinear voltage/current characteristic (e.g. rectifiers and inverters for drives, welding apparatus and uninterruptible power supplies). Harmonics are sinusoidal voltages and currents with higher frequencies of a multiple of the 50 or 60 Hz line frequency. In low-voltage three-phase systems the 5th and 7th harmonics are especially troublesome. Detuned PFC should be used in systems subject to harmonics. This represents a series resonant circuit of power capacitor and reactor. The circuit is tuned so that the series resonant frequency is below the lowest harmonics

appearing in the system. This produces an inductive response to all frequencies above the series resonant frequency, avoiding resonances with system inductances. Depending on the selected series resonant frequency part of the harmonic current is taken up by the detuned PFC system. The remainder of the harmonic current flows into the superordinate system. The use of detuned PFC thus contributes to reducing voltage distortion through harmonics and lessens the disturbing effect on proper operation of other electric loads.

Most international standards limit THD-V on LV side to 5%. However it has to be noted that in many grids these levels are exceeded and even lower distortion, e.g. 3–4% THD-V can generate extreme overcurrents in case of resonance condition.

Maximum overcurrents as specified under technical data of each series must not be exceeded.

Resonance must be avoided by appropriate panel design. Resonance may cause very high overcurrents which can lead to capacitor failures, and worst case, to explosion and fire.

Cautions

Mechanical damage

In case of dents or any other mechanical damage, capacitors must not be used at all.

Vibration resistance

The resistance to vibration of capacitors corresponds to IEC 68, part 2–6.

Max. test conditions:

Test duration	2 h	
Frequency range	10 ... 55 Hz	corresponding to max. 0.7 g
Displacement amplitude	0.75 mm	

Because the fixing and the terminals may influence the vibration properties, it is necessary to check stability when a capacitor is built in and exposed to vibration.

Irrespective of this, you are advised not to locate capacitors where vibration amplitude reaches the maximum in strongly vibrating equipment.

Connection

Make sure connection cables are of flexible type or flexible copper bands are used. This is mandatory to allow the overpressure disconnecter work and avoid mechanical stress on the terminals and feedthroughs.

The connection cables to the capacitor should be designed for a current of at least 1.5 times the rated current so that no heat is conducted into the capacitor. If reactors are used in an application, the distance between reactor and capacitor must be great enough so that no heat of the reactors, which are operating at a much higher temperature level, is conducted via connection cable to the capacitors.

Avoid bending cable lugs, cables or other mechanical force on the terminals. Otherwise leakages may set the safety device out of operation.

Ensure firm fixing of terminals, fixing torque to be applied as per individual specification.

Maximum specified terminal current (please refer to technical data of specific series) must not be exceeded at any case.

Grounding

The threaded bottom stud of the capacitor has to be used for grounding. In case grounding is done via metal chassis that the capacitor is mounted to, the layer of varnish beneath the washer and nut should be removed.

Storage and operating conditions

Do not use or store capacitors in corrosive atmosphere, especially where chloride gas, sulfide gas, acid, alkali, salt or the like are present. In dusty environments regular maintenance and cleaning especially of the terminals is required to avoid conductive path between phases and/or phases and ground.

Installation

Specifications like IEC 61921, VDE 0100, VDE 0101, VDE 0560 part 4 and 46, EN 60831 and IEC60831 apply to the installation and operation of power capacitors. Capacitors should be sited in cool and well ventilated locations away from other heat-radiating elements. Natural heat dissipation is generally sufficient for cooling purposes if enough air is able to flow to and away from them and the capacitors are spaced at least 20 mm apart. Otherwise, in a less well ventilated environment, forced cooling (fans) will be necessary, scaled so that the maximum admissible ambient temperature is not exceeded.

Keep at least 20 mm space above the capacitor and do not attach any component on the top. This gap will allow a longitudinal extension of can in order to ensure that over-pressure disconnecter can fully extend.

Useful life of capacitors strongly depends on the operating temperature (refer to page 95, temperature classes of capacitors).

Exceeding maximum allowed temperature may set the safety device out of operation.

Please read the Installation and Maintenance Instructions on the internet at www.epcos.com/pfc.

Note

Products shown in this catalog reflect typical specifications. You are kindly requested to approve our product specifications or request our approval for your specification before ordering.

Cautions

Reactors- Antiresonance harmonic filter

During operation, all electrically active parts of this equipment such as windings, electronic components, leads, fuses and terminals carry a dangerous voltage which can lead to burns or electric shock.

Covers which protect these electrically active parts from being touched must not be opened or removed during operation.

Before any assembly or maintenance work is started, all installations and equipment must be disconnected from the power source.

Noncompliance with these instructions may lead to death, serious injury or major damage to equipment.

In order to exclude impermissible temperatures and thus overload of the insulation system, the following directions must additionally be observed:

1. Only those protective devices specified on the type plates, such as fuses and motor protection switches, may be used. It is mandatory to observe the set values specified for the motor protection switches. Any temperature-sensitive protective devices such as temperature switches and temperature sensors must be connected in accordance with the installation instructions.
2. High temperatures are permissible for the surfaces under rated operating conditions, and especially in the event of overload. Depending on the temperature class and type of loading, these may attain values of up to 260°C and may also affect adjacent components which have been packed too densely.

3. The insertion position should be selected so that any cooling ducts present within the winding are arranged vertically and that the current of cooling air is not impeded by adjacent components, connecting leads etc.
4. The maximum voltage of the insulating system specified on the type plate must not be exceeded.

Noncompliance with these instructions may lead to considerable damage to equipment or fire due to impermissibly high temperatures.

Thyristor modules (TSM-series)

- Live parts in the PFC equipment must not be touched!
- Warning signs in the PFC systems are required!
- Wait 10 minutes after the main switch is turned off – until the voltage in the system has dropped to a non critical value.
- In non-detuned systems (400 V grid) capacitors with a higher voltage rating (e.g. 440 V) are needed.
- In detuned systems (400 V grid) capacitors with a voltage of 525V are needed.
- For discharging the capacitors, special high-voltage resistors type EW-22 are required. Standard resistors cannot be used!
- In dynamic PFC systems discharge reactors cannot be used (this would be a short circuit of the highvoltage DC)!
- In PFC systems without filter circuit reactors current limiting reactors are required (e.g. BD-series) for the TSM.
- For short circuit protection, super - fast electronic fuses for protection of the thyristor are required, standard HRC fuses are not suitable. See selection table on pages 81 and 82.
- Failure to follow cautions may result, worst case, in premature failures or physical injury.

Capacitor contactors

In case auxiliary contacts are used for switching of discharge resistors (not in accordance with IEC60831 standard), make sure that the current of the discharge resistors is not higher than the rated current of the auxiliary contacts.

Only flame-resistant and self-extinguishing materials may be used in the proximity of capacitor contactors because abnormal temperatures cannot be ruled out in the area near the resistance spirals.

Capacitor contactors C230/N230 may only be used in PFC systems with reactors.

PF controllers (BR4000, BR5000 BR6000 and BR2100 series)

Controller hunting: When putting the capacitor bank into operation, it is required to avoid needless switching cycles (means permanent switching on and off of steps without significant change of consumer loads). This so called “controller hunting” would increase the number of switching operations of the connected contactors and capacitors, decrease the expected life cycle (wear out) and result, in worst case, in bursting and fire etc. This can be avoided by a proper programming of the PFcontrollers with the actual system parameters (current transformer prim. and sec., first KVAr step, control series, switching time).

The “ZVEI General safety recommendations for power capacitors” must be observed in addition to the safety instructions given in this catalogue and in the particular data-sheets. They are available on the EPCOS website in the various product groups. They may also be called up from the ZVEI website.

Contacts:

Factory:

TDK India Private Limited
Plot No. E22 – 25,25/1 MIDC Area Satpur,
Nashik 422007 / India
Telephone: +91 253 2205100/286
Fax: +91 253 2353761
css.NA@tdk-electronics.tdk.com

Sales Offices:

North:
TDK India Private Limited
2nd Floor, Tower - A,C-28, 29,
Logix Cyber Park Sector - 62,
Noida - 201301, India
T: +91 120 450 5801
F: +91 120 450 5818

East:
TDK India Private Limited
Aspirations Conclave
22A, Nakuleshwar Bhattacharjee Lane,
4th floor,
(Lane beside Banana Leaf Restaurant,
Opposite Lake Market)
Kolkata 700 026
Telephone: +91 33 2419 8815

West:
TDK India Private Limited
908,909, Damji Shamji Business Galleria,
L.B.S. Marg,Kanjur Marg (W),
Mumbai - 400 078 / Maharashtra,INDIA
Telephone: +91 22 2575 0800
Fax: +91 22 2575 0810

South:
TDK India Private Limited
#87, CENTURM, 4th Floor, Infantry Road,
Bengaluru - 560 001
Tel: +91 80 4039 0600
Fax: +91 80 4039 0603

Service Contacts:

North:
TDK India Private Limited
2nd Floor, Tower - A,
C - 28, 29, Logix Cyber Park,
Sector - 62,
Noida - 201301, India
Phone: +91 120 450 5815
Fax: +91 120 450 5818
customercare.ND@tdk-electronics.tdk.com

West:
TDK India Private Limited
908,909, Damji Shamji Business Galleria,
L.B.S. Marg,Kanjur Marg (W),
Mumbai - 400 078 / Maharashtra,INDIA
Telephone: +91 22 2575 0812
Fax: +91 22 2575 0810
customercare.MB@tdk-electronics.tdk.com

South:
TDK India Private Limited
#87, CENTURM, 4th Floor, Infantry Road,
Bengaluru - 560 001
Karnataka
Tel: +91 80 4039 0645
Fax: +91 80 4039 0603
customercare.BG@tdk-electronics.tdk.com

Nashik Factory:
TDK India Private Limited
Plot No. E22 – 25 MIDC Area Satpur,
Nashik 422007 / India
Telephone: +91 253 2205 100/286
Fax: +91 253 2353761
css.NA@tdk-electronics.tdk.com

Note: Any complaint on products and services, please log in to <http://tipl.in.tdk-electronics.tdk.com/services/>

TDK India Pvt. Ltd.

Sales Head Office:
#87, CENTURM, 4th Floor, Infantry Road, Bengaluru - 560 001.
Tel: +91-80-4039 0600. Fax :+91-80-4039 0603.
Email: sales.in@tdk-electronics.tdk.com.

TDK PFC Product Profile R2 2019 ... 012019 ...

"Product development is a continuous process. Consequently the data indicated in this catalogue is subject to change without prior notice. For the latest information, contact your local partners."