

CTX³ RTX³ MPX³

UNCOMPROMISING
PERFORMANCE
FOR MOTOR
PROTECTION
AND CONTROL



THE GLOBAL SPECIALIST
IN ELECTRICAL AND DIGITAL BUILDING INFRASTRUCTURES

 **legrand**[®]



CTX³ RTX³ MPX³ A SENSE OF FAMILY

There are requirements for control and protection of motors in all sectors: heating, ventilation and air conditioning in commercial buildings; pumps, compressors, conveyors and machines in industrial buildings, etc. Legrand's new contactors, thermal relays and motor protection circuit breakers provide a response for all these applications.

Their high performance levels, perfect complementarity, compact size, ease of mounting, wide range of auxiliaries, etc. make them suitable for installation in all distribution boards and control enclosures.



INDEX

2	A COMPLETE RANGE OF DEVICES FOR THE PROTECTION AND CONTROL OF MOTORS
4	CTX ³ : CONTROL OF CIRCUITS
6	CTX ³ MINI: AN ULTRA-COMPACT SOLUTION
8	RTX ³ : THERMAL PROTECTION OF MOTORS
10	ACCESSORIES FOR ALL APPLICATIONS
12	MPX ³ : MAXIMUM EFFICIENCY IN A COMPACT UNIT
14	AUXILIARIES AND ACCESSORIES PROVIDING FLEXIBILITY
16	CATALOGUE PAGES

A COMPLETE RANGE OF DEVICES FOR THE PROTECTION AND CONTROL OF MOTORS



CTX³ CONTACTORS AND RTX³ THERMAL RELAYS UP TO 800 A

- Compact size
- High mechanical and electrical endurance for maximum reliability
- 3-pole and 4-pole contactors
- Screw terminals
- Complete range of auxiliaries and accessories

3-POLE CTX³ CONTACTORS

4-POLE CTX³ CONTACTORS



RTX³ thermal relays





MPX³ MOTOR PROTECTION CIRCUIT BREAKERS UP TO 100 A

- High breaking capacity and type 2 coordination for an optimum service level
- Trip class 10
- Sensitive to phase loss
- Compact size
- Can be fixed on 35 mm DIN rail or using screws
- Easy combination with CTX³ 3-pole contactors
- Complete range of control and signalling auxiliaries and accessories

STANDARD
BREAKING
CAPACITY

HIGH BREAKING CAPACITY

MAGNETIC ONLY



MPX³ 32S
0.16 A - 100 kA
to 32 A - 15 kA



MPX³ 32H
0.16 A - 100 kA
to 32 A - 50 kA



MPX³ 63H
10 A - 100 kA
to 63 A - 50 kA



MPX³ 100H
17 A - 100 kA
to 100 A - 75 kA



MPX³ 32MA
0.16 A - 100 kA
to 32 A - 50 kA

CTX³: CONTROL OF CIRCUITS UP TO 800⁽¹⁾ A

With a comprehensive selection of ratings, control voltages, auxiliaries and accessories, and total complementarity with CTX³ power contactors, RTX³ thermal relays and MPX³ circuit breakers provide an ideal solution for motor switching and controlling circuits for the most demanding applications.

⁽¹⁾ 900 A for 4P contactors

CTX³ 225/400/800: MOUNTING ON PLATE UP TO 800 A

- 1 Connection plates for bars or lugs
- 2 Pre-mounted auxiliary contact blocks (2 per contactor). Additional auxiliary contact blocks can be mounted on the right or left of the contactors.





The 4-pole version of CTX³ contactors is available from 20 to 900 A (AC-1).

CTX³ 22/40/65/100/150: MOUNTING ON DIN RAIL OR ON PLATE UP TO 150 A

- 3 IP 2X terminals: screw terminals up to 40 A, screw or cage terminals from 50 to 100 A
- 4 Integrated auxiliary contacts
- 5 A1 and A2 supply terminal block (top and bottom)



Common time-delay modules and auxiliary contact blocks for all CTX³ up to 150 A.

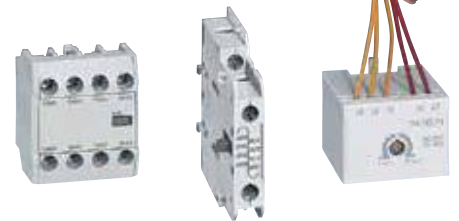

CTX³ contactors can be fitted with a safety cover.

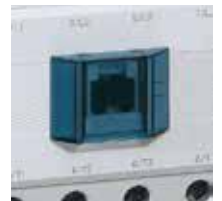

CTX³ MINI: AN ULTRA-COMPACT SOLUTION UP TO 16 A

With their compact size, CTX³ MINI are easy to integrate in control panels or distribution boards for switching motors, lighting and heating circuits up to 16 A.



CTX³ MINI: MOUNTING ON DIN RAIL OR ON PLATE

- ① IP 2X screw terminals
- ② Integrated auxiliary contact (3P only)
- ③ A1 and A2 supply terminal block



The flexible wire kits allow to associate freely two CTX³ mini 3-pole contactors and make very compact assemblies for motor reversing. For motors up to 7.5 kW 415 V.

AUXILIARIES AND ACCESSORIES FOR EVEN MORE APPLICATIONS

CTX³ mini contactors can take front and side-mounting additional auxiliary contact blocks and a mechanical interlock module.

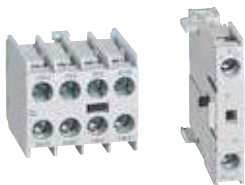

CTX³ control relays take the same auxiliaries as the CTX³ mini.



Plate and connector for joining a CTX³ mini and an MPX³ 32 motor circuit breaker together directly to create a compact motor starter.

RTX³: THERMAL PROTECTION OF MOTORS

RTX³ thermal relays provide protection against overloads, long starting times and prolonged stalling of the motor. They are very easy to install, connecting directly beneath CTX³ contactors.



- ① Trip indicator
- ② Off/test button
- ③ Adjustment of the trip threshold of the thermal protection
- ④ Reset button and mode selector switch: automatic (A)/manual (H)
- ⑤ Sealable protective cover
- ⑥ Integrated auxiliary contacts (1 NO + 1 NC)
- ⑦ IP20 terminals



COMPACT MOTOR STARTERS



Mounting directly beneath contactors or separately (up to 150 A) with the dedicated accessory.

A COMPLETE RANGE



RTX³ thermal relays can be used to create 0.1 A to 800 A motor starters when combined with contactors, from the CTX³ mini to the CTX³ 800.

ACCESSORIES FOR ALL APPLICATIONS

With the wide range of accessories, CTX³ contactors can be used in a wide variety of applications:

- Switching capacitor banks
- Supply inverter
- Reversing contactor
- Time-delay motor starter
- Control unit on machine, etc.



FRONT-MOUNTING BLOCK FOR SWITCHING CAPACITORS

Auxiliary blocks for switching capacitors are installed directly on CTX³ 3-pole, 9 to 100 A contactors. With their discharge resistors, they reduce current peaks during switching of capacitor banks.



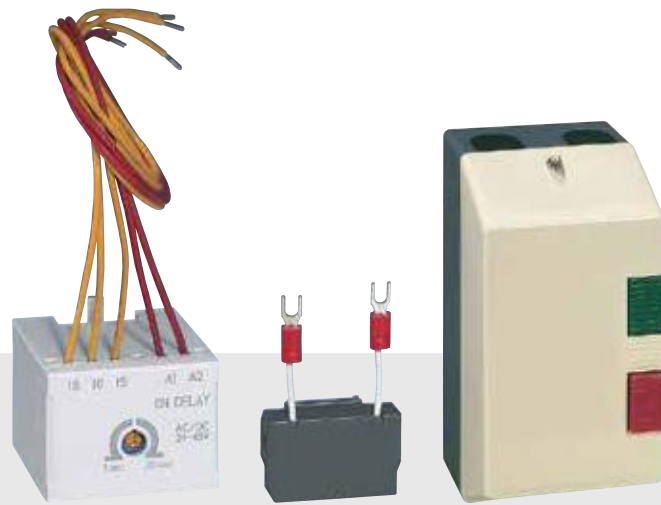

Time-delay modules, transient voltage suppression module, motor starter units, etc., a complete range of accessories for all requirements.

MECHANICAL AND ELECTRICAL INTERLOCKING FOR 3 AND 4-POLE CONTACTORS



The mechanical interlock devices, with or without electrical interlocking, can be used to create 9 to 800 A inverters for 3P contactors, and 20 to 900 A inverters for 4P contactors.

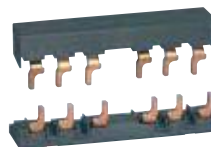

The connection kits make it very easy to create 3P reversing contactors up to 100 A.

MPX³: MAXIMUM EFFICIENCY IN A COMPACT UNIT

With just 4 sizes of unit, the MPX³ range of circuit breakers offers uncompromising performance levels and functions for the protection of motors up to 45 kW.



1 IP 2X terminals



MPX³
32
screw

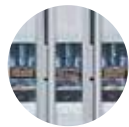

MPX³
63/100
cage

2 Front and side mounting of auxiliary contacts

3 Mount on  rail

4 Wide current adjustment range

5 Settings protected by a sealable transparent cover (optional)



6 Test function

7 Handle can be padlocked in OFF position



8 Label-holder



Certification

- EC declaration of conformity
- UL listed



IEC 60947, UL 508
UL 508 Type E

A COMPLETE RANGE UP TO 100 A IN 4 SIZES



> 45 mm <
MPX³ 32S



> 45 mm <
MPX³ 32H/MA



> 55 mm <
MPX³ 63H



> 70 mm <
MPX³ 100H

BREAKING CAPACITIES ICU AT 415 V_~

MPX³ 32S

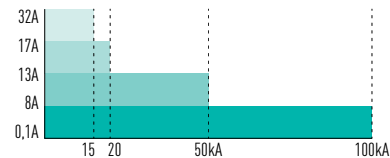

MPX³ 32H/MA

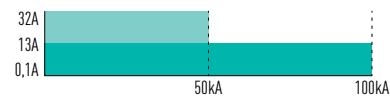

MPX³ 63H

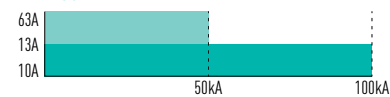

MPX³ 100H



PERFECT COMPLEMENTARITY WITH CTX³ CONTACTORS



Using the dedicated accessories, MPX³ motor circuit breakers and CTX³ contactors can be joined together directly to create compact motor starters.

AUXILIARIES AND ACCESSORIES PROVIDING FLEXIBILITY

Whatever the specifications of your installation, you will always find a solution from the wide range of dedicated auxiliaries and accessories for MPX³ circuit breakers.



ELECTRICAL AUXILIARIES COMMON TO ALL SIZES OF MPX³

- ① Front-mounting auxiliary contacts



- ② Side-mounting auxiliary contacts and fault signal contacts

- ③ Side-mounting shunt trips and undervoltage releases



Possible combinations of auxiliaries

AUXILIARIES			MPX ³ 32S		MPX ³ 32H/MA		MPX ³ 63H		MPX ³ 100H		
AUXILIARY CONTACTS	FRONT-MOUNTING	MAX. NO.	0	1 or	0	1 or	0	1 or	1	0	1 or
	SIDE-MOUNTING	MAX. NO.	2	1	2	1	2	1	0	2	1
FAULT SIGNAL CONTACT		MAX. NO.	0	1	0	1	0	1 ⁽¹⁾	1 ⁽²⁾	0	1 ⁽²⁾
SHUNT TRIP OR UNDERVOLTAGE RELEASE		MAX. NO.	1	1	1	1	1	1	1	1	1

⁽¹⁾: Cat.No 4174 07 - ⁽²⁾: Cat.No 4174 08

A COMPLETE RANGE OF DEDICATED ACCESSORIES FOR EASIER INSTALLATION

Supply busbars and terminals for connecting the circuit breakers in parallel.



Remote rotary control for mounting on door and IP65 unit with black or red rotary handle.



Plates and connectors for creating motor starters.

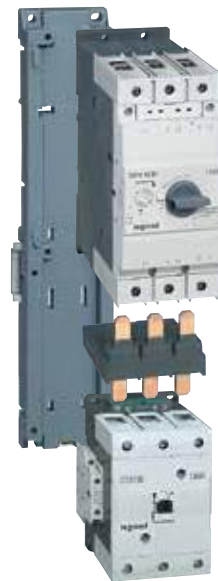

Mini contactors CTX³ 6 to 16 A industrial contactors



4170 00



4170 01

Dimensions p. 48

Conform to IEC 60947-1, 60947-4-1 and 60947-5-1

Pack	Cat.Nos		3-pole mini contactors		
	Integrated auxiliary contact		With integrated auxiliary contact Power terminals: screw terminals		
	1 NO	1 NC	6 A	Max. operating current AC 3	Control Voltage
1	4170 00	4170 10	6 A		24 V \sim
1	4170 01	4170 11	6 A		24 V \equiv
1	4170 04	4170 14	6 A		110 V \sim
1	4170 06	4170 16	6 A		230 V \sim
1	4170 09	4170 19	6 A		415 V \sim
			9 A		
1	4170 20	4170 30	9 A		24 V \sim
1	4170 21	4170 31	9 A		24 V \equiv
1	4170 24	4170 34	9 A		110 V \sim
1	4170 26	4170 36	9 A		230 V \sim
1	4170 29	4170 39	9 A		415 V \sim
			12 A		
1	4170 40	4170 50	12 A		24 V \sim
1	4170 41	4170 51	12 A		24 V \equiv
1	4170 44	4170 54	12 A		110 V \sim
1	4170 46	4170 56	12 A		230 V \sim
1	4170 49	4170 59	12 A		415 V \sim
			16 A		
1	4170 60	4170 70	16 A		24 V \sim
1	4170 61	4170 71	16 A		24 V \equiv
1	4170 64	4170 74	16 A		110 V \sim
1	4170 66	4170 76	16 A		230 V \sim
1	4170 69	4170 79	16 A		415 V \sim
			4-pole mini contactors		
			Without integrated auxiliary contact Power terminals: screw terminals		
			20 A	Max. operating current AC 1	Max. operating current AC 3
1	4171 40		20 A	20 A	16 A
1	4171 41		20 A	20 A	16 A
1	4171 44		20 A	20 A	16 A
1	4171 46		20 A	20 A	16 A
1	4171 49		20 A	20 A	16 A
					Control Voltage
					24 V \sim
					24 V \equiv
					110 V \sim
					230 V \sim
					415 V \sim

Thermal relays and accessories for mini contactors



4170 88



4171 55

Dimensions p. 54
Tripping curves p. 42-45

Pack	Cat.Nos	Thermal overload relays for 3-pole mini contactors
		Class 10A Integrated auxiliary contacts 1 NO + 1 NC
1	4170 80	0.16 A
1	4170 81	0.25 A
1	4170 82	0.40 A
1	4170 83	0.63 A
1	4170 84	1 A
1	4170 85	1.6 A
1	4170 86	2.5 A
1	4170 87	4 A
1	4170 88	6 A
1	4170 89	8 A
1	4170 90	9 A
1	4170 91	10 A
1	4170 92	13 A
1	4170 93	16 A

Pack	Cat.Nos	Add on auxiliary blocks for mini contactors
		I _{th} : 10 A
		Front mounting
15	4171 50	1 NO + 1 NC
15	4171 51	2 NO
15	4171 52	2 NC
15	4171 53	4 NO
15	4171 54	3 NO + 1 NC
15	4171 55	2 NO + 2 NC
15	4171 56	1 NO + 3 NC
15	4171 57	4 NC
		Side mounting
20	4171 58	1 NO
20	4171 59	1 NC

Pack	Cat.Nos	Interlock unit
5	4171 60	Mechanical interlock for mini contactors

Pack	Cat.Nos	Spare coils
10	4171 70	24 V \sim
10	4171 71	24 V \equiv
10	4171 74	110 V \sim
10	4171 76	230 V \sim
10	4171 79	415 V \sim

3-pole contactors CTX³

9 A to 100 A industrial contactors



4160 96 4161 26 4161 46 4161 56 4161 86 4161 96

Technical characteristics and coordination with circuit breakers **p. 26-27**
 Dimensions **p. 54-55**

Conform to IEC 60947-1, IEC 60947-4-1

Can be equipped with RTX³ thermal relays add-on auxiliary contact blocks, time delay blocks, capacitor switching units and CTX³ interlocking

Pack	Cat.Nos	CTX³ 22		
		With integrated auxiliary contacts Power terminals: screw terminals		
		9 A		
	Screw terminals	Max. operating current AC 3	Control Voltage	Integrated auxiliary contacts
1	4160 80	9 A	24 V~	1 NO + 1 NC
1	4160 81	9 A	24 V=	1 NO + 1 NC
1	4160 82	9 A	48 V~	1 NO + 1 NC
1	4160 83	9 A	48 V=	1 NO + 1 NC
1	4160 84	9 A	110 V~	1 NO + 1 NC
1	4160 86	9 A	230 V~	1 NO + 1 NC
1	4160 88	9 A	380 V~	1 NO + 1 NC
1	4160 89	9 A	415 V~	1 NO + 1 NC
		12 A		
1	4160 90	12 A	24 V~	1 NO + 1 NC
1	4160 91	12 A	24 V=	1 NO + 1 NC
1	4160 92	12 A	48 V~	1 NO + 1 NC
1	4160 93	12 A	48 V=	1 NO + 1 NC
1	4160 94	12 A	110 V~	1 NO + 1 NC
1	4160 96	12 A	230 V~	1 NO + 1 NC
1	4160 98	12 A	380 V~	1 NO + 1 NC
1	4160 99	12 A	415 V~	1 NO + 1 NC
		18 A		
1	4161 00	18 A	24 V~	1 NO + 1 NC
1	4161 01	18 A	24 V=	1 NO + 1 NC
1	4161 02	18 A	48 V~	1 NO + 1 NC
1	4161 03	18 A	48 V=	1 NO + 1 NC
1	4161 04	18 A	110 V~	1 NO + 1 NC
1	4161 06	18 A	230 V~	1 NO + 1 NC
1	4161 08	18 A	380 V~	1 NO + 1 NC
1	4161 09	18 A	415 V~	1 NO + 1 NC
		22 A		
1	4161 10	22 A	24 V~	1 NO + 1 NC
1	4161 11	22 A	24 V=	1 NO + 1 NC
1	4161 12	22 A	48 V~	1 NO + 1 NC
1	4161 13	22 A	48 V=	1 NO + 1 NC
1	4161 14	22 A	110 V~	1 NO + 1 NC
1	4161 16	22 A	230 V~	1 NO + 1 NC
1	4161 18	22 A	380 V~	1 NO + 1 NC
1	4161 19	22 A	415 V~	1 NO + 1 NC

Pack	Cat.Nos	CTX³ 40			
		With integrated auxiliary contacts Power terminals: screw terminals			
		32 A			
	Screw terminals	Max. operating current AC 3	Control Voltage	Integrated auxiliary contacts	
1	4161 20	32 A	24 V~	2 NO + 2 NC	
1	4161 21	32 A	24 V=	2 NO + 2 NC	
1	4161 22	32 A	48 V~	2 NO + 2 NC	
1	4161 23	32 A	48 V=	2 NO + 2 NC	
1	4161 24	32 A	110 V~	2 NO + 2 NC	
1	4161 26	32 A	230 V~	2 NO + 2 NC	
1	4161 28	32 A	380 V~	2 NO + 2 NC	
1	4161 29	32 A	415 V~	2 NO + 2 NC	
		40 A			
1	4161 30	40 A	24 V~	2 NO + 2 NC	
1	4161 31	40 A	24 V=	2 NO + 2 NC	
1	4161 32	40 A	48 V~	2 NO + 2 NC	
1	4161 33	40 A	48 V=	2 NO + 2 NC	
1	4161 34	40 A	110 V~	2 NO + 2 NC	
1	4161 36	40 A	230 V~	2 NO + 2 NC	
1	4161 38	40 A	380 V~	2 NO + 2 NC	
1	4161 39	40 A	415 V~	2 NO + 2 NC	
		CTX³ 65			
		With integrated auxiliary contacts			
		50 A			
	Screw terminals	Cage terminals	Max. operating current AC 3	Control Voltage	Integrated auxiliary contacts
1	4161 40	4161 50	50 A	24 V~	2 NO + 2 NC
1	4161 41	4161 51	50 A	24 V=	2 NO + 2 NC
1	4161 42	4161 52	50 A	48 V~	2 NO + 2 NC
1	4161 43	4161 53	50 A	48 V=	2 NO + 2 NC
1	4161 44	4161 54	50 A	110 V~	2 NO + 2 NC
1	4161 46	4161 56	50 A	230 V~	2 NO + 2 NC
1	4161 48	4161 58	50 A	380 V~	2 NO + 2 NC
1	4161 49	4161 59	50 A	415 V~	2 NO + 2 NC
		65 A			
1	4161 60	4161 70	65 A	24 V~	2 NO + 2 NC
1	4161 61	4161 71	65 A	24 V=	2 NO + 2 NC
1	4161 62	4161 72	65 A	48 V~	2 NO + 2 NC
1	4161 63	4161 73	65 A	48 V=	2 NO + 2 NC
1	4161 64	4161 74	65 A	110 V~	2 NO + 2 NC
1	4161 66	4161 76	65 A	230 V~	2 NO + 2 NC
1	4161 68	4161 78	65 A	380 V~	2 NO + 2 NC
1	4161 69	4161 79	65 A	415 V~	2 NO + 2 NC

3-pole contactors CTX³

130 A to 800 A industrial contactors



Technical characteristics and coordination with circuit breakers **p. 26-27**
 Dimensions **p. 49-50**

Conform to IEC 60 947-1, IEC 60 947-4-1
 Can be equipped with RTX³ thermal relays add-on auxiliary contact blocks, time delay blocks (except CTX³ 225/400/800) and CTX³ interlocking

Pack	Cat.Nos		CTX³ 100		
			With integrated auxiliary contacts		
			75 A		
	Screw terminals	Cage terminals	Max. operating current AC 3	Control Voltage	Integrated auxiliary contacts
1	4161 80	4161 90	75 A	24 V~	2 NO + 2 NC
1	4161 81	4161 91	75 A	24 V=	2 NO + 2 NC
1	4161 82	4161 92	75 A	48 V~	2 NO + 2 NC
1	4161 83	4161 93	75 A	48 V=	2 NO + 2 NC
1	4161 84	4161 94	75 A	110 V~	2 NO + 2 NC
1	4161 86	4161 96	75 A	230 V~	2 NO + 2 NC
1	4161 88	4161 98	75 A	380 V~	2 NO + 2 NC
1	4161 89	4161 99	75 A	415 V~	2 NO + 2 NC
			85 A		
1	4162 00	4162 10	85 A	24 V~	2 NO + 2 NC
1	4162 01	4162 11	85 A	24 V=	2 NO + 2 NC
1	4162 02	4162 12	85 A	48 V~	2 NO + 2 NC
1	4162 03	4162 13	85 A	48 V=	2 NO + 2 NC
1	4162 04	4162 14	85 A	110 V~	2 NO + 2 NC
1	4162 06	4162 16	85 A	230 V~	2 NO + 2 NC
1	4162 08	4162 18	85 A	380 V~	2 NO + 2 NC
1	4162 09	4162 19	85 A	415 V~	2 NO + 2 NC
			100 A		
1	4162 20	4162 30	100 A	24 V~	2 NO + 2 NC
1	4162 21	4162 31	100 A	24 V=	2 NO + 2 NC
1	4162 22	4162 32	100 A	48 V~	2 NO + 2 NC
1	4162 23	4162 33	100 A	48 V=	2 NO + 2 NC
1	4162 24	4162 34	100 A	110 V~	2 NO + 2 NC
1	4162 26	4162 36	100 A	230 V~	2 NO + 2 NC
1	4162 28	4162 38	100 A	380 V~	2 NO + 2 NC
1	4162 29	4162 39	100 A	415 V~	2 NO + 2 NC

Pack	Cat.Nos		CTX³ 150		
			With integrated auxiliary contacts		
			130 A		
	Screw terminals	Cage terminals	Max. operating current AC 3	Control Voltage	Integrated auxiliary contacts
1	4162 40	4162 50	130 A	24 V~	2 NO + 2 NC
1	4162 41	4162 51	130 A	24 V=	2 NO + 2 NC
1	4162 42	4162 52	130 A	48 V~	2 NO + 2 NC
1	4162 43	4162 53	130 A	48 V=	2 NO + 2 NC
1	4162 46	4162 56	130 A	100-240 V~/=	2 NO + 2 NC
1	4162 49	4162 59	130 A	400-440 V~/=	2 NO + 2 NC
			150 A		
1	4162 60	4162 70	150 A	24 V~	2 NO + 2 NC
1	4162 61	4162 71	150 A	24 V=	2 NO + 2 NC
1	4162 62	4162 72	150 A	48 V~	2 NO + 2 NC
1	4162 63	4162 73	150 A	48 V=	2 NO + 2 NC
1	4162 66	4162 76	150 A	100-240 V~/=	2 NO + 2 NC
1	4162 69	4162 79	150 A	400-440 V~/=	2 NO + 2 NC

Pack	Cat.Nos		CTX³ 225		
			With integrated auxiliary contacts		
			185 A		
	Screw terminals		Max. operating current AC 3	Control Voltage	Integrated auxiliary contacts
1	4162 80		185 A	24 V~/=	2 NO + 2 NC
1	4162 82		185 A	48 V~/=	2 NO + 2 NC
1	4162 86		185 A	100-240 V~/=	2 NO + 2 NC
1	4162 89		185 A	380-450 V~/=	2 NO + 2 NC
			225 A		
1	4162 90		225 A	24 V~/=	2 NO + 2 NC
1	4162 92		225 A	48 V~/=	2 NO + 2 NC
1	4162 96		225 A	100-240 V~/=	2 NO + 2 NC
1	4162 99		225 A	380-450 V~/=	2 NO + 2 NC
			CTX³ 400		
			With integrated auxiliary contacts		
			265 A		
	Screw terminals		Max. operating current AC 3	Control Voltage	Integrated auxiliary contacts
1	4163 06		265 A	100-240 V~/=	2 NO + 2 NC
1	4163 09		265 A	380-450 V~/=	2 NO + 2 NC
			330 A		
1	4163 16		330 A	100-240 V~/=	2 NO + 2 NC
1	4163 19		330 A	380-450 V~/=	2 NO + 2 NC
			400 A		
1	4163 26		400 A	100-240 V~/=	2 NO + 2 NC
1	4163 29		400 A	380-450 V~/=	2 NO + 2 NC

Pack	Cat.Nos		CTX³ 800		
			With integrated auxiliary contacts		
			500 A		
	Screw terminals		Max. operating current AC 3	Control Voltage	Integrated auxiliary contacts
1	4163 36		500 A	200-240 V~/=	2 NO + 2 NC
1	4163 39		500 A	380-450 V~/=	2 NO + 2 NC
			630 A		
1	4163 46		630 A	200-240 V~/=	2 NO + 2 NC
1	4163 49		630 A	380-450 V~/=	2 NO + 2 NC
			800 A		
1	4163 56		800 A	200-240 V~/=	2 NO + 2 NC
1	4163 59		800 A	380-450 V~/=	2 NO + 2 NC

Thermal relays RTX³

for CTX³ 3-pole industrial contactors



Dimensions **p. 54-55**
 Tripping curves **p. 42-45**

Thermal protection against overloads, long starting times and lasting stalling of the motor
 Differential type ensures a better protection in case of one phase failure thanks to faster tripping
 Conform to IEC 60 947-1, IEC 60 947-4-1

Pack	Cat.Nos		Adjustment range	
	Type standard	Type diff.	I min. (A)	I max. (A)
Thermal overload relays				
Class 10A Integrated auxiliary contacts 1 NO + 1 NC				
RTX³ 40				
For CTX ³ 22 and 40 With screw terminals				
1	4166 40	4166 60	0.1	0.16
1	4166 41	4166 61	0.16	0.25
1	4166 42	4166 62	0.25	0.4
1	4166 43	4166 63	0.4	0.63
1	4166 44	4166 64	0.63	1
1	4166 45	4166 65	1	1.6
1	4166 46	4166 66	1.6	2.5
1	4166 47	4166 67	2.5	4
1	4166 48	4166 68	4	6
1	4166 49	4166 69	5	8
1	4166 50	4166 70	6	9
1	4166 51	4166 71	7	10
1	4166 52	4166 72	9	13
1	4166 53	4166 73	12	18
1	4166 54	4166 74	16	22
1	4166 55	4166 75	18	25
1	4166 56	4166 76	22	32
1	4166 57	4166 77	28	40
RTX³ 65				
For CTX ³ 65 Standard type with screw terminals Differential type with cage terminals				
1	4166 83	4167 03	9	13
1	4166 84	4167 04	12	18
1	4166 85	4167 05	16	22
1	4166 86	4167 06	18	25
1	4166 87	4167 07	24	36
1	4166 88	4167 08	28	40
1	4166 89	4167 09	34	50
1	4166 90	4167 10	45	65

Pack	Cat.Nos		Adjustment range	
	Type standard	Type diff.	I min. (A)	I max. (A)
Thermal overload relays (continued)				
Class 10A Integrated auxiliary contacts 1 NO + 1 NC				
RTX³ 100				
For CTX ³ 100 Standard type with screw terminals Differential type with cage terminals				
1	4167 23	4167 43	18	25
1	4167 24	4167 44	24	36
1	4167 25	4167 45	28	40
1	4167 26	4167 46	34	50
1	4167 27	4167 47	45	65
1	4167 28	4167 48	54	75
1	4167 29	4167 49	63	85
1	4167 30	4167 50	70	95
1	4167 31	4167 51	80	100
RTX³ 150				
For CTX ³ 150 Standard type with screw terminals Differential type with cage terminals				
1	4167 60	4167 70	45	65
1	4167 61	4167 71	54	75
1	4167 62	4167 72	63	85
1	4167 63	4167 73	80	105
1	4167 64	4167 74	95	130
1	4167 65	4167 75	110	150
Separate mounting units				
To mount the relays separately from contactors, on DIN rail or panel by fixing screws				
1	4165 91		For RTX ³ 40 up to 32 A	
1	4165 92		For RTX ³ 40 40 A	
1	4165 93		For RTX ³ 65 with screw terminals	
1	4165 94		For RTX ³ 65 with cage terminals	
1	4165 95		For RTX ³ 100 with screw terminals	
1	4165 96		For RTX ³ 100 with cage terminals	
1	4165 97		For RTX ³ 150 with screw terminals	
1	4165 98		For RTX ³ 150 with cage terminals	

Thermal relays RTX³

for CTX³ 3-pole industrial contactors

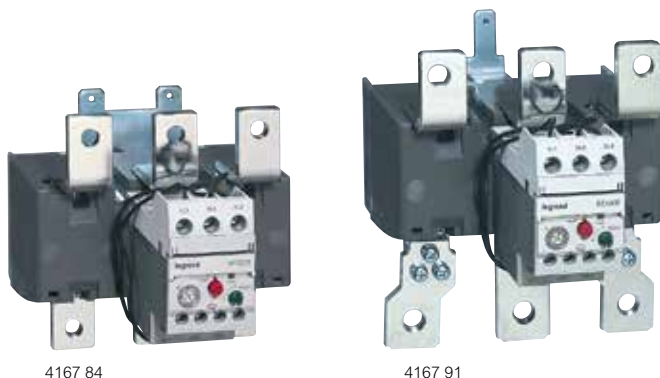

4167 84

4167 91

Dimensions p. 54-55
Tripping curves p. 42-45

Conform to IEC 60 947-1, IEC 60 947-4-1

Pack	Cat.Nos	Thermal overload relays		
		Class 10 A Integrated auxiliary contacts 1 NO + 1 NC		
		RTX³ 225 For CTX ³ 225 With screw terminals		
		Adjustment range		
	Type diff	I min. (A)		I max. (A)
1	4167 80	65		100
1	4167 81	85		125
1	4167 82	100		160
1	4167 83	120		185
1	4167 84	160		240
		RTX³ 400 For CTX ³ 400 With screw terminals		
1	4167 86	85		125
1	4167 87	100		160
1	4167 88	120		185
1	4167 89	160		240
1	4167 90	200		330
1	4167 91	260		400
		RTX³ 800 For CTX ³ 800 With screw terminals		
1	4167 92	200		300
1	4167 93	260		400
1	4167 94	400		630
1	4167 95	520		800

4-pole contactors CTX³

40 A to 900 A industrial contactors and spare coils



4164 36

4164 56

4164 86

Dimensions p. 51-52

Conform to IEC 60 947-1, IEC 60 947-4-1

Can be equipped with add-on auxiliary contact blocks, time delay blocks (except CTX³ 4P from 165 A to 900 A), and CTX³ interlocking

Pack	Cat.Nos	Contactors CTX ³		
		Power terminals: screw terminals		
		Without integrated auxiliary contact		
		Max. operating current AC-1	Max. operating current AC-3	Control Voltage
1	4164 26	40 A	22 A	230 V~
1	4164 36	60 A	40 A	230 V~
1	4164 46	100 A	65 A	230 V~
1	4164 56	135 A	85 A	230 V~
		With integrated auxiliary contacts		
		Auxiliary contacts: 2 NO + 2 NC		
1	4164 66	165 A	130 A	100-240 V~/=
1	4164 76	250 A	150 A	100-240 V~/=
1	4164 86	330 A	225 A	100-240 V~/=
1	4164 96	420 A	330 A	100-240 V~/=
1	4165 06	500 A	400 A	100-240 V~/=
1	4165 16	750 A	630 A	200-240 V~/=
1	4165 26	900 A	800 A	200-240 V~/=
		Spare coils for CTX³ 4P contactors		
		Control voltage 230 V~		
3	4165 46	For CTX ³ 40 A to 60 A (AC-1)		
4	4165 56	For CTX ³ 100 A to 135 A (AC-1)		
1	4165 66	For CTX ³ 165 A to 330 A (AC-1)		
3	4165 76	For CTX ³ 420 A to 500 A (AC-1)		
3	4165 86	For CTX ³ 750 A to 900 A (AC-1)		

CTX³ accessories



4168 50 4168 55 4168 70 4168 79 4168 91 4168 97 4168 40

Technical characteristics **p. 31**
 Dimensions **p. 53**

Pack Cat.Nos CTX³ add-on auxiliary contact blocks

Pack	Cat.Nos	CTX ³ add-on auxiliary contact blocks
		Front mounting
		For CTX ³ 3P from 9 A to 150 A (AC-3) and CTX ³ 4P from 40 A to 135 A (AC-1)
		2 and 4 pole
		Ith: 16 A
20	4168 50	1 NO + 1 NC
20	4168 51	2 NO
20	4168 52	2 NC
10	4168 53	4 NO
10	4168 54	3 NO + 1 NC
10	4168 55	2 NO + 2 NC
10	4168 56	1 NO + 3 NC
10	4168 57	4 NC
		Side mounting
		2-pole
		Mounting on both sides
20	4168 58	For CTX ³ 3P from 9 A to 150 A (AC-3)
		1 NO + 1 NC - Ith: 16 A
50	4168 59	For CTX ³ 3P from 185 A to 800 A (AC-3) and CTX ³ 4P from 165 A to 900 A (AC-1)
		1 NO + 1 NC - Ith: 16 A
60	4168 49	For CTX ³ 4P from 40 A to 135 A (AC-1)
		1 NO + 1 NC - Ith: 16 A

Pack	Cat.Nos	CTX ³ time delay blocks
		For CTX ³ 3P from 9 A to 150 A (AC-3)
		Time delay: 1 to 30 s
		Front mounting
		On delay
1	4168 70	24-48 V \sim /=
1	4168 71	110-230 V \sim
		Off delay
1	4168 72	24-48 V \sim /=
1	4168 73	110-230 V \sim

Pack	Cat.Nos	CTX ³ capacitor switching units
		AC-6b
		Operating power from 9.7 kVAR to 62 kVAR (400/440 V)
1	4168 74	For contactors CTX ³ 3P from 9 to 40 A
1	4168 75	For contactors CTX ³ 3P 50 and 65 A with screw terminals
1	4168 76	For contactors CTX ³ 3P 50 and 65 A with cage terminals
1	4168 77	For contactors CTX ³ 3P 75 to 100 A with screw terminals

Pack Cat.Nos CTX³ interlocking

Pack	Cat.Nos	CTX ³ interlocking
		Component parts for assembling by customer
		Horizontal mounting
		Interlock units
50	4168 79	Mechanical interlocks for CTX ³ 4P from 40 to 135 A (AC-1)
1	4168 80	Mechanical interlocks for CTX ³ 3P from 9 to 150 A
12	4168 87	Provides 2 NC contacts for use in electrical interlocking
		Mechanical interlocks for CTX ³ 3P from 185 to 400 A and CTX ³ 4P from 165 to 500 A
1	4168 88	Mechanical interlocks for CTX ³ 3P from 500 to 800 A
1	4168 89	Mechanical interlocks for CTX ³ 4P from 750 to 900 A
		Wire kits
		Used for making reversing between two 3P contactors
4	4168 82	For CTX ³ 22
6	4168 83	For CTX ³ 40
2	4168 84	For CTX ³ 65
1	4168 85	For CTX ³ 100

Pack	Cat.Nos	Boxes for motor starter
		For CTX ³ 22 equipped with RTX ³ 40 (0.1 - 22 A)
1	4168 90	Without pushbuttons
1	4168 91	With pushbuttons

Pack	Cat.Nos	CTX ³ transient voltage suppressor blocks
		Absorbs the surge arisen out of the coil of the contactor
10	4168 95	24-48 V \sim /=
10	4168 96	100-125 V \sim /=
10	4168 97	200-240 V \sim /=
10	4168 98	380-400 V \sim

Pack	Cat.Nos	CTX ³ terminals covers
10	4168 42	For CTX ³ 3P from 185 to 225 A (AC-3)
25	4168 43	For CTX ³ 3P from 265 to 400 A (AC-3)
5	4168 44	For CTX ³ 3P from 500 to 900 A (AC-3)
10	4168 45	For CTX ³ 4P from 165 to 330 A (AC-1)
10	4168 46	For CTX ³ 4P from 420 to 500 A (AC-1)
5	4168 47	For CTX ³ 4P from 750 to 900 A (AC-1)

Pack	Cat.Nos	CTX ³ safety front cover
150	4168 40	For CTX ³ 3P from 9 to 150 A (AC-3) and CTX ³ 4P from 40 to 135 A (AC-1)
150	4168 41	For CTX ³ 3P from 85 to 800 A (AC-3) and CTX 4P from 165 to 900 A (AC-1)

Pack	Cat.Nos	Distant reset flexible cables for thermal relays
1	4168 92	400 mm
1	4168 93	500 mm
1	4168 94	600 mm



4169 66



4168 10

Spare coils for CTX³ 3P contactors

Pack	Cat.Nos
For CTX³ 22	
4	4169 00 24 V~
4	4169 02 48 V~
4	4169 04 110 V~
4	4169 06 230 V~
4	4169 08 380 V~
4	4169 09 415 V~
For CTX³ 40	
6	4169 20 24 V~
6	4169 21 24 V=
6	4169 22 48 V~
6	4169 23 48 V=
6	4169 24 110 V~
6	4169 26 230 V~
6	4169 28 380 V~
6	4169 29 415 V~
For CTX³ 65	
4	4169 30 24 V~
2	4169 31 24 V=
4	4169 32 48 V~
2	4169 33 48 V=
4	4169 34 110 V~
4	4169 36 230 V~
4	4169 38 380 V~
4	4169 39 415 V~
For CTX³ 100	
3	4169 40 24 V~
2	4169 41 24 V=
3	4169 42 48 V~
2	4169 43 48 V=
3	4169 44 110 V~
3	4169 46 230 V~
3	4169 48 380 V~
3	4169 49 415 V~
For CTX³ 150	
2	4169 50 24 V~
2	4169 51 24 V=
2	4169 52 48 V~
2	4169 53 48 V=
2	4169 56 100-240 V~/=
2	4169 59 400-440 V~
For CTX³ 225	
1	4169 60 24 V~/=
1	4169 62 48 V~/=
1	4169 66 100-240 V~/=
1	4169 69 400-440 V~
For CTX³ 400	
3	4169 76 100-240 V~/=
3	4169 79 380-450 V~
For CTX³ 400	
3	4169 86 200-240 V~/=
3	4169 89 380-450 V~

Dimensions p. 54

Pack	Cat.Nos	CTX ³ control relays
4-pole Conform to IEC 60 947-1, IEC 60 947-4-1 and IEC 60 947-5-1 for the auxiliary contacts Can be equipped with CTX ³ mini I _{th} = 10 A Low consumption coil		
4 NO		
1	4168 00	24 V~
1	4168 01	24 V=
1	4168 02	48 V~
1	4168 03	48 V=
1	4168 04	110 V~
1	4168 06	230 V~
1	4168 09	400 V~
3 NO + 1 NC		
1	4168 10	24 V~
1	4168 11	24 V=
1	4168 12	48 V~
1	4168 13	48 V=
1	4168 14	110 V~
1	4168 16	230 V~
1	4168 19	400 V~
2 NO + 2 NC		
1	4168 20	24 V~
1	4168 21	24 V=
1	4168 22	48 V~
1	4168 23	48 V=
1	4168 24	110 V~
1	4168 26	230 V~
1	4168 29	400 V~

MPCBs MPX³

motor protection circuit breakers from 0.16 A to 100 A



Technical characteristics and tripping curves p. 32, 40-41
 Dimensions and wiring capacity chart p. 55-56

Conform to IEC 60 947-1, IEC 60 947-2, IEC 60 947-4

Pack	Cat.Nos	Thermal magnetic MPCBs			
		Adjustable thermal release Magnetic release 13 le max. MPX³ 32S Standard breaking capacity With toggle handle Fixing on rail			
		Rated 3 Ph Motor	Thermal release adjustment range (A)	Magnetic release operating current (A)	415 V breaking capacity Icu (kA)
	3P				
1	4173 00	0.02	0.1 to 0.16	2.1	100
1	4173 01	0.06	0.16 to 0.25	3.3	100
1	4173 02	0.09	0.25 to 0.4	5.2	100
1	4173 03	0.12	0.4 to 0.63	8.2	100
1	4173 04	0.18 / 0.25	0.63 to 1	13	100
1	4173 05	0.37 / 0.55	1 to 1.6	20.8	100
1	4173 06	0.75	1.6 to 2.5	32.5	100
1	4173 07	1.5	2.5 to 4	52	100
1	4173 08	2.2	4 to 6	78	100
1	4173 09	3	5 to 8	104	100
1	4173 10	4	6 to 10	130	50
1	4173 11	5.5	9 to 13	169	50
1	4173 12	7.5	11 to 17	221	20
1	4173 13	7.5	14 to 22	286	15
1	4173 14	11	18 to 26	338	15
1	4173 15	15	22 to 32	416	15
		MPX³ 32H High breaking capacity With rotary handle Fixing on rail			
1	4173 20	0.02	0.1 to 0.16	2.1	100
1	4173 21	0.06	0.16 to 0.25	3.3	100
1	4173 22	0.09	0.25 to 0.4	5.2	100
1	4173 23	0.12	0.4 to 0.63	8.2	100
1	4173 24	0.18 / 0.25	0.63 to 1	13	100
1	4173 25	0.37 / 0.55	1 to 1.6	20.8	100
1	4173 26	0.75	1.6 to 2.5	32.5	100
1	4173 27	1.5	2.5 to 4	52	100
1	4173 28	2.2	4 to 6	78	100
1	4173 29	3	5 to 8	104	100
1	4173 30	4	6 to 10	130	100
1	4173 31	5.5	9 to 13	169	100
1	4173 32	7.5	11 to 17	221	50
1	4173 33	7.5	14 to 22	286	50
1	4173 34	11	18 to 26	338	50
1	4173 35	15	22 to 32	416	50
		MPX³ 63H High breaking capacity With rotary handle Fixing on rail or by screw			
1	4173 60	4	6 to 10	130	100
1	4173 61	5.5	9 to 13	169	100
1	4173 62	7.5	11 to 17	221	50
1	4173 63	7.5	14 to 22	286	50
1	4173 64	11	18 to 26	338	50
1	4173 65	15	22 to 32	416	50
1	4173 66	18.5	28 to 40	520	50
1	4173 67	22	34 to 50	650	50
1	4173 68	30	45 to 63	819	50

Pack	Cat.Nos	Thermal magnetic MPCBs (continued)			
		MPX³ 100H High breaking capacity With rotary handle Fixing on rail or by screw			
		Rated 3 Ph Motor	Thermal release adjustment range (A)	Magnetic release operating current (A)	415 V breaking capacity Icu (kA)
	3P				
1	4173 70	7.5	11 to 17	221	100
1	4173 71	7.5	14 to 22	286	100
1	4173 72	11	18 to 26	338	100
1	4173 73	15	22 to 32	416	100
1	4173 74	18.5	28 to 40	520	100
1	4173 75	22	34 to 50	650	100
1	4173 76	30	45 to 63	819	100
1	4173 77	37	55 to 75	975	75
1	4173 78	45	70 to 90	1170	75
1	4173 79	45	80 to 100	1300	75
		Magnetic only MPCBs Without thermal release Magnetic release 13 x le max. MPX³ 32MA High breaking capacity With rotary handle Fixing on rail			
		Rated 3 Ph Motor	Magnetic release operating current (A)	415 V breaking capacity Icu (kA)	
	3P				
1	4173 40	0.02	2.1	100	
1	4173 41	0.06	3.3	100	
1	4173 42	0.09	5.2	100	
1	4173 43	0.12	8.2	100	
1	4173 44	0.18 / 0.25	13	100	
1	4173 45	0.37 / 0.55	20.8	100	
1	4173 46	0.75	32.5	100	
1	4173 47	1.5	52	100	
1	4173 48	2.2	78	100	
1	4173 49	3	104	100	
1	4173 50	4	130	100	
1	4173 51	5.5	169	100	
1	4173 52	7.5	221	50	
1	4173 53	7.5	286	50	
1	4173 54	11	338	50	
1	4173 55	15	416	50	

MPCBs MPX³

accessories

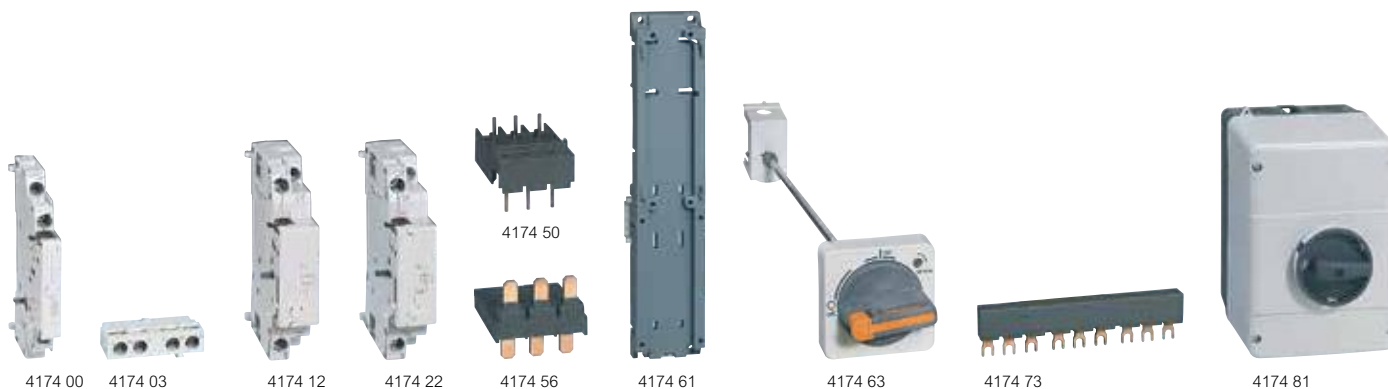

Pack	Cat.Nos	Auxiliary contacts	Pack	Cat.Nos	Direct adaptator and mounting unit
		2-pole			For mounting CTX ³ contactors under MPX ³ MPCBs
		Side mounting			Direct adaptators
		Mounting on the left side of MPCBs			Used to connect MPX ³ directly with the contactor
		Two auxiliary contacts per MPCB	2	4174 40	For MPX ³ 32S with CTX ³ mini AC
2	4174 00	1 NO + 1 NC	2	4174 41	For MPX ³ 32S with CTX ³ mini DC
2	4174 01	2 NO	2	4174 42	For MPX ³ 32H/32MA with CTX ³ mini AC
2	4174 02	2 NC	2	4174 43	For MPX ³ 32H/32MA with CTX ³ mini DC
		Front mounting	2	4174 48	For MPX ³ 32S with CTX ³ 22 AC
		One auxiliary contact per MPCB	2	4174 49	For MPX ³ 32S with CTX ³ 22 DC
10	4174 03	1 NO + 1 NC	2	4174 50	For MPX ³ 32H/32MA with CTX ³ 22 AC
10	4174 04	2 NO	2	4174 51	For MPX ³ 32H/32MA with CTX ³ 22 DC
10	4174 05	2 NC	2	4174 52	For MPX ³ 32S with CTX ³ 40 AC
		Alarm contacts	2	4174 53	For MPX ³ 32S with CTX ³ 40 DC
		1 NO + 1 NC	2	4174 54	For MPX ³ 32H/32MA with CTX ³ 40 AC
		Any trip alarm contact	2	4174 55	For MPX ³ 32H/32MA with CTX ³ 40 DC
		Operate in case of trip	2	4174 56	For MPX ³ 63H with CTX ³ 65 AC with cage type terminals
		Mounting on the left side of MPCBs	2	4174 57	For MPX ³ 63H with CTX ³ 65 DC with cage type terminals
		Set alarm contact first in case of using auxiliary contact together (MPX ³ 63H can not accept auxiliary contact and alarm contact together)	1	4174 58	For MPX ³ 100H with CTX ³ 100 AC with cage type terminals
1	4174 06	For MPX ³ 32	1	4174 59	For MPX ³ 100H with CTX ³ 100 DC with cage type terminals
1	4174 08	For MPX ³ 63 and 100			Mounting unit
		Magnetic trip alarm contact			This device is used for joining together MPX ³ MCPBs and CTX ³ contactors
		Operate in case of instantaneous trip			Screws not supplied
		Mounting on the left side of MPCBs	1	4174 60	For MPX ³ 32S/32H/32MA
		Set alarm contact first in case of using auxiliary contact together	1	4174 61	For MPX ³ 63H
2	4174 07	1 NO + 1 NC	1	4174 62	For MPX ³ 100H
		Shunt release			Rotary handle
		Mounting on the right side of MPCBs			Mounting on panel's door to control the MPX ³
		One release per MPCB	1	4174 63	For MPX ³ 32H and 32 MA
1	4174 10	24 V - 50 Hz / 28 V - 60 Hz	1	4174 64	For MPX ³ 63H
1	4174 11	110 V - 50 Hz / 120 V - 60 Hz	1	4174 65	For MPX ³ 100H
1	4174 12	220-230 V - 50 Hz / 240-260 V - 60 Hz			Phase busbar
1	4174 13	380-400 V - 50 Hz / 440-460 V - 60 Hz			For parallel connection of MPX ³
		Undervoltage release			For MPX³ 32S, 32H and 32MA
		Mounting on the right side of MPCBs			Rated current 63 A
		One release per MPCB	10	4174 71	2 devices
		Without auxiliary contact	10	4174 73	3 devices
1	4174 20	24 V - 50 Hz / 28 V - 60 Hz	10	4174 75	4 devices
1	4174 21	110 V - 50 Hz / 120 V - 60 Hz	10	4174 76	5 devices
1	4174 22	220-230 V - 50 Hz / 240-260 V - 60 Hz	4	4174 77	Feeder for phase busbar 32 A
1	4174 23	380-400 V - 50 Hz / 440-460 V - 60 Hz			For MPX³ 63H
		With 2 NO auxiliary contacts			Rated current 108 A
		Can not attach to MPX ³ 32S	4	4174 72	2 devices
1	4174 30	24 V - 50 Hz / 28 V - 60 Hz	4	4174 74	3 devices
1	4174 31	110 V - 50 Hz / 120 V - 60 Hz			Enclosures for MPX³ 32H and 32MA
1	4174 32	220-230 V - 50 Hz / 240-260 V - 60 Hz			IP 65 enclosure to use in dusty areas as well as in presence of corrosive gas or liquid
1	4174 33	380-400 V - 50 Hz / 440-460 V - 60 Hz			Yellow/red with rotary handle
		Dial cover			With black rotary handle
		Sealable cover to protect the set value from the operation that is not intended	1	4174 80	
100	4174 79	For all types of MPX ³	1	4174 81	

DMX³
AIR CIRCUIT BREAKERS

Optimized performance up to 6300 A

DMX³ air circuit breakers are available in three frame sizes for three breaking capacities: 50 kA for the DMX³ N designation, 65 kA for DMX³ H and 100 kA for DMX³ L.



The range covers 11 rated currents, between 630 A and 6300 A.

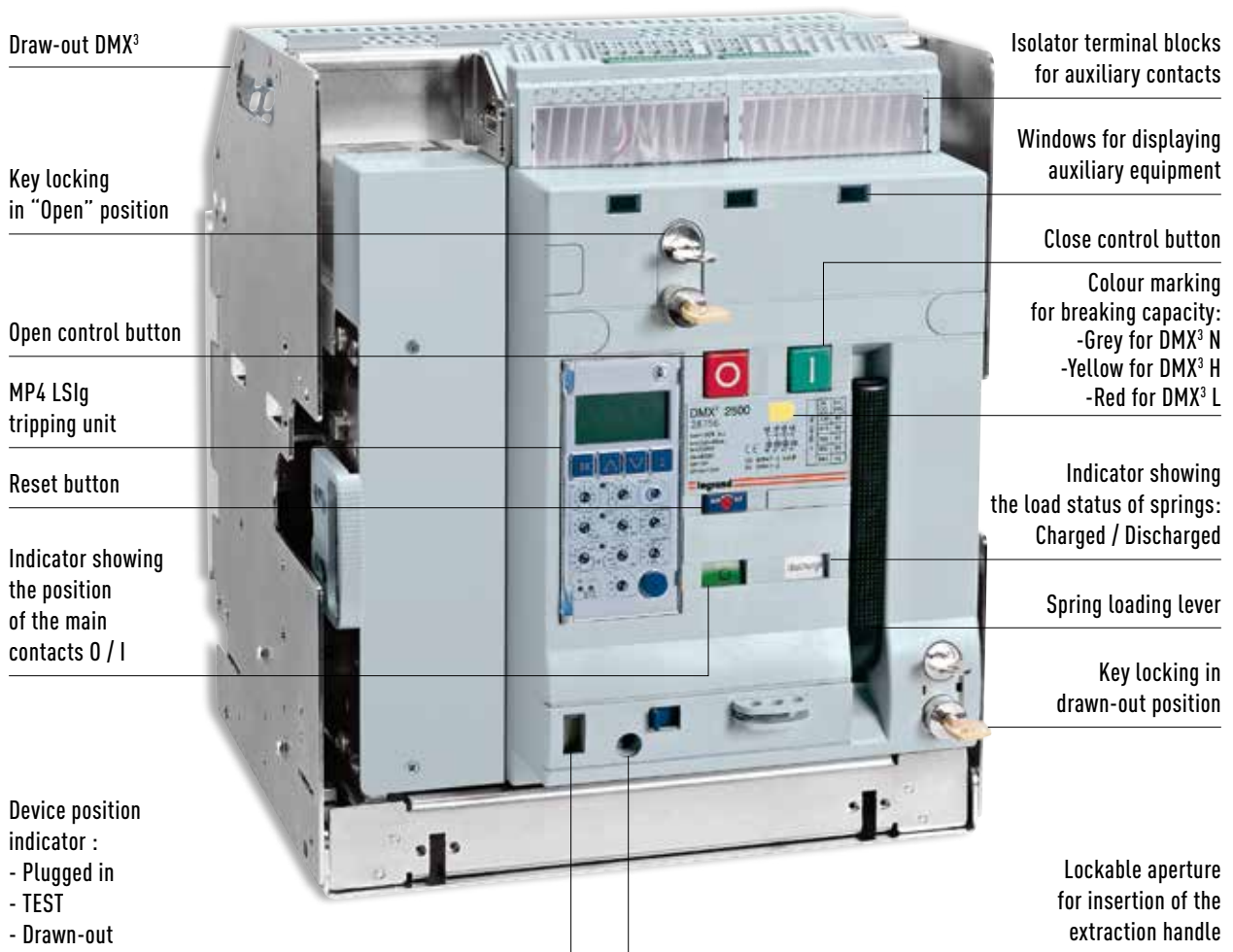

All range of DMX³ air circuit breakers is available in fixed and draw-out version.











3-pole contactors CTX³ and thermal overload relays RTX³

technical characteristics

												
Contactor		CTX ³ mini				CTX ³ 22				CTX ³ 40		
	Size	-				2				3		
	Terminals type	screw				screw				screw		
	Rated operational voltage, U _e	690 V				690 V				690 V		
	Rated insulation voltage, U _i	690 V				690 V				1000 V		
	Rated frequency	50/60 Hz				50/60 Hz				50/60 Hz		
	Rated impulse withstand voltage, U _{imp}	6 kV				6 kV				8 kV		
	Max. operating rate in operation cycle per hour (AC-3)	1800				1200				1800		
Durability in millions of operations	Mechanical	12				15				12		
	Electrical	1				2.5				2		
	Type	6 A	9 A	12 A	16 A	9 A	12 A	18 A	22 A	32 A	40 A	
Current and power	AC-1	Thermal current (A)	20	20	20	20	25	25	40	40	50	60
		200/240 V (kW)	1.5	2.2	3	4	2.5	3.5	4.5	5.5	7.5	11
		(A)	7	9	12	15	11	13	18	22	32	40
	380/440 V (kW)		2.2	4	5.5	7.5	4	5.5	7.5	11	15	18.5
		(A)	6	9	12	16	9	12	18	22	32	40
	500/550 V (kW)		3	3.7	4	5.5	4	7.5	7.5	15	18.5	22
		(A)	5	6	7	9	7	12	13	20	28	32
	690 V (kW)		3	4	4	4	4	7.5	7.5	15	18.5	22
		(A)	4	5	5	5	5	9	9	18	20	23
	UL rating 50/60 Hz	Continuous current (A)		20	20	20	20	25	25	40	40	50
Single phase			110/220 V (HP)	1/2	1/2	1	-	0.5	0.75	1	2	2
		220/240 V (HP)	1	1.5	2	-	1.5	2	3	3	5	7.5
Three phase		200/208 V (HP)	-	-	-	-	2	3	5	7.5	7.5	15
		220/240 V (HP)	1.5	3	3	-	3	5	7.5	10	10	15
		440/480 V (HP)	3	5	7.5	-	5	7.5	10	15	20	30
		550/600 V (HP)	3	5	7.5	-	7.5	10	15	20	25	30
		NEMA size	00	00	00	0	00	00	0	1	1	1
Weight and size	AC control	Weight (kg)	0.17				0.34				0.4	
		Size (W x H x D) (mm)	45 x 58 x 57				45 x 73.5 x 87.4				45 x 83 x 90	
	DC control	Weight (kg)	0.23				0.41				0.6	
		Size (W x H x D) (mm)	45 x 58 x 69				45 x 73.5 x 103.6				45 x 83 x 117.1	
	Integrated auxiliary contacts	1 NO or 1 NC				1 NO + 1 NC				2 NO + 2 NC		
Add on auxiliary block	Side mounting	Yes				Yes				Yes		
	Front mounting	Yes				Yes				Yes		

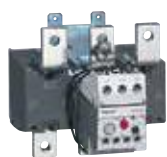
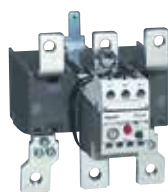
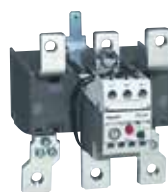

Thermal overload relay											
		RTX ³ mini				RTX ³ 40				RTX ³ 40	
Terminals type	Standard RTX ³	screw				screw				screw	
	Differential RTX ³	screw				screw				screw	
	Rated operational voltage, U _e	690 V				690 V				690 V	
	Rated insulation voltage, U _i	690 V				690 V				690 V	
	Rated impulse withstand voltage, U _{imp}	6 kV				6 kV				6 kV	
	Trip class	10 A				10 A				10 A	
	Setting	0.1 to 16 A				0.1 to 40 A				0.1 to 40 A	
Weight and size	Weight (kg)	0.1				0.17				0.17	
	Size (W x H x D) (mm)	45 x 73 x 63				45 x 75 x 90				45 x 75 x 90	

														
CTX³ 65		CTX³ 100			CTX³ 150		CTX³ 225		CTX³ 400			CTX³ 800		
4		5			6		7		8			9		
screw or cage		screw or cage			screw or cage		screw		screw			screw		
690 V		690 V			690 V		690 V		690 V			690 V		
1000 V		1000 V			1000 V		1000 V		1000 V			1000 V		
50/60 Hz		50/60 Hz			50/60 Hz		50/60 Hz		50/60 Hz			50/60 Hz		
8 kV		8 kV			8 kV		8 kV		8 kV			8 kV		
1800		1800			1200		1200		1200			1200		
12		12			5		5		5			2.5		
2		2			1		1		1			0.5		
50 A	65 A	75 A	85 A	100 A	130 A	150 A	185 A	225 A	265 A	330 A	400 A	500 A	630 A	800 A
70	100	110	135	160	160	210	230	275	300	350	450	580	660	900
15	18.5	22	25	30	37	45	55	75	80	90	125	147	190	220
55	65	75	85	105	130	150	185	225	265	330	400	500	630	800
22	30	37	45	55	60	75	90	132	147	160	200	265	330	440
50	65	75	85	105	130	150	185	225	265	330	400	500	630	800
30	33	37	45	55	60	70	110	132	147	160	225	265	330	500
43	60	64	75	85	90	100	180	200	225	280	350	400	500	720
30	33	37	45	55	55	55	110	140	160	200	250	300	400	500
28	35	42	45	65	60	60	120	150	185	225	300	380	420	630
70	100	110	135	160	160	210	230	275	300	350	450	580	660	900
3	5	5	7.5	10	10	15	15	15	-	-	-	-	-	-
10	15	15	15	20	20	25	30	40	-	-	-	-	-	-
20	25	25	30	30	40	40	60	60	75	100	125	150	200	200
25	30	30	40	40	40	50	60	75	100	125	150	200	250	300
40	50	50	60	75	75	100	125	150	200	250	300	400	500	600
50	60	60	75	75	75	75	125	150	200	250	300	400	500	600
2	2	2	3	3	3	4	4	4	5	5	5	6	6	7
0.9		1.6			2.4		5.4		9.2			22.4		
55 × 106 × 119		70 × 140 × 135.8			95 × 158 × 130.3		138 × 203 × 185.1		163 × 243 × 204.4			285 × 312 × 245.3		
1.2		2.6			2.4		5.4		9.2			22.4		
55 × 106 × 146.4		70 × 140 × 172.3			95 × 158 × 130.3		138 × 203 × 185.1		163 × 243 × 204.4			285 × 312 × 245.3		
2 NO + 2 NC		2 NO + 2 NC			2 NO + 2 NC		2 NO + 2 NC		2 NO + 2 NC			2 NO + 2 NC		
Yes		Yes			Yes		Yes		Yes			Yes		
Yes		Yes			Yes		No		No			No		

														
RTX³ 65		RTX³ 100			RTX³ 150		RTX³ 225		RTX³ 400			RTX³ 800		
screw		screw			screw		screw		screw			screw		
cage		cage			cage		screw		screw			screw		
690 V		690 V			690 V		690 V		690 V			690 V		
690 V		690 V			690 V		690 V		690 V			690 V		
6 kV		6 kV			6 kV		6 kV		6 kV			6 kV		
10 A		10 A			10 A		10 A		10 A			10 A		
9 to 65 A		18 to 100 A			45 to 150 A		65 to 240 A		85 to 400 A			200 to 800 A		
0.31/0.33		0.48/0.5			0.67		2.5		2.6			11.5		
55 × 81 × 100		70 × 97 × 110			95 × 109 × 113		147 × 141 × 184		151 × 171 × 198			360 × 530 × 212		

MPCBs MPX³

technical characteristics

																						
MPCB		MPX³ 32S										MPX³ 32H										
	Size	1										2										
	Type	Thermal magnetic										Thermal magnetic										
	Breaking capacity	Standard										High										
	Handle type	Toggle										Rotary										
	Number of poles	3										3										
Characteristics of use																						
	Rated operational voltage (Ue)	Up to 690 V										Up to 690 V										
	Rated frequency	50/60 Hz										50/60 Hz										
	Rated insulation voltage (Ui)	690 V										690 V										
	Rated impulse voltage (Uimp)	6 kV										6 kV										
Utilisation category	IEC 60947-2 (breaker)	Cat. A										Cat. A										
	IEC 60947-4 (Motor starter)	AC3										AC3										
	Mechanical endurance (Operating)	100000										100000										
	Electric endurance (Cycles)	100000										100000										
	Max operating frequency per hour (Ope./h)	25										25										
	Temperature compensation	-20 to + 60 °C										-20 to + 60 °C										
	Instantaneous short circuit release	13 x Ie max.										13 x Ie max.										
	Trip class	•										10										
	Overload protection	•										•										
	Phase failure protection	•										•										
	Trip indicating function	with alarm contact 4174 06/07										with alarm contact 4174 06/07										
	Test function	•										•										
	Weight (g)	320										360										
Rated breaking capacity (kA)	Rated operational current Ie (A)	Thermal release adjustment range (A)	240 V		415 V		460 V		525 V		690 V		240 V		415 V		460 V		525 V		690 V	
			230 V	220 V	400 V	440 V	500 V	600 V	230 V	220 V	400 V	440 V	500 V	600 V	400 V	440 V	500 V	600 V	400 V	440 V	500 V	600 V
			Icu	Ics	Icu	Ics	Icu	Ics	Icu	Ics	Icu	Ics	Icu	Ics	Icu	Ics	Icu	Ics	Icu	Ics	Icu	Ics
	0.16	0.1 to 0.16	100	100	100	100	100	100	100	100	100	100	100	100	100	100	100	100	100	100	100	100
	0.25	0.16 to 0.25	100	100	100	100	100	100	100	100	100	100	100	100	100	100	100	100	100	100	100	100
	0.4	0.25 to 0.4	100	100	100	100	100	100	100	100	100	100	100	100	100	100	100	100	100	100	100	100
	0.63	0.4 to 0.63	100	100	100	100	100	100	100	100	100	100	100	100	100	100	100	100	100	100	100	100
	1	0.63 to 1	100	100	100	100	100	100	100	100	100	100	100	100	100	100	100	100	100	100	100	100
	1.6	1 to 1.6	100	100	100	100	100	100	100	100	3	3	100	100	100	100	100	100	100	100	100	100
	2.5	1.6 to 2.5	100	100	100	100	100	100	50	38	3	3	100	100	100	100	100	100	100	100	8	8
	4	2.5 to 4	100	100	100	100	50	38	15	11	3	3	100	100	100	100	100	100	100	100	8	8
	6	4 to 6	100	100	100	100	15	11	10	8	3	3	100	100	100	100	100	100	100	100	6	6
	8	5 to 8	100	100	100	100	15	11	10	8	3	3	100	100	100	100	50	38	50	38	6	6
	10	6 to 10	100	100	50	38	15	11	6	5	3	3	100	100	100	100	50	38	50	38	6	6
	13	9 to 13	100	100	50	38	10	8	6	5	3	3	100	100	100	100	50	38	42	32	6	6
	17	11 to 17	50	38	20	15	10	8	6	5	3	3	100	100	50	38	20	15	10	8	4	4
	22	14 to 22	40	30	15	11	8	6	6	5	3	3	100	100	50	38	20	15	10	8	4	4
	26	18 to 26	40	30	15	11	8	6	5	4	3	3	100	100	50	38	20	15	10	8	4	4
	32	22 to 32	30	22	15	11	6	4	5	4	3	3	100	100	50	38	20	15	10	8	4	4
	40	28 to 40	-	-	-	-	-	-	-	-	-	-	-	-	-	-	-	-	-	-	-	-
	50	34 to 50	-	-	-	-	-	-	-	-	-	-	-	-	-	-	-	-	-	-	-	-
	63	45 to 63	-	-	-	-	-	-	-	-	-	-	-	-	-	-	-	-	-	-	-	-
	75	55 to 75	-	-	-	-	-	-	-	-	-	-	-	-	-	-	-	-	-	-	-	-
	90	70 to 90	-	-	-	-	-	-	-	-	-	-	-	-	-	-	-	-	-	-	-	-
	100	80 to 100	-	-	-	-	-	-	-	-	-	-	-	-	-	-	-	-	-	-	-	-



MPX³ 32MA

MPX³ 63H

MPX³ 100H

2
Magnetic only
High
Rotary
3

3
Thermal magnetic
High
Rotary
3

4
Thermal magnetic
High
Rotary
3

Up to 690 V
50/60 Hz
690 V
6 kV
Cat. A
AC3
100000
100000
25
-20 to + 60 °C
13 x I_e max.

Up to 690 V
50/60 Hz
1000 V
8 kV
Cat. A
AC3
50000
25000
25
-20 to + 60 °C
13 x I_e max.

Up to 690 V
50/60 Hz
1000 V
8 kV
Cat. A
AC3
50000
25000
25
-20 to + 60 °C
13 x I_e max.

with alarm contact 4174 06/07

with alarm contact 4174 07/08

with alarm contact 4174 07/08

360

1000

2200

	240 V 230 V 220 V	415 V 400 V	460 V 440 V	525 V 500 V	690 V 600 V	240 V 230 V 220 V	415 V 400 V	460 V 440 V	525 V 500 V	690 V 600 V	240 V 230 V 220 V	415 V 400 V	460 V 440 V	525 V 500 V	690 V 600 V
--	-------------------------	----------------	----------------	----------------	----------------	-------------------------	----------------	----------------	----------------	----------------	-------------------------	----------------	----------------	----------------	----------------

	Icu	Ics	Icu	Ics	Icu	Ics	Icu	Ics	Icu	Ics	Icu	Ics	Icu	Ics	Icu	Ics	Icu	Ics	Icu	Ics	Icu	Ics	Icu	Ics	Icu	Ics	Icu	Ics		
	100	100	100	100	100	100	100	100	100	100	-	-	-	-	-	-	-	-	-	-	-	-	-	-	-	-	-	-		
	100	100	100	100	100	100	100	100	100	100	-	-	-	-	-	-	-	-	-	-	-	-	-	-	-	-	-	-		
	100	100	100	100	100	100	100	100	100	100	-	-	-	-	-	-	-	-	-	-	-	-	-	-	-	-	-	-		
	100	100	100	100	100	100	100	100	100	100	-	-	-	-	-	-	-	-	-	-	-	-	-	-	-	-	-	-		
	100	100	100	100	100	100	100	100	100	100	-	-	-	-	-	-	-	-	-	-	-	-	-	-	-	-	-	-		
	100	100	100	100	100	100	100	100	100	100	-	-	-	-	-	-	-	-	-	-	-	-	-	-	-	-	-	-		
	100	100	100	100	100	100	100	100	100	8	8	-	-	-	-	-	-	-	-	-	-	-	-	-	-	-	-	-		
	100	100	100	100	100	100	100	100	8	8	-	-	-	-	-	-	-	-	-	-	-	-	-	-	-	-	-	-		
	100	100	100	100	100	100	100	6	6	6	6	-	-	-	-	-	-	-	-	-	-	-	-	-	-	-	-	-		
	100	100	100	100	50	38	50	38	6	6	-	-	-	-	-	-	-	-	-	-	-	-	-	-	-	-	-	-		
	100	100	100	100	50	38	50	38	6	6	100	100	100	100	50	38	50	38	6	5	-	-	-	-	-	-	-	-		
	100	100	100	100	50	38	42	32	6	6	100	100	100	100	50	38	42	32	6	5	-	-	-	-	-	-	-	-		
	100	100	50	38	20	15	10	8	4	4	100	100	50	50	50	38	12	9	5	5	100	100	100	100	50	38	35	27	12	9
	100	100	50	38	20	15	10	8	4	4	100	100	50	50	50	38	12	9	5	5	100	100	100	50	50	38	35	27	12	9
	100	100	50	38	20	15	10	8	4	4	100	100	50	50	35	27	12	9	5	5	100	100	100	50	50	38	35	27	12	9
	100	100	50	38	20	15	10	8	4	4	100	100	50	50	35	27	10	8	5	5	100	100	100	50	50	38	25	19	12	9
	-	-	-	-	-	-	-	-	-	-	100	100	50	50	35	27	10	8	5	5	100	100	100	50	50	38	20	15	12	9
	-	-	-	-	-	-	-	-	-	-	100	100	50	50	35	27	10	8	5	5	100	100	100	50	50	38	15	11	10	8
	-	-	-	-	-	-	-	-	-	-	100	100	50	50	35	27	10	8	5	5	100	100	100	50	50	38	15	11	8	6
	-	-	-	-	-	-	-	-	-	-	-	-	-	-	-	-	-	-	-	-	100	100	75	50	50	38	12	9	6	6
	-	-	-	-	-	-	-	-	-	-	-	-	-	-	-	-	-	-	-	-	100	100	75	50	50	38	12	9	6	6
	-	-	-	-	-	-	-	-	-	-	-	-	-	-	-	-	-	-	-	-	100	100	75	50	50	38	12	9	6	6

Contactors CTX³

technical characteristics

Environmental conditions

- Storage temperature: -50 °C to + 80 °C
- Operating temperature: -5 °C to + 50 °C
- Operating altitude: 3000 m
- Protection degree: IP 20
- Shock resistance: open 8 G / closed 10 G
- Vibration resistance (5-300 Hz): open 2 G / closed 4 G

Type 2 coordination with MPCBs MPX³

According to IEC 60 947-4-1
Short circuit current I_q = 50 kA Voltage 400/415 V~ 50/60 Hz

Standard motors AC-3 at 400/415 V 1500 rpm		Manual motor starter			Contactor		
Rated Power (kW)	Current (A)	MPCB type		Thermal overload release setting range (A)	Magnetic release response current (A)	Contactor	
		Type	Rating (A)			Type	Rating (A)
-	-	MPX ³ 32S	0.16	0.1 - 0.16	2.08	CTX ³ 22	9
0.06	0.20	MPX ³ 32S	0.25	0.16 - 0.25	3.25	CTX ³ 22	9
0.09	0.30	MPX ³ 32S	0.40	0.25 - 0.4	5.2	CTX ³ 22	9
0.12	0.40	MPX ³ 32S	0.63	0.4 - 0.63	8.19	CTX ³ 22	9
0.18	0.60	MPX ³ 32S	0.63	0.4 - 0.63	8.19	CTX ³ 22	9
0.25	0.80	MPX ³ 32S	1	0.63 - 1	13	CTX ³ 22	9
0.37	1.1	MPX ³ 32S	1.6	1 - 1.6	20.8	CTX ³ 22	9
0.55	1.5	MPX ³ 32S	1.6	1 - 1.6	20.8	CTX ³ 22	9
0.75	1.9	MPX ³ 32S	2.5	1.6 - 2.5	32.5	CTX ³ 22	12
1.1	2.7	MPX ³ 32S	4	2.5 - 4	52	CTX ³ 22	18
1.5	3.6	MPX ³ 32S	4	2.5 - 4	52	CTX ³ 22	18
2.2	5.2	MPX ³ 32S	6	4 - 6	78	CTX ³ 22	18
3	6.8	MPX ³ 32S	8	5 - 8	104	CTX ³ 22	18
4	9	MPX ³ 32S	10	6 - 10	130	CTX ³ 22	18
5.5	11.5	MPX ³ 32H	13	9 - 13	169	CTX ³ 22	22
7.5	15.5	MPX ³ 32H	17	11 - 17	221	CTX ³ 22	22
10	20	MPX ³ 32H	22	14 - 22	286	CTX ³ 40	32
11	22	MPX ³ 32H	25	18 - 26	338	CTX ³ 40	32
15	29	MPX ³ 32H	32	22 - 32	416	CTX ³ 40	32
18.5	35	MPX ³ 63H	40	28 - 40	520	CTX ³ 65	50
22	41	MPX ³ 63H	50	34 - 50	650	CTX ³ 65	50
30	55	MPX ³ 63H	63	45 - 63	819	CTX ³ 65	65
37	67	MPX ³ 100H	75	55 - 75	975	CTX ³ 100	75
-	-	MPX ³ 100H	90	70 - 90	1170	CTX ³ 100	85
45	80	MPX ³ 100H	100	80 - 100	1300	CTX ³ 100	85

Definition type 2 coordination according to IEC 947-4-1:

- The contactor or the starter must not endanger persons or systems in the event of a short-circuit.
- The contactor or the starter must be suitable for further use.
- No damage to the overload relay or other parts may occur with the exception of welding of the contactor or starter contacts provided that these can be easily separated without significant deformation (such as with a screwdriver).

Accessory

Interlock unit, Cat.No 4168 80

The mechanical interlock unit provides 2NC contacts for use in electrical interlocking of two contactors

Wire kits

Used for making reversing circuit between two contactors

Contactor	Wire kit		Interlock unit	
	Cat.Nos	Weight	Cat.No	Weight
CTX ³ 22	4168 82	0.04 kg	4168 80	0.06 kg
CTX ³ 40	4168 83	0.05 kg		
CTX ³ 65	4168 84	0.12 kg		
CTX ³ 100	4168 85	0.33 kg		
CTX ³ 150	-	-		

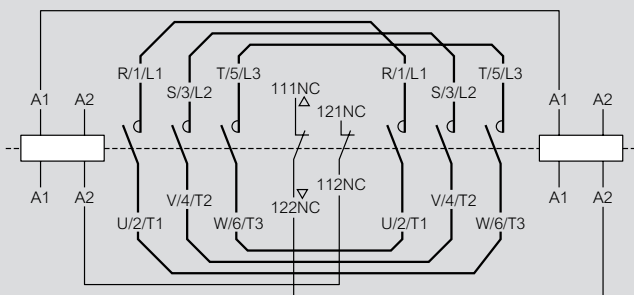

CTX³ 9 A - 150 A typical circuit diagram for reversing contactor

Rating of the contacts in the interlocks

Rated operation voltage (V)	600
Rated insulation voltage (V)	600
Rated frequency (Hz)	50/60
Rated thermal current (A)	10
Rated operation current (A) 240 V AC-15	3

Time delay blocks Cat.Nos 4168 70/71/72/73

Applying contactors	Cat.Nos	Rated voltage	Performance
CTX ³ 22 to CTX ³ 150	On delay	4168 70 AC/DC 24 to 48 V	<ul style="list-style-type: none"> • Mounting: Head on • Contact: 1 NC • Time delay: 1s to 30s On delay, Off delay
		4168 71 AC 110 to 230 V	
Off delay	4168 72 AC/DC 24 to 48 V	<ul style="list-style-type: none"> • Frequency: AC 50/60 hz • Operation: Min. voltage 85% Max. voltage 110% • Accuracy of setting time: ± 20 % 	
	4168 73 AC 110 to 230 V		

Features of capacitor unit (Pre-loading resistor)

- Damping resistor that can limit the inrush current up to $60 \times I_n$ by closing earlier than the main contacts of the contactor
- No heat loss by the serial resistor
- Eliminates the switching surge
- Improves the performance of the capacitor system

Operation sequence

Capacitor unit: OFF
Contactor: OFF

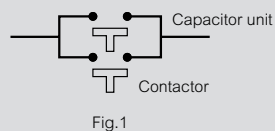

Fig.1

Capacitor unit: ON
Contactor: OFF

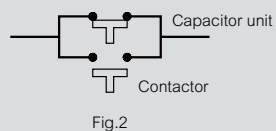

Fig.2

Capacitor unit: OFF
Contactor: ON

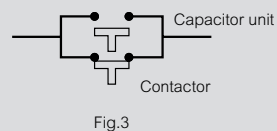

Fig.3

Note - Closing sequence: Fig.1 => Fig.2 => Fig.3
Opening sequence: Fig.3 => Fig.1

MPCBs MPX³

wiring capacity and accessories

Mounting

MPX³ 32: 35 mm rail (depth 15 mm)
 MPX³ 63: 35 mm rail (depth 15 mm) or screws
 MPX³ 100: 35 mm (depth 15 mm) or 75 mm rail or screws

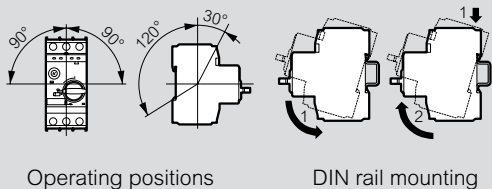

Caution for thermal adjustments

1. Keep the setting range as shown below
2. Moving counterclockwise out of the setting range may cause the damage of the device

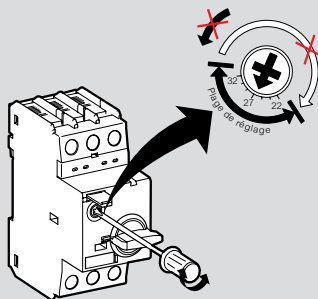

Dial setting method

3. Calibration by ambient air temperature

A: set to one point lower	Calibrated automatically	B: set to one point higher
-20 °C	-5 °C	+40 °C
+60 °C		

In case of using out of the standard air temperature range (-5 °C to +40 °C) it needs to be calibrated by one point

Environment

Ambient air temperature:
 - storage: -50...+ 80 °C
 - operation: -20...+ 60 °C
 Ambient temperature compensation: - 20...+ 60 °C
 Maximum operating altitude: 2000 m
 Protection degree: IP20
 Shock resistance: 25 g
 Vibration resistance: 5~150 Hz

Power consumption

	MPX ³ 32S	MPX ³ 32H/MA	MPX ³ 63H	MPX ³ 100H
Total power loss Pv	In = 0.16 to 1.6 A: 4.4	In = 0.16 to 1.6 A: 4.4	In = 10 to 22 A: 10.2	In = 17 to 32 A : 15
Circuit breaker at rated load operating temperature (W)	In = 2.5 to 26 A : 7.4 In = 32 A : 4.0	In = 2.5 to 26 A : 7.4 In = 32 A : 4.0	In = 26 to 63 A: 9.7	In = 40 to 63 A : 21.8 In = 75 to 100 A: 17.8

MPX³ 32S

Rated operational current I _e (A)	0.16	0.25	0.4	0.63	1	1.6	2.5	4	6	8	10	13	17	22	26	32
Switching of standard three-phase motors AC-2, AC-3																
230/240 V (kW)	-	0.03	0.06	0.09	0.12	0.18/0.25	0.37	0.55/0.75	1.1/1.5	1.5	2.2/3	3	3.7/4	4	5.5	7.5
400/415 V (kW)	0.02	0.06	0.09	0.12	0.18/0.25	0.37/0.55	0.75	1.1/1.5	2.2	3	3.7/4	5.5	7.5	7.5	11	15
500 V (kW)	-	-	-	0.25	0.37	0.55/0.75	1.1	1.5/2.2	3	3.7	4/5.5	7.5	11	11	15	18.5
690 V (kW)	-	-	-	0.25	0.37/0.55	0.75/1.1	1.5	2.2/3	3.7/4	5.5	7.5	11	11	15	18.5	22

MPX³ 32H

Rated operational current I _e (A)	0.16	0.25	0.4	0.63	1	1.6	2.5	4	6	8	10	13	17	22	26	32
Switching of standard three-phase motors AC-2, AC-3																
230/240 V (kW)	-	0.03	0.06	0.09	0.12	0.18/0.25	0.37	0.55/0.75	1.1/1.5	1.5	2.2/3	3	3.7/4	4	5.5	7.5
400/415 V (kW)	0.02	0.06	0.09	0.12	0.18/0.25	0.37/0.55	0.75	1.1/1.5	2.2	3	3.7/4	5.5	7.5	7.5	11	15
500 V (kW)	-	-	-	0.25	0.37	0.55/0.75	1.1	1.5/2.2	3	3.7	4/5.5	7.5	11	11	15	18.5
690 V (kW)	-	-	-	0.25	0.37/0.55	0.75/1.1	1.5	2.2/3	3.7/4	5.5	7.5	11	11	15	18.5	22

Industrial contactors CTX³

technical characteristics

Selection chart

- The Full Load Current (FLC) indicated for 3-phase motors are of 'squirrel-cage Induction motors' at full load.
- Contactors are of the minimum ratings. Higher rating of contactors can be used.
- Selection chart is for standard 3-phase, squirrel cage motor with average power factor and efficiency.
- Selection is valid only for complete Legrand products.
- Compliance to Type '2' co-ordination is not assured in case these groupings are changed to use another product.
- Normal motor starting time (<=5 Sec) is assumed.

Compact motor starter (MPCB + Contactors)

Coordination: Compact motor starters (MPCB + Contactors) Type 2

According to IEC 60947-4-1

Performance: U _e = 415 [V]		
MPX ³	S	H
MPX ³ 32	50 [kA]	50 [kA]
MPX ³ 63	-	50 [kA]
MPX ³ 100	-	50 [kA]



Motor		MPX ³		CTX ³
[kW]	[A]	Type	Rating In [A]	Type
0.37	1.1	MPX ³ 32S	1.6	CTX ³ 22 - 9 [A]
0.55	1.5	MPX ³ 32S	1.6	
0.75	1.9	MPX ³ 32S	2.5	CTX ³ 22 - 12 [A]
1.1	2.7	MPX ³ 32S	4	CTX ³ 22 - 18 [A]
1.5	3.6	MPX ³ 32S	4	
2.2	5.2	MPX ³ 32S	6	
3	6.8	MPX ³ 32S	8	
4	9	MPX ³ 32S	10	
5.5	11.5	MPX ³ 32H	13	CTX ³ 22 - 22 [A]
7.5	15.5	MPX ³ 32H	17	CTX ³ 40 - 32 [A]
10	20	MPX ³ 32H	22	
11	22	MPX ³ 32H	26	
15	29	MPX ³ 32H	32	CTX ³ 40 - 40 [A]
18.5	35	MPX ³ 63H	40	
22	41	MPX ³ 63H	50	CTX ³ 65 - 50 [A]
30	55	MPX ³ 63H	63	CTX ³ 65 - 65 [A]
37	67	MPX ³ 100H	75	CTX ³ 100 - 75 [A]
45	80	MPX ³ 100H	100	CTX ³ 100 - 85 [A]

Industrial contactors CTX³

technical characteristics

3P 9 A - 150 A with MPCB

Coordination: Type 2 (continued)

According to IEC 60947-4-1

Performance: U _e = 440 [V]		
MPX ³	S	H
MPX ³ 32	38 [kA]	50 [kA]
MPX ³ 63	-	35 [kA]
MPX ³ 100	-	50 [kA]

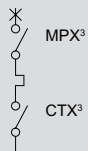

Motor		MPX ³		CTX ³
[kW]	[A]	Type	Rating I _n [A]	Type
0.37	0.99	MPX ³ 32S	1	CTX ³ 22 - 9 [A]
0.55	1.36	MPX ³ 32S	1.6	
0.75	1.68	MPX ³ 32S	2.5	
1.1	2.37	MPX ³ 32S	2.5	
1.5	3.06	MPX ³ 32S	4	CTX ³ 22 - 18 [A]
2.2	4.42	MPX ³ 32H	6	CTX ³ 22 - 22 [A]
3	5.57	MPX ³ 32H	6	
3.7	7.1	MPX ³ 32H	8	CTX ³ 40 - 32 [A]
4	7.9	MPX ³ 32H	8	
5.5	10.4	MPX ³ 32H	13	
9	16.9	MPX ³ 63H	17	CTX ³ 40 - 40 [A]
11	20.1	MPX ³ 63H	22	
15	26.5	MPX ³ 63H	32	
18.5	32.8	MPX ³ 63H	40	CTX ³ 65 - 50 [A]
22	39	MPX ³ 63H	40	
25	45.3	MPX ³ 63H	50	CTX ³ 65 - 65 [A]
30	51.5	MPX ³ 100H	63	
33	58	MPX ³ 100H	63	
37	64	MPX ³ 100H	63	CTX ³ 100 - 85 [A]
40	67	MPX ³ 100H	75	
45	76	MPX ³ 100H	75	

Industrial contactors CTX³

technical characteristics

Motor starters

Magnetic protection + Contactor + Thermal overload relay

Table-1: DX³ MCB U_e = 400 [V]

Motor		Circuit-breaker				Contactor	Thermal relay			Test
Rated power (kW)	Rated current (A)	Type	Rated current (A)	Magnetic threshold (A)	Reference	Type	Type	Setting range (A)	Reference	Rated conditional short-circuit current I _q (kA)
0.37	1.10	DX ³ MA	1.6	20	4098 76	CTX ³ 22 9 A	RTX ³ 40	1 - 1.6	4166 45/65	15
0.55	1.5	DX ³ MA	1.6	20	4098 76	CTX ³ 22 9 A	RTX ³ 40	1 - 1.6	4166 45/65	15
0.75	1.9	DX ³ MA	2.5	32	4098 77	CTX ³ 22 9 A	RTX ³ 40	1.6 - 2.5	4166 46/66	15
1.1	2.7	DX ³ MA	4	50	4098 78	CTX ³ 22 9 A	RTX ³ 40	2.5 - 4	4166 47/67	15
1.5	3.5	DX ³ MA	4	50	4098 78	CTX ³ 22 9 A	RTX ³ 40	2.5 - 4	4166 47/67	15
2.2	5	DX ³ MA	6.3	80	4098 79	CTX ³ 22 9 A	RTX ³ 40	4 - 6	4166 48/68	15
2.5	5.7	DX ³ MA	6.3	80	4098 79	CTX ³ 22 9 A	RTX ³ 40	4 - 6	4166 48/68	15
3	6.7	DX ³ MA	10	125	4098 80	CTX ³ 22 12 A	RTX ³ 40	5 - 8	4166 49/69	15
3.7	8	DX ³ MA	10	125	4098 80	CTX ³ 22 12 A	RTX ³ 40	6 - 9	4166 50/70	15
4	8.5	DX ³ MA	10	125	4098 80	CTX ³ 22 12 A	RTX ³ 40	7 - 10	4166 51/71	15
5.5	11	DX ³ MA	12.5	160	4098 81	CTX ³ 22 22 A	RTX ³ 40	9 - 13	4166 52/72	15
6.3	13	DX ³ MA	16	200	4098 82	CTX ³ 22 22 A	RTX ³ 40	12 - 18	4166 53/73	15
7.5	15	DX ³ MA	16	200	4098 82	CTX ³ 22 22 A	RTX ³ 40	12 - 18	4166 53/73	15
10	20	DX ³ MA	25	320	4098 83	CTX ³ 22 22 A	RTX ³ 40	16 - 22	4166 54/74	15
11	22	DX ³ MA	25	320	4098 83	CTX ³ 22 22 A	RTX ³ 40	18 - 25	4166 55/75	15
12.5	25	DX ³ MA	25	320	4098 83	CTX ³ 40 32 A	RTX ³ 40	22 - 32	4166 56/76	15
15	29	DX ³ MA	40	500	4098 84	CTX ³ 40 32 A	RTX ³ 40	22 - 32	4166 56/76	10
16	31	DX ³ MA	40	500	4098 84	CTX ³ 40 32 A	RTX ³ 40	22 - 32	4166 56/76	10
18.5	35	DX ³ MA	40	500	4098 84	CTX ³ 40 40 A	RTX ³ 40	28 - 40	4166 57/77	10
20	38	DX ³ MA	40	500	4098 84	CTX ³ 40 40 A	RTX ³ 40	28 - 40	4166 57/77	10
22	41	DX ³ MA	63	880	4098 85	CTX ³ 65 50 A	RTX ³ 65	34 - 50	4166 89 4167 09	10
25	47	DX ³ MA	63	880	4098 85	CTX ³ 65 50 A	RTX ³ 65	34 - 50	4166 89 4167 09	10
30	57	DX ³ MA	63	880	4098 85	CTX ³ 65 65 A	RTX ³ 65	45 - 65	4166 90 4167 10	10
31.5	59	DX ³ MA	63	880	4098 85	CTX ³ 65 65 A	RTX ³ 65	45 - 65	4166 90 4167 10	10

Table-2: DPX³ MCCB : U_e = 400 [V]

Coordination: Type 2 (continued)

According to IEC 60947-4-1

Motor		Circuit-breaker				Contactor	Thermal relay			Test
Rated power (kW)	Rated current (A)	Type	Rated current (A)	Magnetic threshold (A)	Reference	Type	Type	Setting range (A)	Reference	Conditional short-circuit current I _q (kA)
15	29	DPX ³ 160	40	140 - 400	4201 22	CTX ³ 65 50 A	RTX ³ 65	24 - 36	4166 87 4167 07	50
16	31	DPX ³ 160	40	140 - 400	4201 22	CTX ³ 65 50 A	RTX ³ 65	24 - 36	4166 87 4167 07	50
18.5	35	DPX ³ 160	40	140 - 400	4201 22	CTX ³ 65 50 A	RTX ³ 65	28 - 40	4166 88 4167 08	50
20	38	DPX ³ 160	40	140 - 400	4201 22	CTX ³ 65 50 A	RTX ³ 65	34 - 50	4166 89 4167 09	50
22	41	DPX ³ 160	63	220 - 630	4201 23	CTX ³ 65 65 A	RTX ³ 65	34 - 50	4166 89 4167 09	50
25	47	DPX ³ 160	63	220 - 630	4201 23	CTX ³ 100 85 A	RTX ³ 100	34 - 50	4167 26/46	50
30	57	DPX ³ 160	63	220 - 630	4201 23	CTX ³ 100 100 A	RTX ³ 100	45 - 65	4167 27/47	50
31.5	59	DPX ³ 160	63	220 - 630	4201 23	CTX ³ 100 100 A	RTX ³ 100	54 - 75	4167 28/48	50
37	68	DPX ³ 250	100	350 - 1000	4206 05	CTX ³ 100 100 A	RTX ³ 100	63 - 85	4167 29/49	50
40	74	DPX ³ 250	100	350 - 1000	4206 05	CTX ³ 150 130 A	RTX ³ 150	63 - 85	4167 62/72	50
45	82	DPX ³ 250	100	350 - 1000	4206 05	CTX ³ 150 130 A	RTX ³ 150	63 - 85	4167 62/72	50
50	92	DPX ³ 250	100	350 - 1000	4206 05	CTX ³ 150 130 A	RTX ³ 150	80 - 105	4167 63/73	50
55	102	DPX ³ 250	100	350 - 1000	4206 05	CTX ³ 150 150 A	RTX ³ 150	95 - 130	4167 64/74	50
63	115	DPX ³ 250	160	560 - 1000	4206 07	CTX ³ 150 150 A	RTX ³ 150	95 - 130	4167 64/74	50

Industrial contactors CTX³

technical characteristics

Table-3: DPX³ MCCB : Ue = 440 [V]

Coordination: Type 2 (continued)
According to IEC 60947-4-1

Motor		Circuit-breaker				Contactor	Thermal relay			Test
Rated power (kW)	Rated current (A)	Type	Rated current (A)	Magnetic threshold (A)	Reference	Type	Type	Setting range (A)	Reference	Conditional short-circuit current I _q (kA)
15	27	DPX ³ 160	40	140 - 400	4201 22	CTX ³ 65 50 A	RTX ³ 65	24 - 36	4166 87 4167 07	30
16	29	DPX ³ 160	40	140 - 400	4201 22	CTX ³ 65 50 A	RTX ³ 65	24 - 36	4166 87 4167 07	30
18.5	34	DPX ³ 160	40	140 - 400	4201 22	CTX ³ 65 65 A	RTX ³ 65	28 - 40	4166 88 4167 08	30
20	37	DPX ³ 160	40	140 - 400	4201 22	CTX ³ 65 65 A	RTX ³ 65	28 - 40	4166 88 4167 08	30
22	40	DPX ³ 160	40	140 - 400	4201 23	CTX ³ 100 75 A	RTX ³ 100	34 - 50	4167 26/46	30
25	45	DPX ³ 160	63	220 - 630	4201 23	CTX ³ 100 85 A	RTX ³ 100	34 - 50	4167 26/46	30
30	53	DPX ³ 160	63	220 - 630	4201 23	CTX ³ 100 100 A	RTX ³ 100	45 - 65	4167 27/47	30
31.5	56	DPX ³ 160	63	220 - 630	4201 23	CTX ³ 100 100 A	RTX ³ 100	45 - 65	4167 27/47	30
37	65	DPX ³ 250	100	350 - 1000	4206 05	CTX ³ 100 100 A	RTX ³ 100	54 - 75	4167 28/48	50
40	71	DPX ³ 250	100	350 - 1000	4206 05	CTX ³ 150 130 A	RTX ³ 150	63 - 85	4167 62/72	50
45	78	DPX ³ 250	100	350 - 1000	4206 05	CTX ³ 150 130 A	RTX ³ 150	63 - 85	4167 62/72	50
50	88	DPX ³ 250	100	350 - 1000	4206 05	CTX ³ 150 130 A	RTX ³ 150	80 - 105	4167 63/73	50
55	98	DPX ³ 250	100	350 - 1000	4206 05	CTX ³ 150 150 A	RTX ³ 150	80 - 105	4167 63/73	50
63	110	DPX ³ 250	160	560 - 1000	4206 07	CTX ³ 150 150 A	RTX ³ 150	95 - 130	4167 64/74	50

Table-4: DPX³ MCCBs : Ue = 400 [V]

Coordination: Type 2 (continued)
According to IEC 60947-4-1

Motor		Circuit-breaker				Contactor	Thermal relay			Test
Rated power (kW)	Rated current (A)	Type	Rated current (A)	Magnetic threshold (A)	Reference	Type	Type	Setting range (A)	Reference	Conditional short-circuit current I _q (kA)
75	137	DPX ³ 250	160	560 - 1600	4206 07	CTX ³ 225 185 A	RTX ³ 225	100 - 160	4167 82	50
90	164	DPX ³ 250	250	900 - 2500	4206 09	CTX ³ 225 185 A	RTX ³ 225	120 - 185	4167 83	50
110	204	DPX ³ 250	250	900 - 2500	4206 09	CTX ³ 225 225 A	RTX ³ 225	160 - 240	4167 84	50
132	238	DPX ³ 250	250	900 - 2500	4206 09	CTX ³ 400 265 A	RTX ³ 400	200 - 330	4167 90	50
150	262	DPX ³ 630	320	1600 - 3200	4220 29	CTX ³ 400 330 A	RTX ³ 400	200 - 330	4167 90	50
160	282	DPX ³ 630	320	1600 - 3200	4220 29	CTX ³ 400 330 A	RTX ³ 400	260 - 400	4167 91	50
200	350	DPX ³ 630	400	2000 - 3200	4220 30	CTX ³ 400 400 A	RTX ³ 400	260 - 400	4167 91	50
220	387	DPX ³ 630	400	1600 - 3200	4220 30	CTX ³ 400 400 A	RTX ³ 400	260 - 400	4167 91	50
250	440	DPX ³ 630	500	1600 - 3200	4220 31	CTX ³ 800 630 A	RTX ³ 800	400 - 630	4167 94	50

Table-5: DPX³ MCCB : Ue = 440 [V]

Motor		Circuit-breaker				Contactor	Thermal relay			Test
Rated power (kW)	Rated current (A)	Type	Rated current (A)	Magnetic threshold (A)	Reference	Type	Type	Setting range (A)	Reference	Conditional short-circuit current I _q (kA)
75	129	DPX ³ 250	160	560 - 1600	4206 07	CTX ³ 225 185 A	RTX ³ 225	100 - 160	4167 82	50
90	157	DPX ³ 250	160	560 - 1600	4206 07	CTX ³ 225 225 A	RTX ³ 225	120 - 185	4167 83	50
110	188	DPX ³ 250	250	900 - 2500	4206 09	CTX ³ 400 265 A	RTX ³ 400	160 - 240	4167 89	50
132	218	DPX ³ 250	250	900 - 2500	4206 09	CTX ³ 400 265 A	RTX ³ 400	160 - 240	4167 89	50
150	244	DPX ³ 630	320	1600 - 3200	4220 29	CTX ³ 400 400 A	RTX ³ 400	200 - 330	4167 90	50
160	260	DPX ³ 630	320	1600 - 3200	4220 29	CTX ³ 400 400 A	RTX ³ 400	200 - 330	4167 90	50
200	330	DPX ³ 630	400	1600 - 3200	4220 30	CTX ³ 800 630 A	RTX ³ 800	260 - 400	4167 93	50
220	355	DPX ³ 630	400	1600 - 3200	4220 30	CTX ³ 800 630 A	RTX ³ 800	260 - 400	4167 93	50
250	405	DPX ³ 630	500	1600 - 3200	4220 31	CTX ³ 800 800 A	RTX ³ 800	400 - 600	4167 94	50

Industrial contactors CTX³

technical characteristics

Table-6: DX³ MCB : U_e = 400 [V]

Coordination: Type 2 (continued)
According to IEC 60947-4-1

Motor		Circuit-breaker				Contactor	Test
Rated power (kW)	Rated current (A)	Type	Rated current (A)	Magnetic threshold (A)	Reference	Type	Rated conditional short-circuit current I _q (kA)
5.5	11	DX ³ MA	12.5	160	4098 91	4164 26	15
6.3	13	DX ³ MA	16	200	4098 92	4164 26	15
7.5	15	DX ³ MA	16	200	4098 92	4164 26	15
10	20	DX ³ MA	25	320	4098 93	4164 26	15
11	22	DX ³ MA	25	320	4098 93	4164 26	15
18.5	35	DX ³ MA	40	500	4098 94	4164 36	10
20	38	DX ³ MA	40	500	4098 94	4164 36	10
30	57	DX ³ MA	63	880	4098 95	4164 46	10
31.5	59	DX ³ MA	63	880	4098 95	4164 46	10

Table-7: DPX³ MCCB : U_e = 400 [V]

Motor		Circuit-breaker				Contactor	Test
Rated power (kW)	Rated current (A)	Type	Rated current (A)	Magnetic threshold (A)	Reference	Type	conditional short-circuit current I _q (kA)
5.5	11.5	DPX ³ 160	16	160	4200 90	4164 36	36
7.5	15.5	DPX ³ 160	16	160	4200 90	4164 36	36
15	29	DPX ³ 160	40	400	4200 92	4164 56	36
16	31	DPX ³ 160	40	400	4200 92	4164 56	36
18.5	35	DPX ³ 160	40	400	4200 92	4164 56	36
20	38	DPX ³ 160	40	400	4200 92	4164 56	36
37	68	DPX ³ 160	100	1000	4200 95	4164 66	36
40	74	DPX ³ 160	100	1000	4200 95	4164 66	36
45	82	DPX ³ 160	100	1000	4200 95	4164 66	36
50	92	DPX ³ 160	100	1000	4200 95	4164 66	36
55	102	DPX ³ 160	125	1250	4200 96	4164 76	36
63	115	DPX ³ 160	125	1250	4200 96	4164 76	36

Table-8: DPX³ MCCB : U_e = 400 [V]

Coordination: Type 2 (continued)
According to IEC 60947-4-1

Motor		Circuit-breaker				Contactor	Test
Rated power (kW)	Rated current (A)	Type	Rated current (A)	Magnetic threshold (A)	Reference	Type	Conditional short-circuit current I _q (kA)
22	41	DPX ³ 160	63	220 - 630	4201 33	4164 46	50
25	47	DPX ³ 160	63	220 - 630	4201 33	4164 56	50
40	74	DPX ³ 250	100	350 - 1000	4206 15	4164 66	50
45	82	DPX ³ 250	100	350 - 1000	4206 15	4164 66	50
50	92	DPX ³ 250	100	350 - 1000	4206 15	4164 66	50
55	102	DPX ³ 250	100	350 - 1000	4206 15	4164 76	50
63	115	DPX ³ 250	160	560 - 1600	4206 17	4164 76	50
110	204	DPX ³ 250	250	900 - 2500	4206 19	4164 86	50
150	262	DPX ³ 630	320	1600 - 3200	4220 34	4164 96	50
160	282	DPX ³ 630	320	1600 - 3200	4220 34	4164 96	50
200	350	DPX ³ 630	400	2000 - 3200	4220 35	4165 06	50
220	387	DPX ³ 630	400	1600 - 3200	4220 35	4165 06	50
250	440	DPX ³ 630	500	1600 - 3200	4220 36	4165 16	50

Industrial contactors CTX³

technical characteristics

Table-9: DPX³ MCCB : Ue = 440 [V]

Coordination: Type 2 (continued)

According to IEC 60947-4-1

Motor		Circuit-breaker				Contactor	Test
Rated power (kW)	Rated current (A)	Type	Rated current (A)	Magnetic threshold (A)	Reference	Type	Conditional short-circuit current Iq (kA)
18.5	34	DPX ³ 160	40	140 - 400	4201 32	4164 46	30
20	37	DPX ³ 160	40	140 - 400	4201 32	4164 46	30
25	45	DPX ³ 160	63	220 - 630	4201 33	4164 56	30
40	71	DPX ³ 250	100	350 - 1000	4206 15	4164 66	50
45	78	DPX ³ 250	100	350 - 1000	4206 15	4164 66	50
50	88	DPX ³ 250	100	350 - 1000	4206 15	4164 66	50
55	98	DPX ³ 250	100	350 - 1000	4206 15	4164 76	50
63	110	DPX ³ 250	160	560 - 1600	4206 17	4164 76	50
90	157	DPX ³ 250	160	560 - 1600	4206 17	4164 86	50
150	244	DPX ³ 630	320	1600 - 3200	4220 34	4165 06	50
160	260	DPX ³ 630	320	1600 - 3200	4220 34	4165 06	50
200	330	DPX ³ 630	400	1600 - 3200	4220 35	4165 16	50
220	355	DPX ³ 630	400	1600 - 3200	4220 35	4165 16	50
250	405	DPX ³ 630	500	1600 - 3200	4220 36	4165 26	50

Selection table for CTX³ contactors for capacitor banks

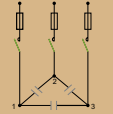
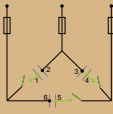
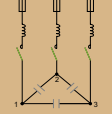
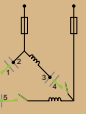
Step power at 400 V up to	Terminals	Steps without detuned reactors				Steps with detuned reactors	
		With 3 terminals capacitors Alpivar ³ & Alpican		With 6 terminals Alpivar ³ (wiring inside)		With 3 terminals capacitors Alpivar ³ & Alpican	With 6 terminals Alpivar ³ (wiring inside)
							
		Contactors	+ capacitor switching units CTX-C	Contactors	+ capacitor switching units CTX-C	Contactors	Contactors
7.5 kVAr	Screw terminals	4160 8X	4168 74	4160 8X	4168 74	4160 9X	4160 8X
12.5 kVAr	Screw terminals	4160 9X	4168 74	4160 9X	4168 74	4161 0X	4160 9X
20 kVAr	Screw terminals	4161 2X	4168 74	4161 1X	4168 74	4161 2X	4161 0X
25 kVAr	Screw terminals	4161 2X	4168 74	4161 1X	4168 74	4161 3X	4161 0X
30 kVAr	Screw terminals	4161 3X	4168 74	4161 2X	4168 74	4161 4X	4161 1X
40 kVAr	Screw terminals	4161 4X	4168 75	4161 3X	4168 74	4161 6X	4161 3X
	Cage terminals	4161 5X	4168 76	4161 5X	4168 76	4161 7X	4161 5X
50 kVAr	Screw terminals	4161 8X	4168 77	4161 4X	4168 75	4161 8X	4161 3X
	Cage terminals	4161 9X	4168 76	4161 5X	4168 76	4161 9X	4161 5X
60 kVAr	Screw terminals	4162 2X	4168 77	4161 8X	4168 77	4162 0X	4161 6X
	Cage terminals	4162 3X	4168 76	4161 9X	4168 76	4162 1X	4161 7X
75 kVAr	Screw terminals	NA		4161 8X	4168 77	4162 4Y	4161 6X
	Cage terminals	NA		4161 9X	4168 76	4162 5Y	4161 7X
80 kVAr	Screw terminals	NA		4162 2X	4168 77	4162 6Y	4162 4Y
	Cage terminals	NA		4162 3X	4168 76	4162 7Y	4162 5Y

Coil voltage	X	Coil voltage	Y
24 V AC	0	24 V AC	0
24 V DC	1	24 V DC	1
48 V AC	2	48 V AC	2
48 V DC	3	48 V DC	3
110 V AC	4	100-240 V AC / 100-220 V DC	6
230 V AC	6		
380 V AC	8		9
415 V AC	9	400-440 V AC	

Industrial contactors CTX³

technical characteristics

Size of wire and tightening torque:

3P 9 A - 150 A

Frame	Wire type	Main Terminal Size								Torque		
			(AWG / mm ²)							mm(max)	{lb-in}	{Nm}
CTX ³ 22 - 9 A		M4	18-10 / 1-6		18-10 / 1-6		18-10 / 1-6		9.6	20	2.25	23
CTX ³ 22 - 12 A			18-10 / 1-6		16-10 / 1-6		16-10 / 1-6					
CTX ³ 22 - 18 A			18-10 / 1-6		16-8 / 1.5-10		16-8 / 1.5-10					
CTX ³ 22 - 32 A			18-10 / 1-6		14-8 / 2.5-10		14-8 / 2.5-10					
CTX ³ 40 - 22 A		M5	18-10 / 1-6		8-6 / 10-16		8-6 / 10-16		12.8	20	2.25	23
CTX ³ 40 - 40 A			18-10 / 1-6		8-6 / 10-16		8-6 / 10-16			35	4	41
CTX ³ 65 - 50 A		M6	-		10-4 / 6-25		10-4 / 6-25		14	35	4	41
CTX ³ 65 - 65 A			-		8-3 / 10-35		8-3 / 10-35					
CTX ³ 100 - 75 A		M8	-		8-2 / 10-35		8-2 / 10-35		17	45	5.1	52
CTX ³ 100 - 85 A			-		8-1/0 / 10-50		8-1/0 / 10-50					
CTX ³ 100 - 100 A			-		8-2/0 / 10-70		8-2/0 / 10-70					
CTX ³ 150 - 130 A		M8	-		3-2/0 / 35-70		3-2/0 / 35-70		24.5	80	9.1	93
CTX ³ 150 - 150 A			-		3-4/0 / 35-95		3-4/0 / 35-95					
CTX ³ 22 - 150 Aux/Coil		M4	20-14 / 0.5-2.5		18-12 / 0.75-2.5		18-12 / 0.75-2.5		7.6	15	1.75	18

Frame	Wire type								Torque	
		(AWG / mm ²)							mm(max)	{lb-in}
CTX ³ 65		0.75-35 / 18-2	0.75-25 / 18-4	0.75-35 / 18-2	0.75-25 / 18-4	0.75-25 / 18-4	0.75-16 / 18-6	---	35	4
CTX ³ 100		2.5-70 / 12-2	2.5-50 / 12-1	2.5-70 / 12-2	2.5-50 / 12-1	2.5-50 / 12-2	2.5-35 / 10-2	---	45	5.1
CTX ³ 150		2.5-70 / 12-2	2.5-50 / 12-1	35-95 / 3-4	35-95 / 3-4	35-95 / 3-4	35-95 / 3-4	---	80	9.1

3P 185 A - 800 A

Frame	Wire type	Main Terminal Size								Torque		
			(AWG / mm ²)							mm(max)	{lb-in}	{Nm}
CTX ³ 225 - 185 A		M10	-		1-4/0 / 50-95		1-4/0 / 50-95		25	130	14.7	150
CTX ³ 225 - 225 A			-		1/0-300 / 50-150		1/0-300 / 50-150					
CTX ³ 400 - 265 A		M12	-		3/0-500 / 95-240		3/0-500 / 95-240		30	200	22.6	230
CTX ³ 400 - 330 A			-		4/0-500 / 95-240		4/0-500 / 95-240					
CTX ³ 400 - 400 A			-		350-700 / 185-185 x 2		350-700 / 185-185 x 2					
CTX ³ 800 - 500 A		M16	-		350-800 / 185-240 x 2		350-800 / 185-240 x 2		40	500	26.5	270
CTX ³ 800 - 630 A			-		600-2000		-					
CTX ³ 800 - 800 A			-		1700-Busbar		-					
CTX ³ 225 - 800 Aux/Coil		M4	16-10 / 1.25-5.5		16-10 / 1.25-5.5		16-10 / 1.25-5.5		7.6	15	1.75	18

4P 40 A to 900 A

Frame size	Terminal screw		Size of wire [mm ²]	Connecting torque [kgf cm]
	Contactor			Contactor
4164 26	M4	9.6	2.5~10	15~22.5
4164 36	M5	12.8	10~16	26~39
4164 46	M6	14	16~35	45~67.5
4164 56	M8	17	25~50	100~150
4164 66	M8	17	35~70	100~150
4164 76	M8	17	35~95	100~150
4164 86	M10	25	50~150	150~225
4164 96, 4165 06	M12	30	95~240	250~375
4165 16, 4165 26	M16	40	185~480	600~1200

MPCBs MPX³

wiring capacity and accessories (continued)

MPX³ 32MA

Rated operational current I _e (A)		0.16	0.25	0.4	0.63	1	1.6	2.5	4	6	8	10	13	17	22	26	32
AC-2, AC-3																	
230/240 V	(kW)	-	0.03	0.06	0.09	0.12	0.18/0.25	0.37	0.55/0.75	1.1/1.5	1.5	2.2/3	3	3.7/4	4	5.5	7.5
400/415 V	(kW)	0.02	0.06	0.09	0.12	0.18/0.25	0.37/0.55	0.75	1.1/1.5	2.2	3	3.7/4	5.5	7.5	7.5	11	15
500 V	(kW)	-	-	-	0.25	0.37	0.55/0.75	1.1	1.5/2.2	3	3.7	4/5.5	7.5	11	11	15	18.5
690 V	(kW)	-	-	-	0.25	0.37/0.55	0.75/1.1	1.5	2.2/3	3.7/4	5.5	7.5	11	11	15	18.5	22

MPX³ 63H

Rated operational current I _e (A)		10	13	17	22	26	32	40	50	63
Switching of standard three-phase motors AC-2, AC-3										
230/240 V	(kW)	2.2/3	3	3.7/4	4	5.5	7.5	7.5	11	15
400/415 V	(kW)	3.7/4	5.5	7.5	7.5	11	15	18.5	22	30
500 V	(kW)	4/5.5	7.5	11	11	15	18.5	22	30	37
690 V	(kW)	7.5	11	11	15	18.5	22	30	45	55





MPX³ 100H

Rated operational current I _e (A)		17	22	26	32	40	50	63	75	90	100
Switching of standard three-phase motors AC-2, AC-3											
230/240 V	(kW)	3.7/4	4	5.5	7.5	7.5	11	15	22	30	30
400/415 V	(kW)	7.5	7.5	11	15	18.5	22	30	37	45	45
500 V	(kW)	11	11	15	18.5	22	30	37	45	55	63
690 V	(kW)	11	15	18.5	22	30	45	55	63	75	90

MPCBs MPX³

technical characteristics

Terminals

			MPX ³ 32S	MPX ³ 32H / 32 MA	MPX ³ 63H	MPX ³ 100H	
Conformity to standards			IEC60947 UL508, UL508 Type E				
Approvals			CE, UL				
Terminal type							
Single-core	1 conductor	(mm ²) / (AWG)	1...10 / 18...8	1...10 / 18...8	0.75...35 / 18...2	2.5...70 / 12...2/0	
	2 conductor	(mm ²) / (AWG)	1...6 / 18...10	1...6 / 18...10	0.75...25 / 18...4	2.5...50 / 12...1/0	
Stranded	1 conductor	(mm ²) / (AWG)	1...6 / 18...10	1...6 / 18...10	0.75...35 / 18...2	2.5...70 / 12...2/0	
	2 conductor	(mm ²) / (AWG)	1...6 / 18...10	1...6 / 18...10	0.75...25 / 18...4	2.5...50 / 12...1/0	
Flexible	1 conductor	(mm ²) / (AWG)	1...6 / 18...10	1...6 / 18...10	0.75...25 / 18...4	2.5...50 / 12...1/0	
	2 conductor	(mm ²) / (AWG)	0.75...4 / 18...10	0.75...4 / 18...10	0.75...16 / 18...6	2.5...35 / 10...2	
Tightening torque			(Nm) / (lb-in)	0.8...2.5 / 7...22	0.8...2.5 / 7...22	3...4.5 / 26...39	4...6 / 35...53

Auxiliaries

			Auxiliary contacts for front mounting		Auxiliary contacts for left side mounting		Alarm switch for left side mounting	
Rated thermal current / th	at 40 °C ambient temperature		(A)		10		10	
	at 60 °C ambient temperature		(A)		6		6	
Contact class coordination according to NEMA (UL/CSA-Standards)	AC		A600		A600		A600	
	DC		Q300		Q300		Q300	
Back-up fuses gG, gL			(A)		16		16	
Rated supply current	AC-15	(V)	-	240	24	240	24	240
		(A)	-	3	6	4	6	4
	DC-13	(V)	24	220	24	220	24	220
		(A)	1	0.1	2	0.25	2	0.25
Weight (g)			18		30		40	
Terminal type								
Screwdriver			Pozidriv size 2					
Single-core	1 conductor	(mm ²) / (AWG)	0.5...2.5 / 20...14		0.5...2.5 / 20...14		0.5...2.5 / 20...14	
	2 conductor	(mm ²) / (AWG)	-		0.5...2.5 / 20...14		0.5...2.5 / 20...14	
Stranded	1 conductor	(mm ²) / (AWG)	0.5...4 / 20...10		0.5...4 / 20...10		0.5...4 / 20...10	
	2 conductor	(mm ²) / (AWG)	0.75...2.5 / 18...14		0.75...2.5 / 18...14		0.75...2.5 / 18...14	
Tightening torque			(Nm) / (lb-in)		0.8...1.2 / 7...10		0.8...1.2 / 7...10	

			Undervoltage release for right side mounting	Undervoltage release with 2 auxiliary contacts for right side mounting	Shunt release for right side mounting	
Actuating voltage	Pull-in		0.7...1.1 x Us	0.85...1.1 x Us	0.85...1.1 x Us	
	Drop-out			0.7...0.35 x Us	0.7...0.35 x Us	
Rated control voltage	min:		24 V 50 Hz / 28 V 60 Hz	24 V 50 Hz / 28 V 60 Hz	24 V 50 Hz / 28 V 60 Hz	
	max:		415-440 V 50 Hz / 460-480 V 60 Hz	415-440 V 50 Hz / 460-480 V 60 Hz	415-440 V 50 Hz / 460-480 V 60 Hz	
Coil rating	Pull-in		8.5 VA, 6 W	8.5 VA, 6 W	8.5 VA, 6 W	
	Hold		3 VA, 12 W	3 VA, 12 W	3 VA, 12 W	
Opening time (ms)			-	20	20	
Weight (g)			18	30	40	
Terminal type						
Screwdriver			Pozidriv size 2			
Single-core	1 conductor	(mm ²) / (AWG)	0.5...2.5 / 20...14			
	2 conductor	(mm ²) / (AWG)	0.5...2.5 / 20...14			
Standard	1 conductor	(mm ²) / (AWG)	0.5...4 / 20...10			
	2 conductor	(mm ²) / (AWG)	0.75...2.5 / 18...14			
Tightening torque			(Nm) / (lb-in)			0.8...1.2 / 7...10

Thermal relays RTX³

tripping curves

RTX³ 40 - class 10 A

Cold starting

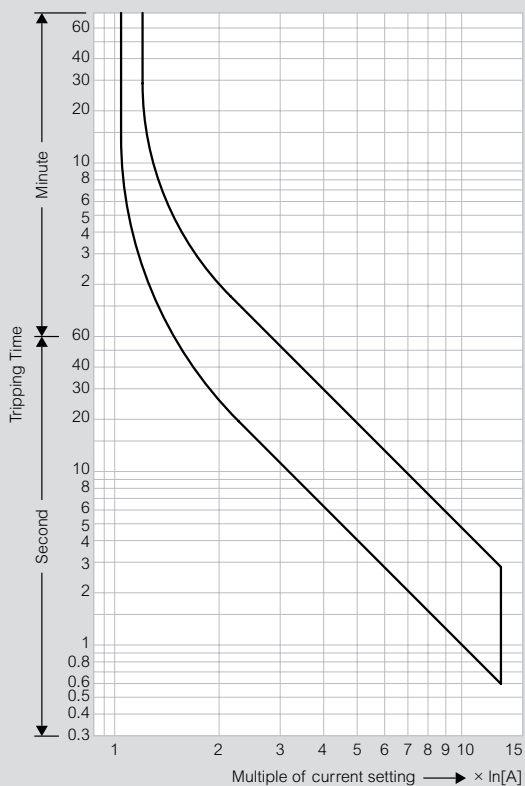

Hot starting

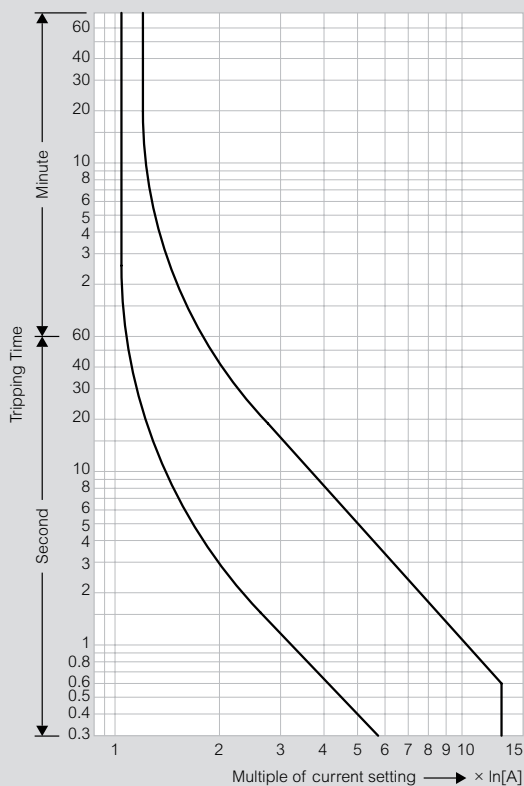

RTX³ 65 - class 10 A

Cold starting

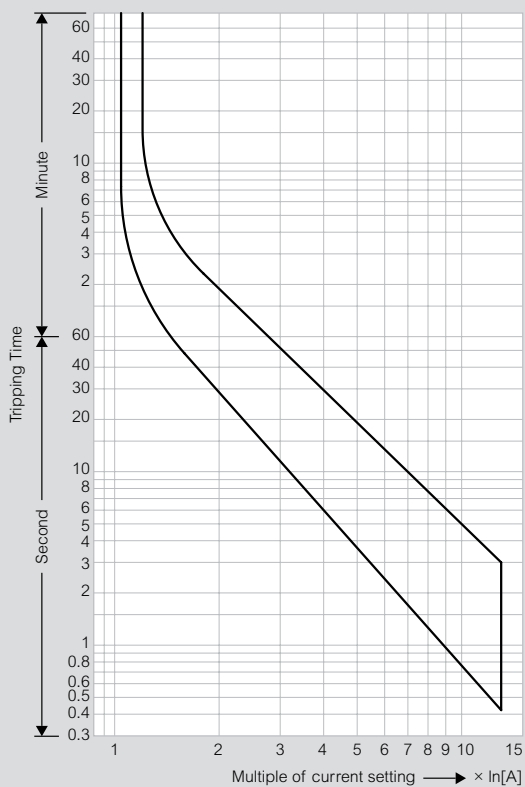

Hot starting

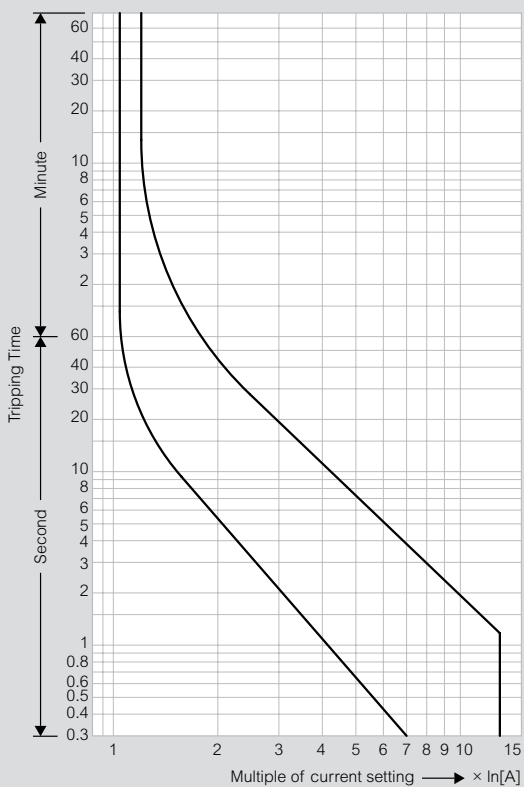

Thermal relays RTX³

tripping curves (continued)

RTX³ 100 - class 10 A

Cold starting

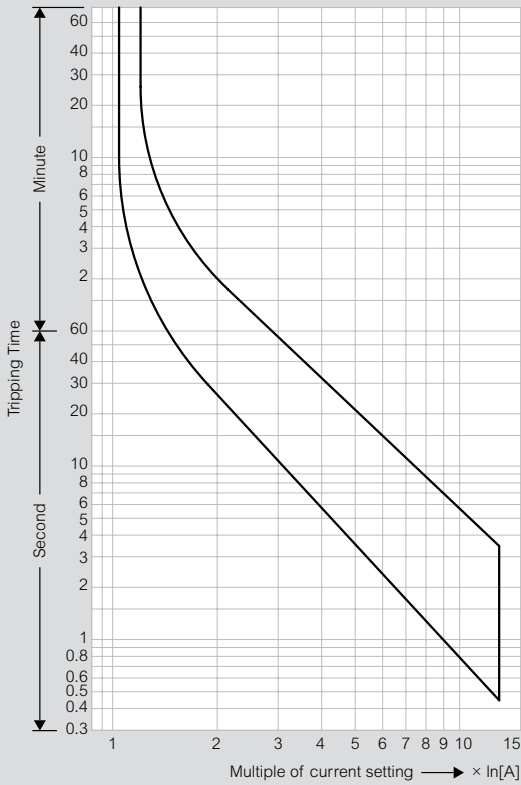

Hot starting

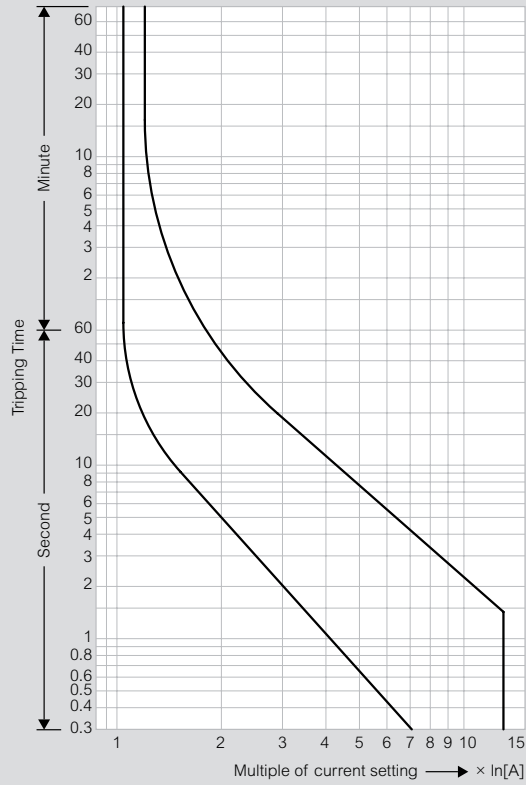

RTX³ 150 - class 10 A

Cold starting

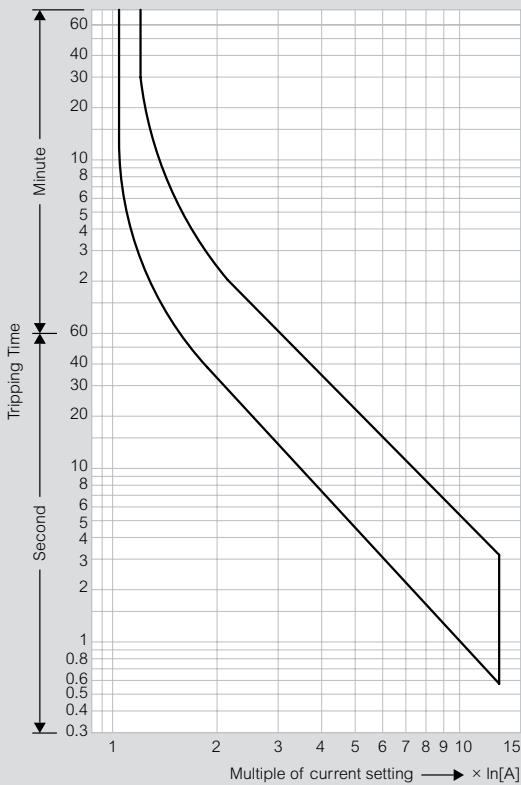

Hot starting

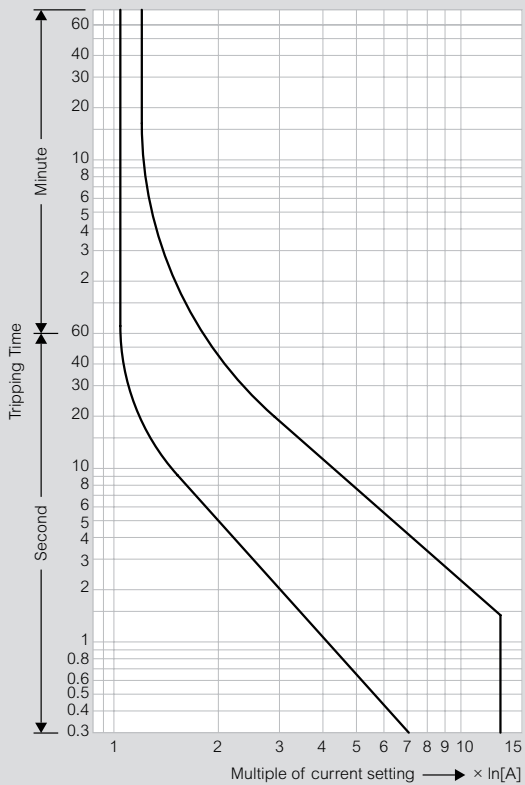

Thermal relays RTX³

tripping curves (continued)

RTX³ 225 - class 10 A

Cold starting

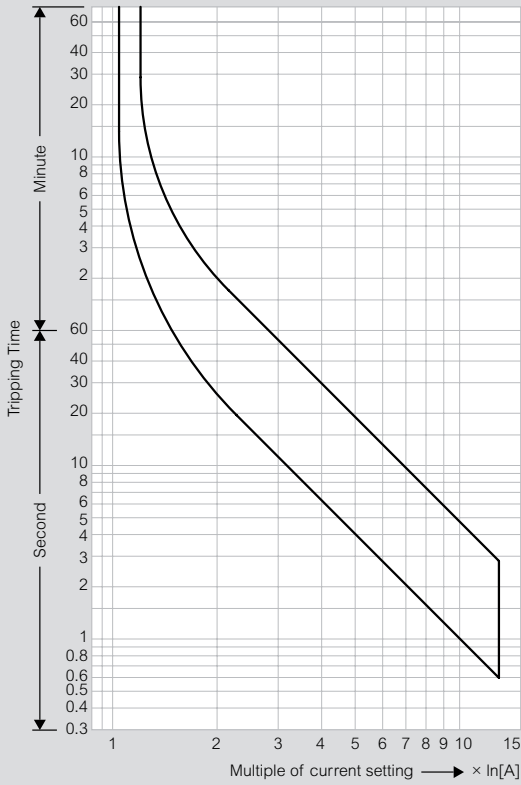

Hot starting

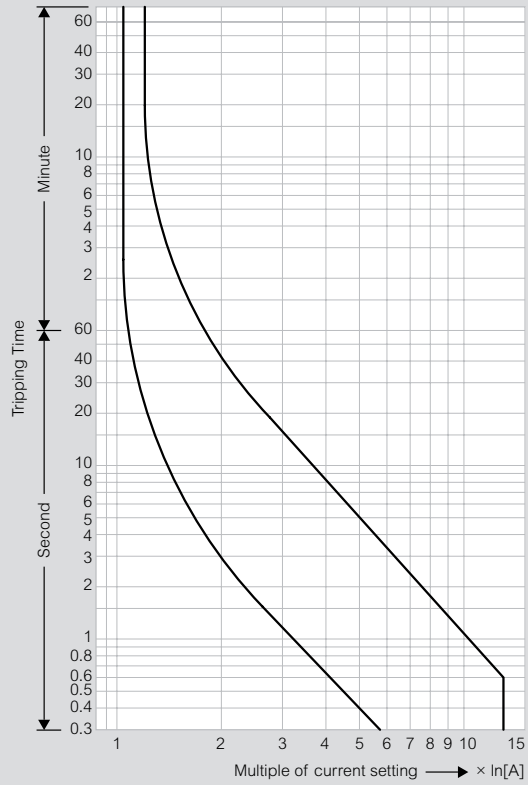

RTX³ 400 - class 10 A

Cold starting

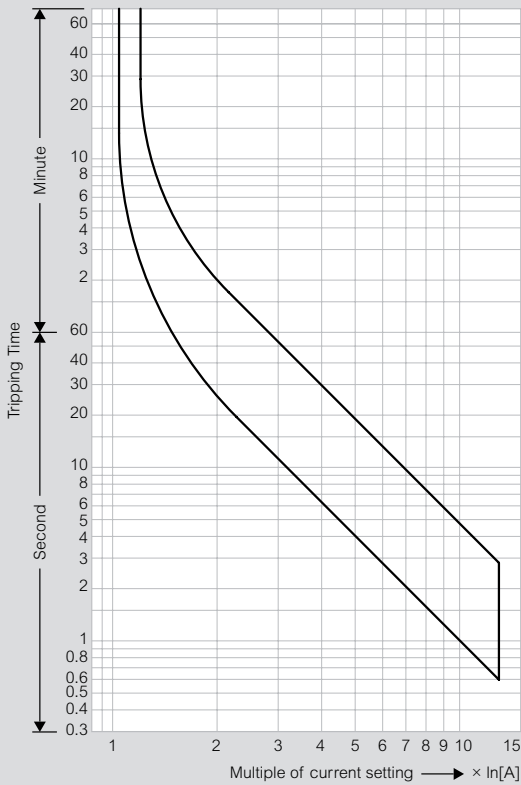

Hot starting

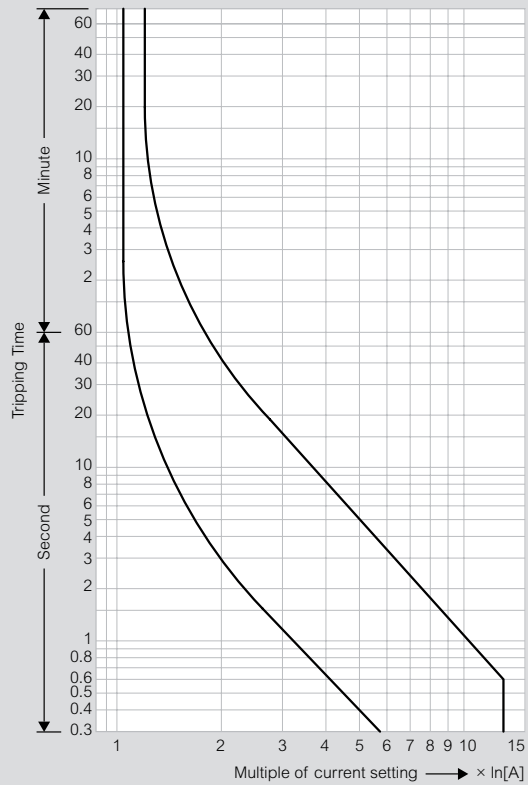

Thermal relays RTX³

tripping curves (continued)

RTX³ 800 - class 10 A

Cold starting

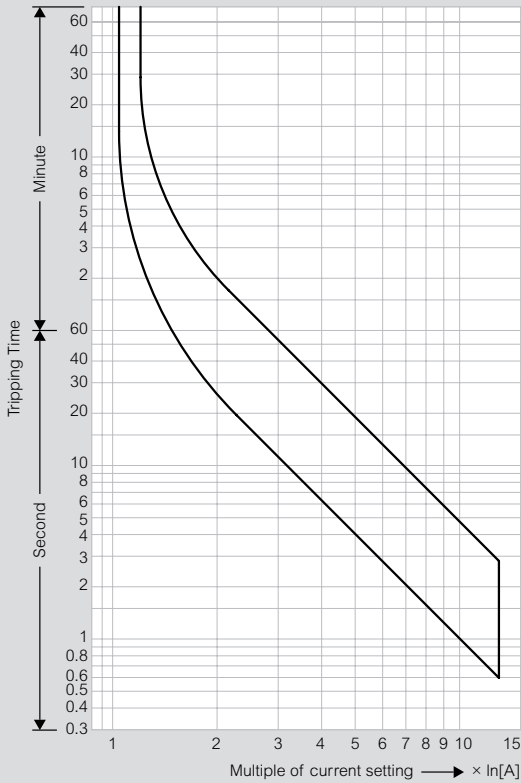

Hot starting

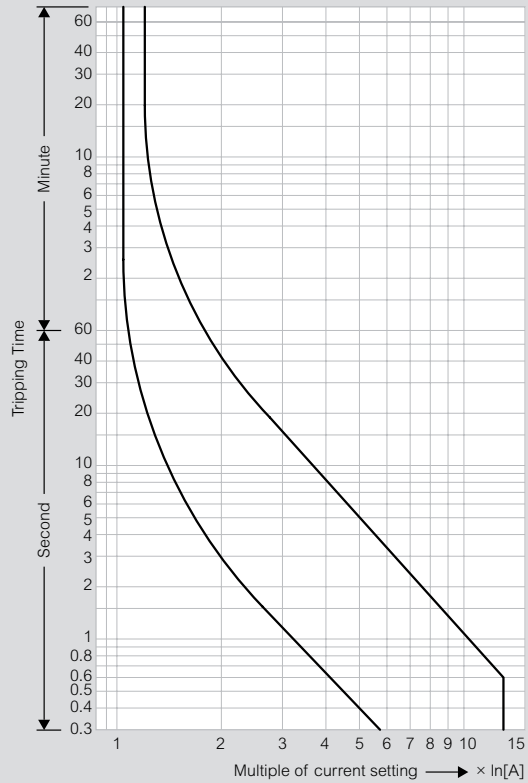

RTX³ mini - class 10 A (thermal relays for CTX³ mini contactors)

Cold starting

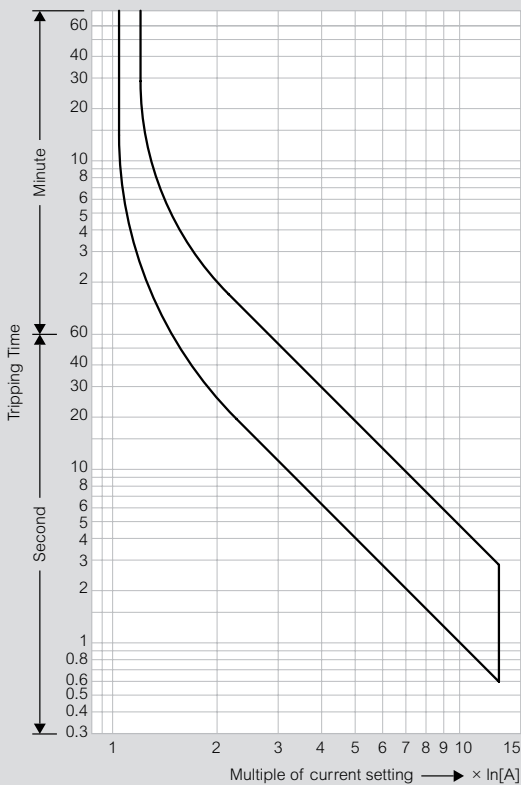

Hot starting

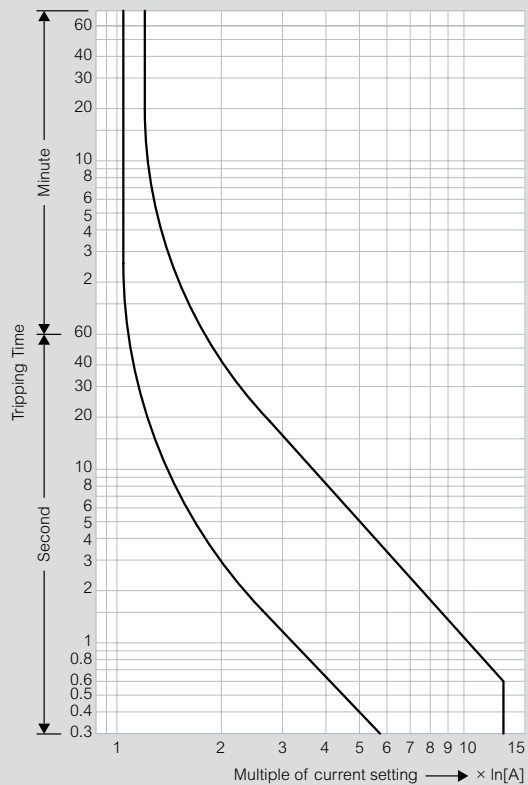

Tripping curves

MPX³ 32S / 32H / 32MA

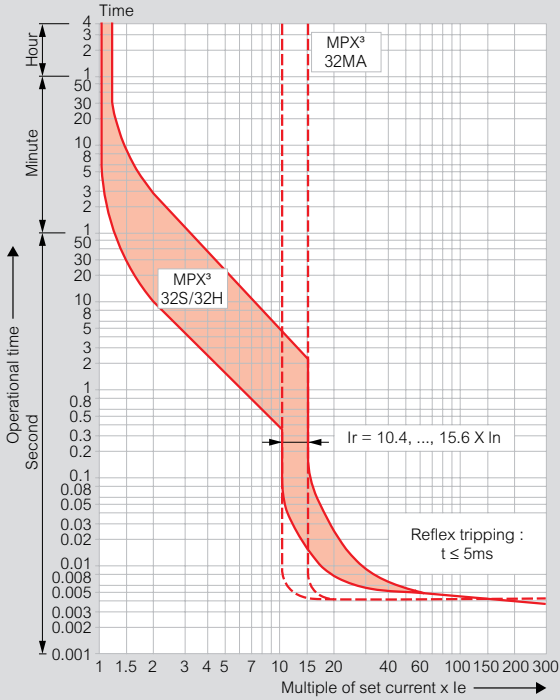

MPX³ 63H / 100H

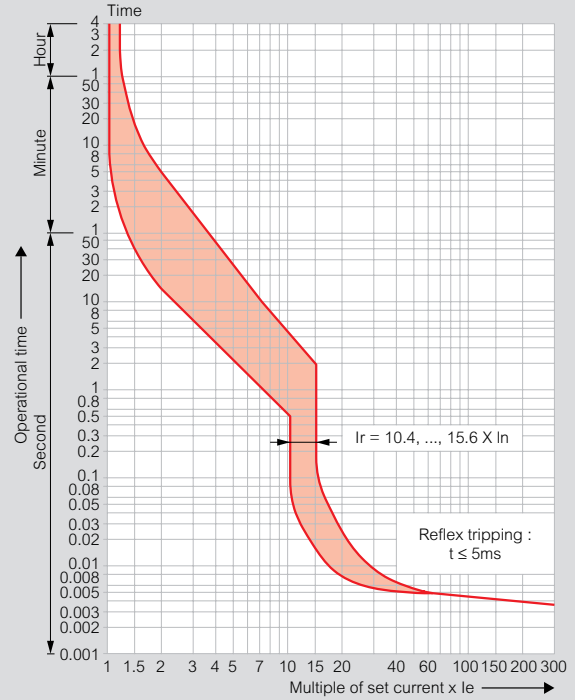

1) Thermal release trip current :

The adjustable inverse bimetal trip reliability protects motors against overloads.
The curve shows the mean operating current at an ambient temperature of 20 °C starting from cold.
Careful testing and setting ensures effective motor protection even in the case of single-phasing.

2) Magnetic release trip current :

The instantaneous magnetic trip has a fixed operating current setting.
This corresponds to 13 times the maximum value of setting range, at a lower setting it is correspondingly higher.

3) Current setting I_e :

The overload trip corresponds to a thermal overload relay in a motor starter conforming to IEC 947-4-1.
If a different value is prescribed (e.g. reduced I_e for cooling medium having a temperature higher than 40 °C or a place of installation higher than 2000m above sea level), the setting current is equal to the reduced rated current I_e of the motor.

MPCBs MPX³

curves (continued)

■ Thermal limit in kA²s in the magnetic operating zone (U_e = 415 V)

MPX³ 32S / 32H / 32MA

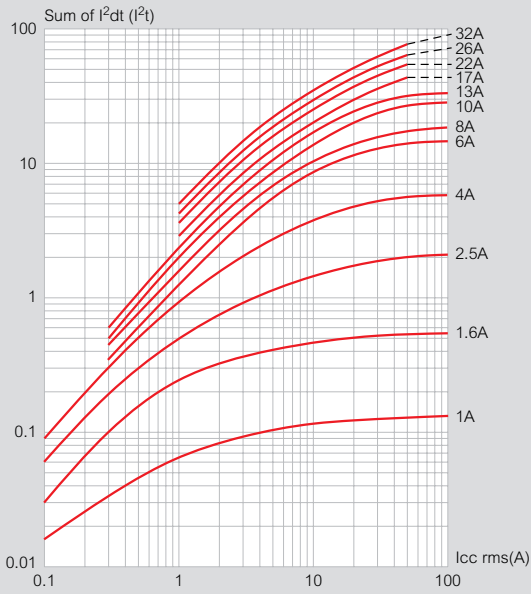

MPX³ 63H / 100H

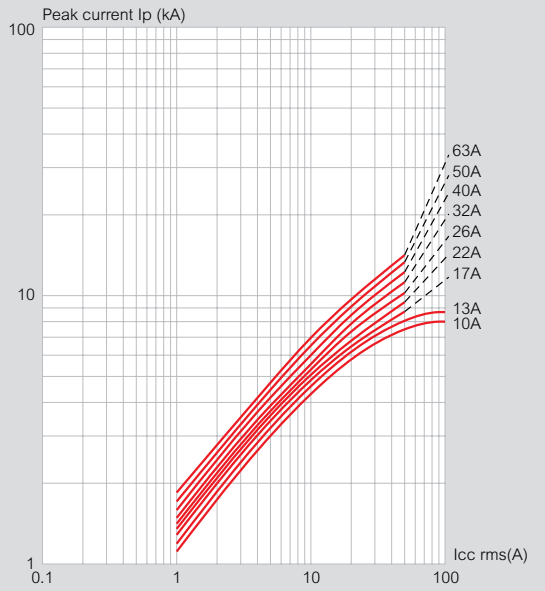
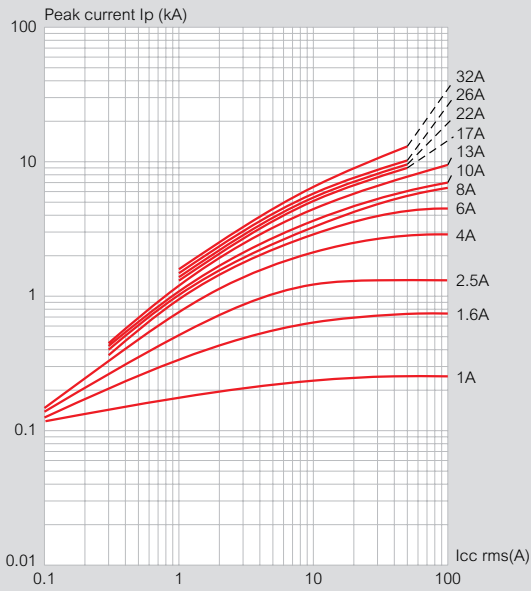
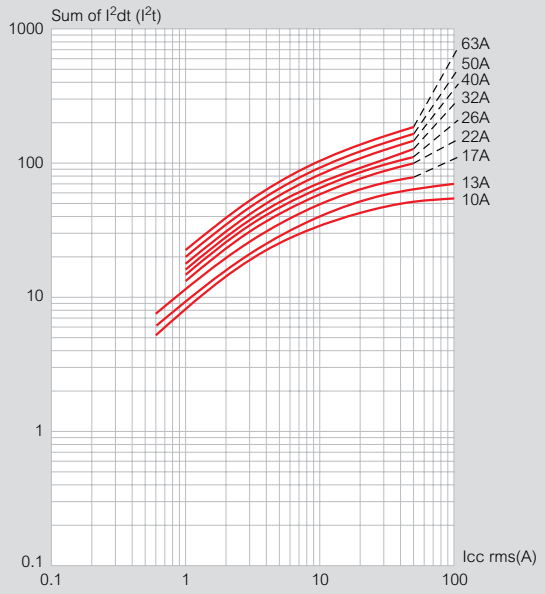

Mini contactors CTX³

technical characteristics and dimensions

Mini contactors 3P and 4P and control relays

AC control

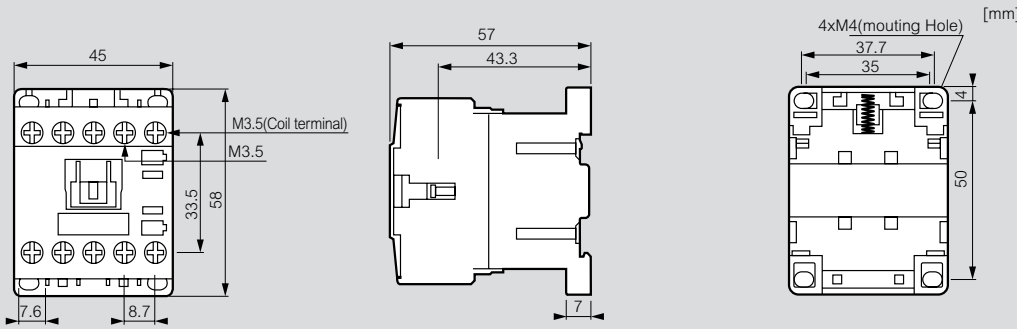

DC control

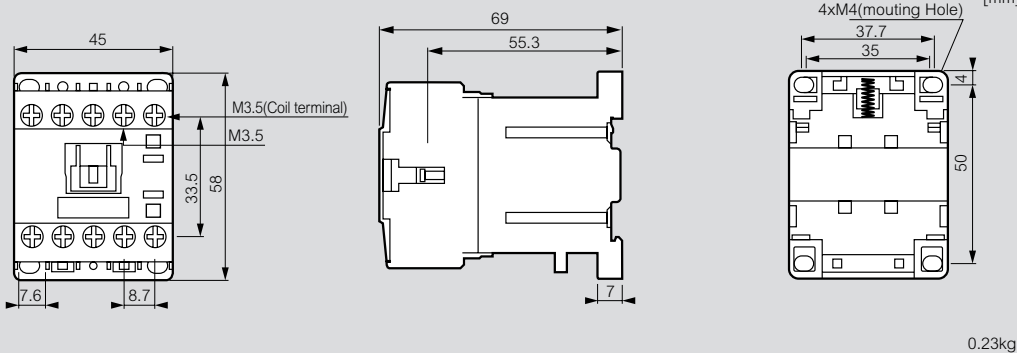

Thermal overload relays for mini contactors

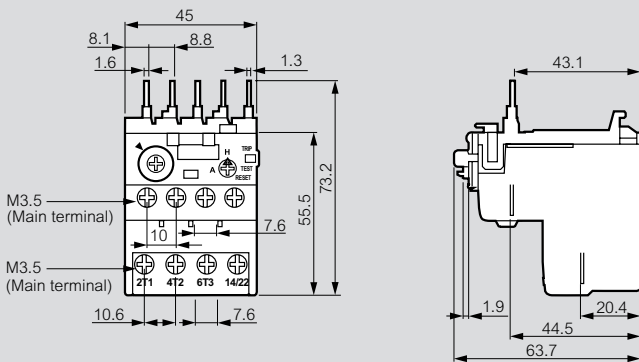

Auxiliary contacts

Front mounting

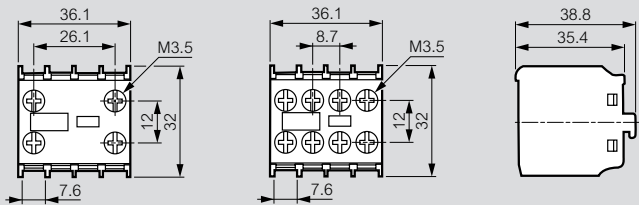

Side mounting

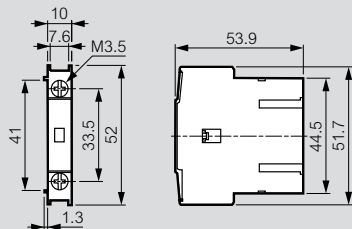

3-pole contactors CTX³

dimensions

CTX³ 22

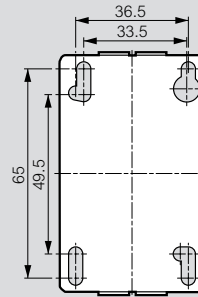
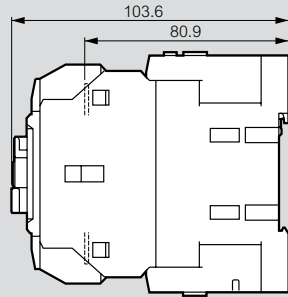
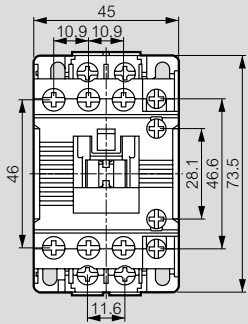

CTX³ 40

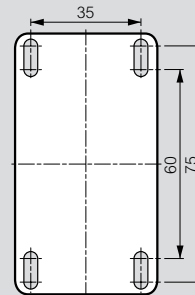
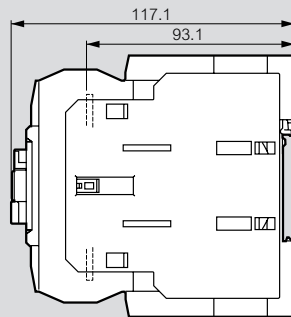
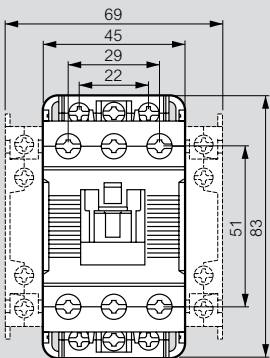

CTX³ 65

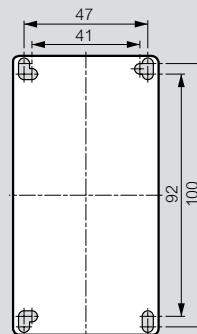
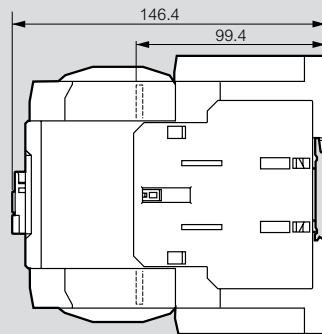
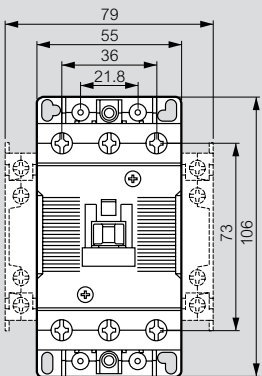

CTX³ 100

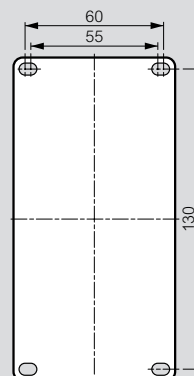
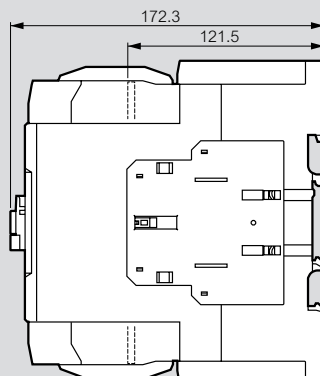
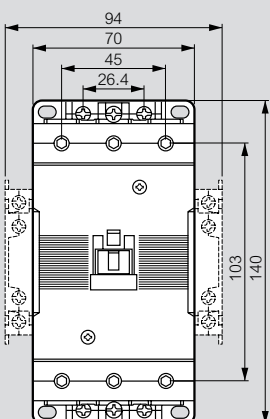

3-pole contactors CTX³

dimensions (continued)

CTX³ 150

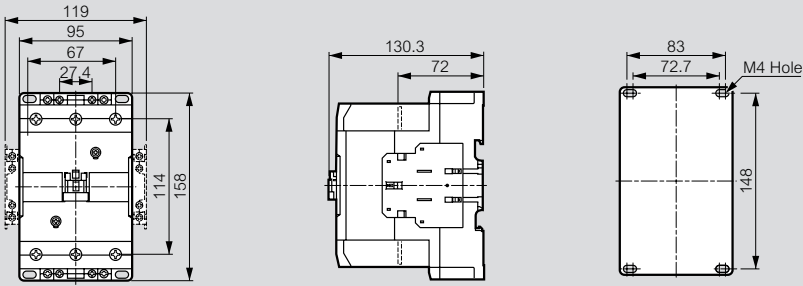

CTX³ 225

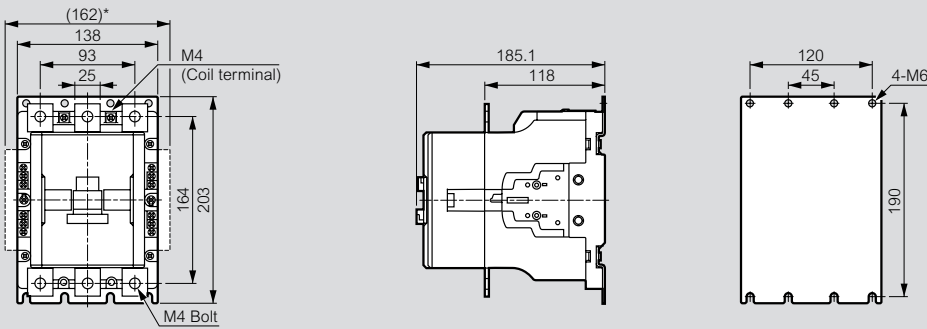

CTX³ 400

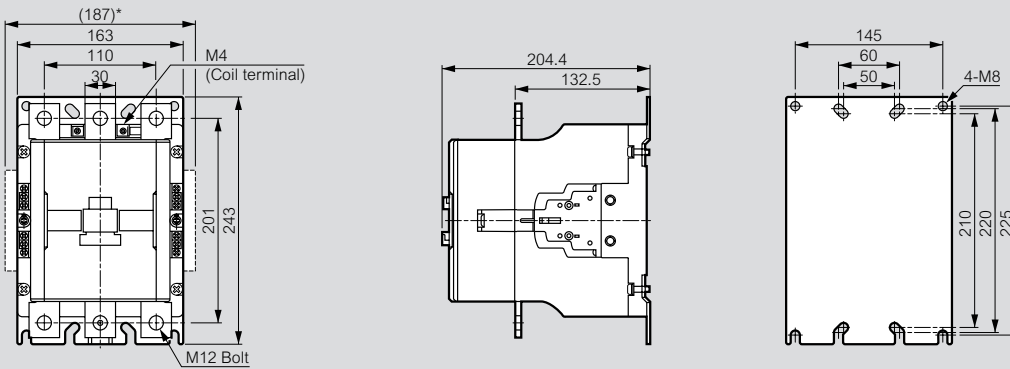

CTX³ 800

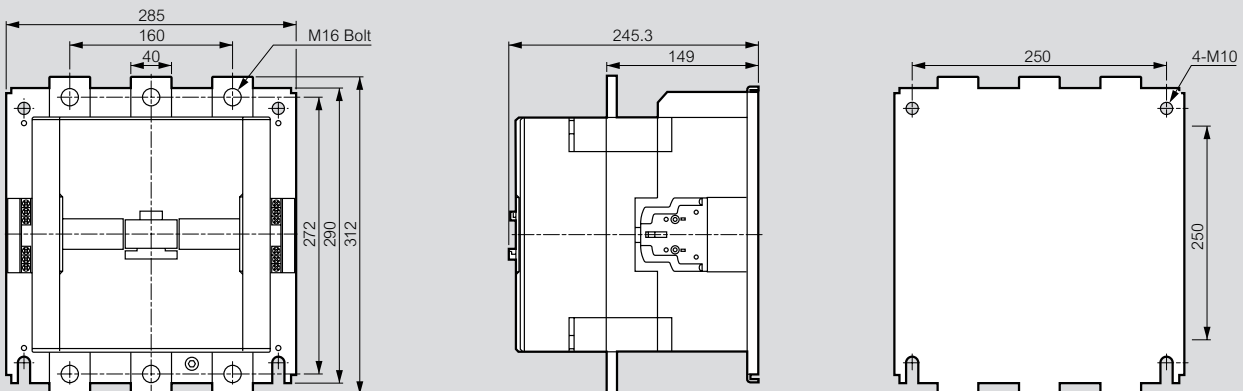

4-pole contactors CTX³

dimensions

CTX³ 4P 40 A

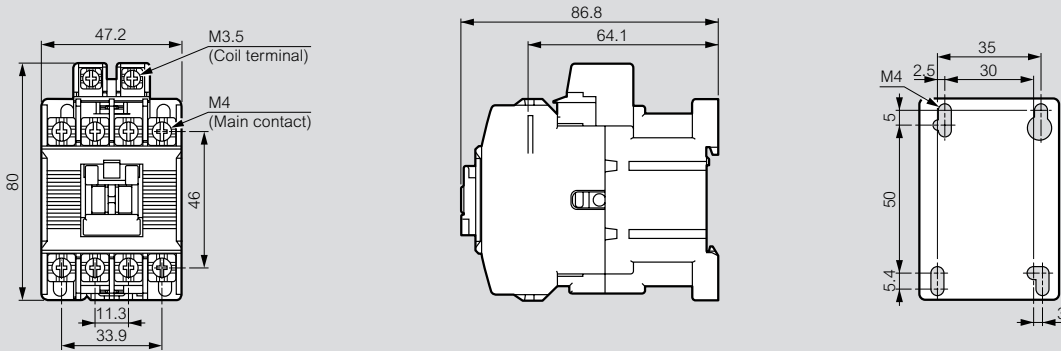

CTX³ 4P 60 A

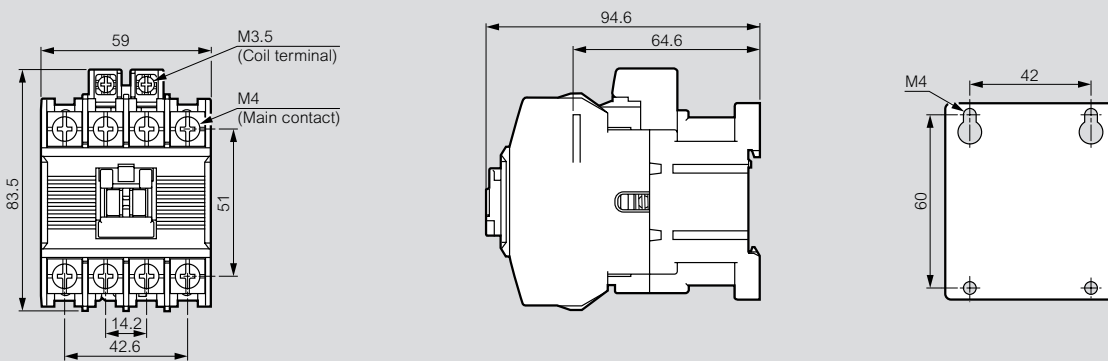

CTX³ 4P 100 A and 135 A

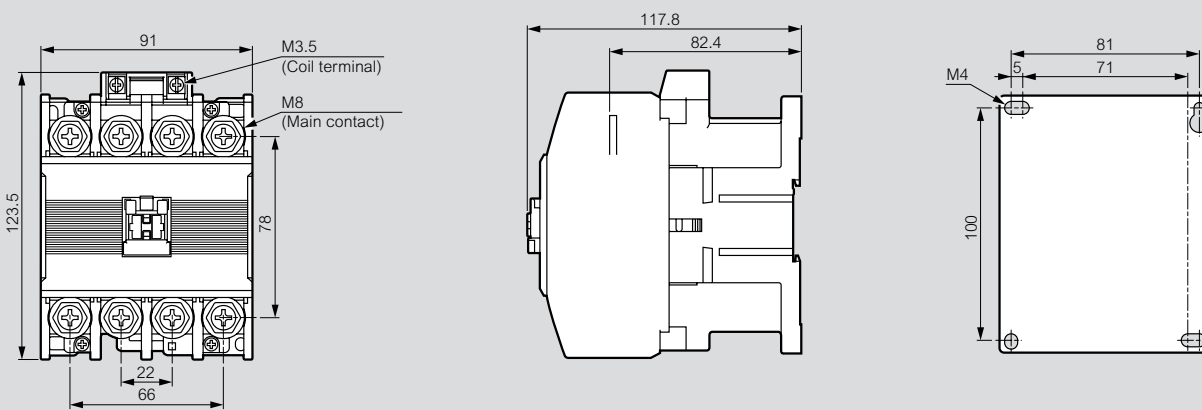

CTX³ 4P 165 A, 250 A and 330 A

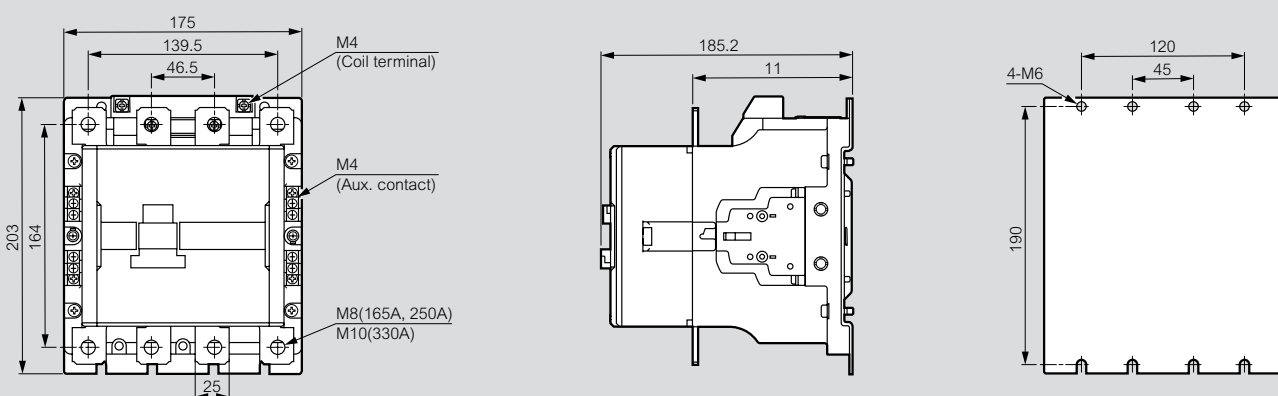

4-pole contactors CTX³

dimensions (continued)

CTX³ 4P 420 A and 500 A

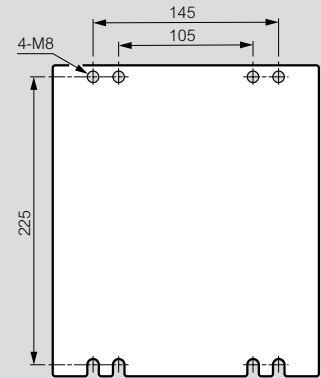
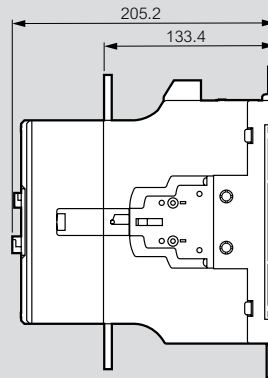
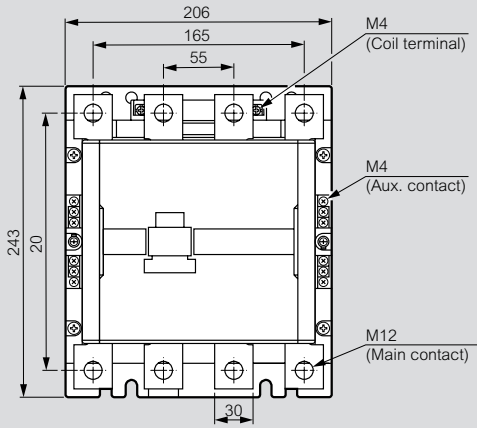

CTX³ 4P 750 A and 900 A

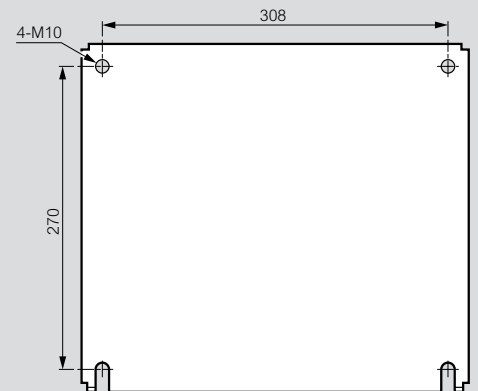
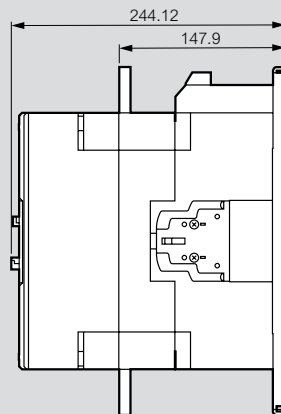
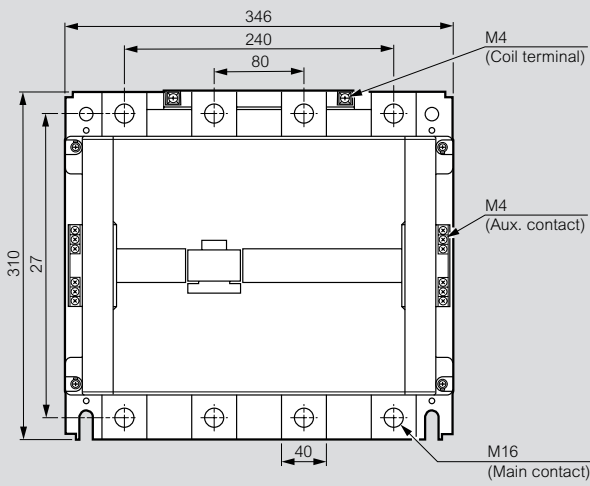

CTX³ accessories

dimensions and wiring diagrams

Auxiliary contacts for CTX³

Front mounting

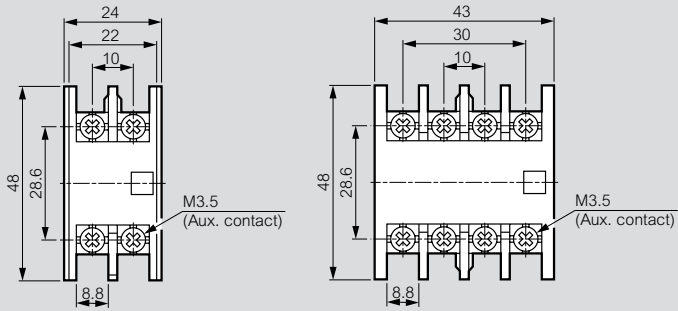

Side mounting

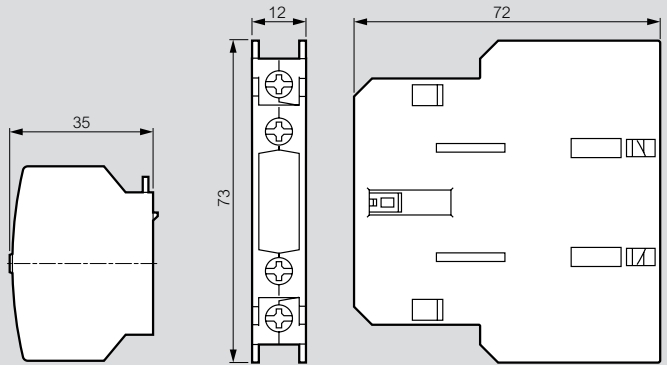

CTX³ time-delay blocks

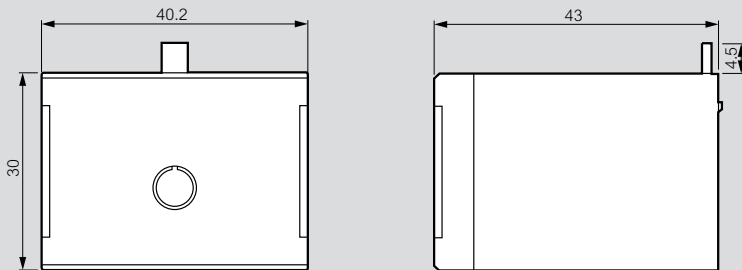

ON delay - Cat.Nos 4168 70/71

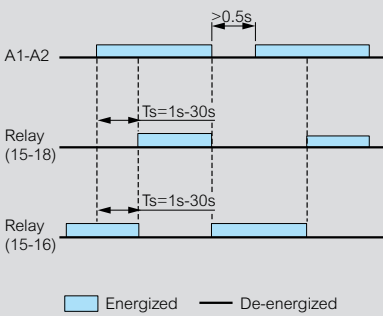

Circuit diagram

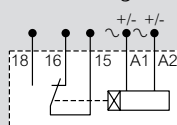

OFF delay - Cat.Nos 4168 72/73

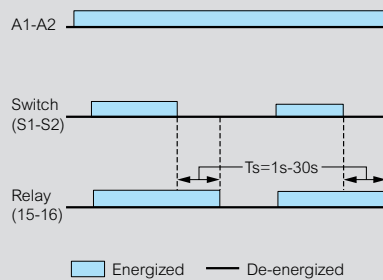

Circuit diagram

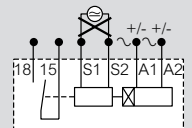
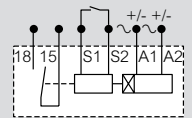

Thermal relays RTX³ - screw type terminals and cage terminals

dimensions

RTX³ 40

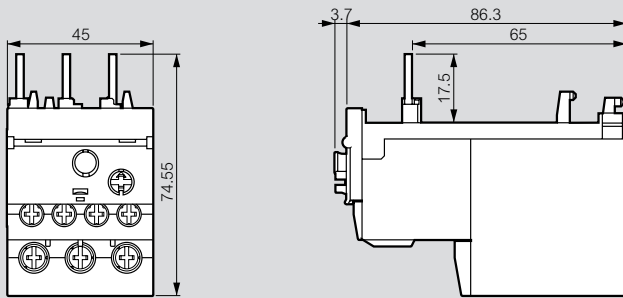

RTX³ 65

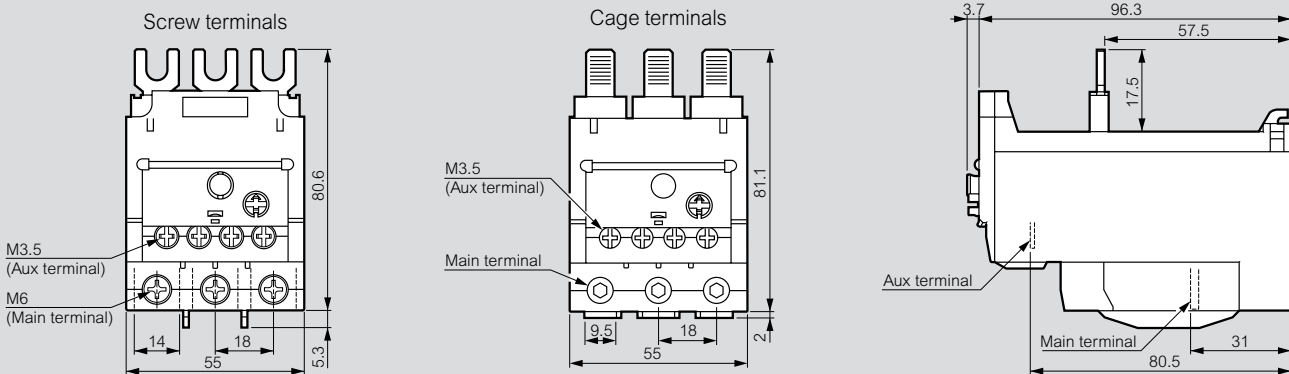

RTX³ 100

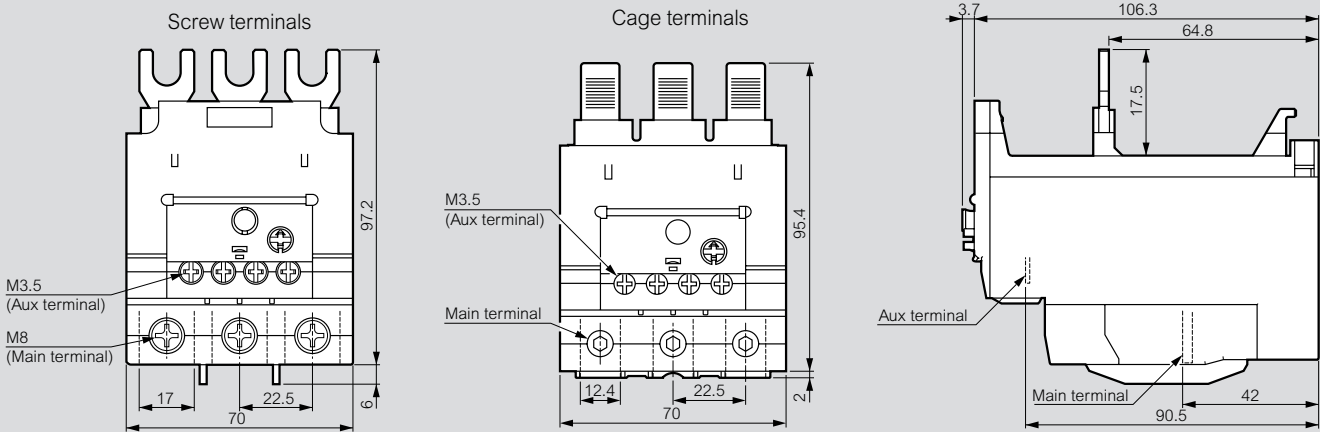

RTX³ 150

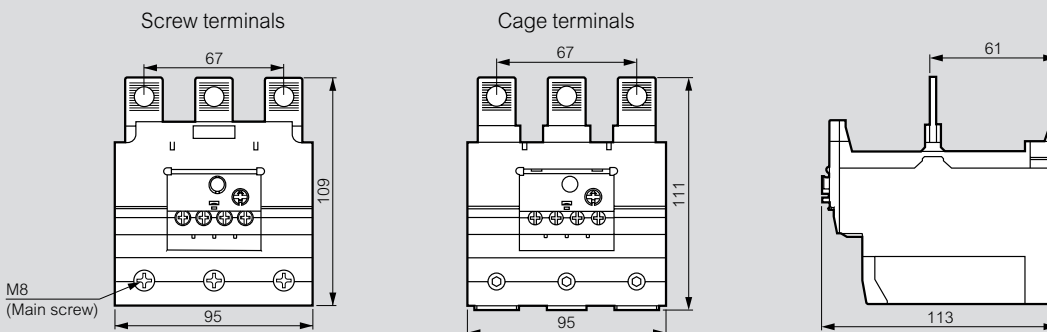

Thermal relays RTX³ - screw type terminals and cage terminals

dimensions (continued)

RTX³ 225

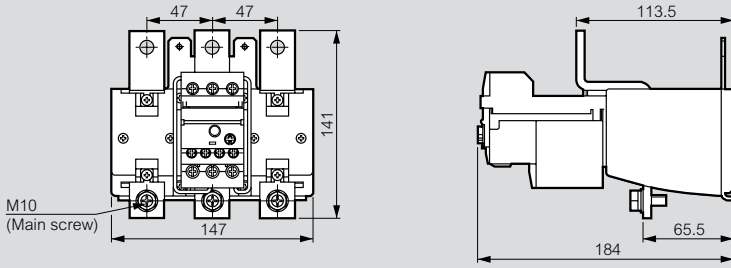

RTX³ 400

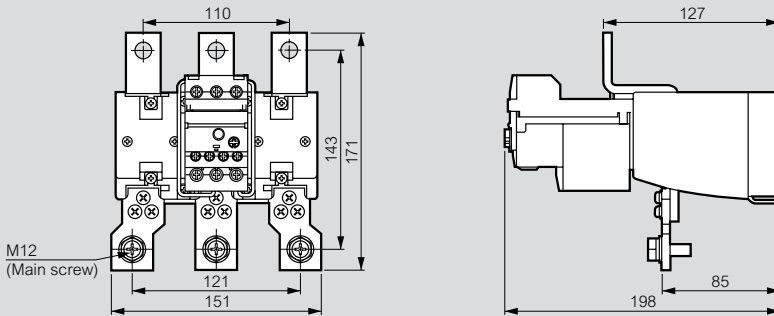

RTX³ 800

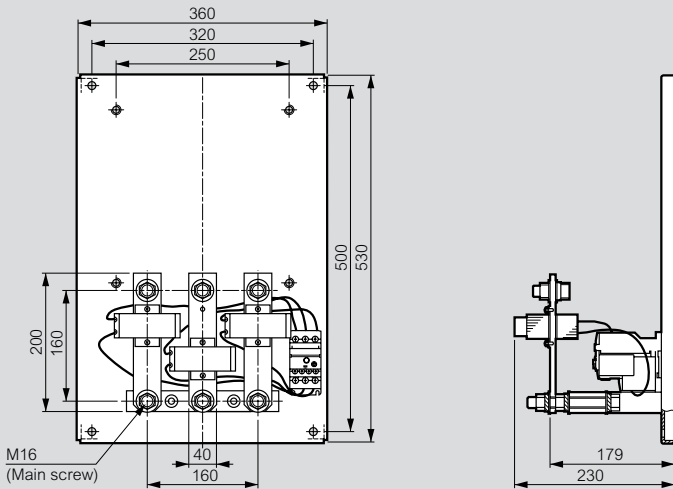

MPCBs MPX³

dimensions

MPX³ 32S

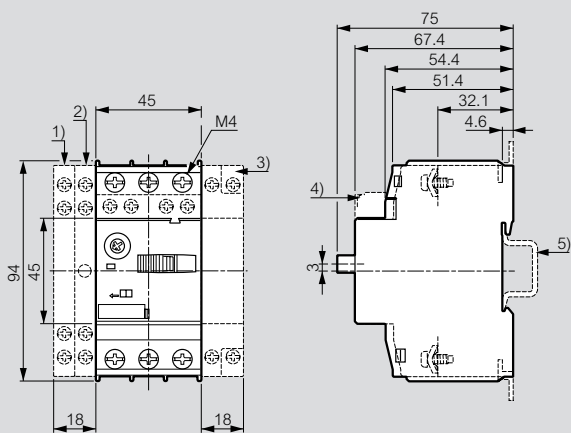

Weight: 0.320 kg

- 1) Side auxiliary contact
- 2) Side magnetic trip alarm contact
- 3) Side shunt release or Side undervoltage release
- 4) Front auxiliary contact
- 5) 35 mm standard mounting rail acc. to EN 50 022

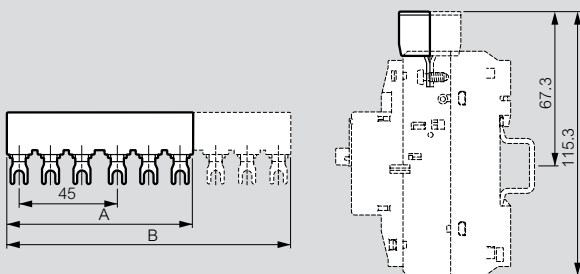

Cat.Nos	Numbers of MPX ³	A ⁽¹⁾ (mm)	B (mm)
4174 71	2	85	-
4174 73	3	-	130
4174 75	4	-	175
4174 76	5	-	220

(1) Only for Cat.No 4174 71

MPX³ 32H / 32MA

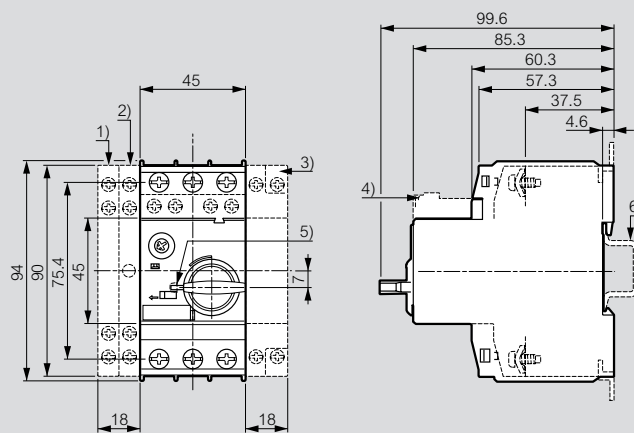

Weight: 0.360 kg

- 1) Side auxiliary contact
- 2) Side magnetic trip alarm contact
- 3) Side shunt release or Side undervoltage release
- 4) Front auxiliary contact
- 5) Handle lock in OFF position (Ø 5 mm)
- 6) 35 mm standard mounting rail acc. to EN 50 022

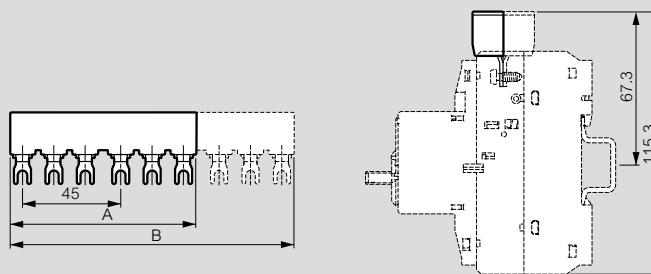

Cat.Nos	Numbers of MPX ³	A ⁽¹⁾ (mm)	B (mm)
4174 71	2	85	-
4174 73	3	-	130
4174 75	4	-	175
4174 76	5	-	220

(1) Only for Cat.No 4174 71

MPCBs MPX³

dimensions (continued)

MPX³ 63H

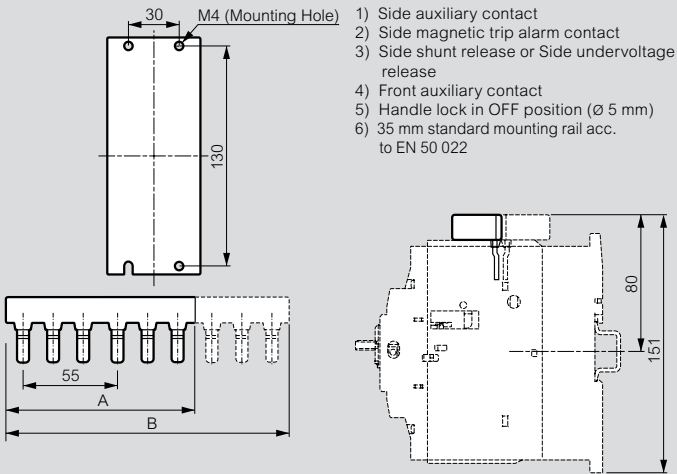
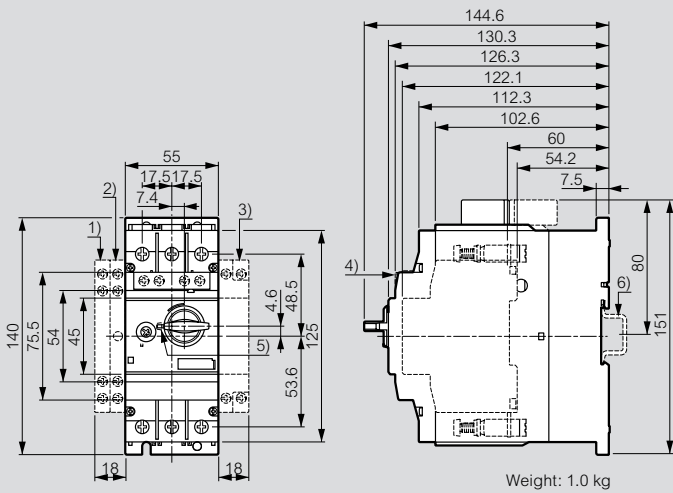

Cat.Nos	Numbers of MPX ³	A ⁽¹⁾ (mm)	B (mm)
4174 72	2	110	-
4174 74	3	-	165

(1) Only for Cat.No 4174 72

MPX³ 100H

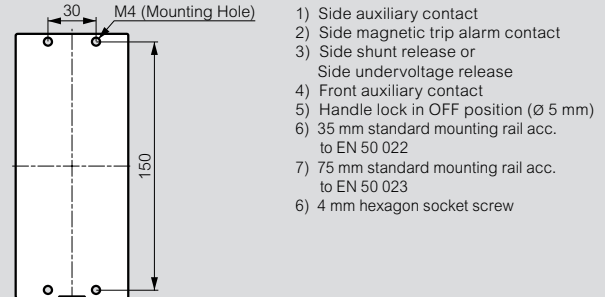
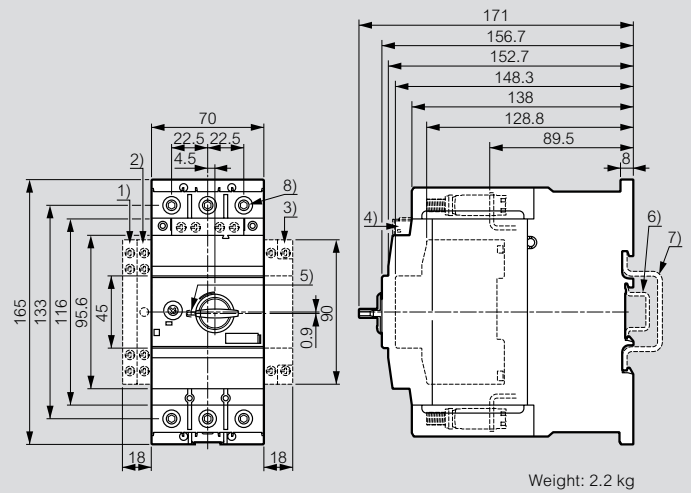

Contactors CTX³

dimensions

Overall dimensions of contactors equipped with CTX³ switching units

Cat.No 4168 74 on CTX³ 22

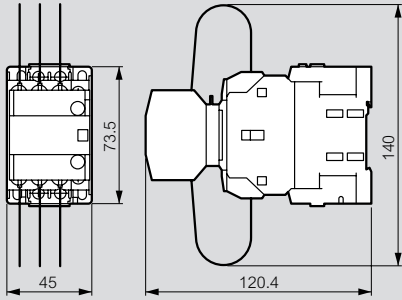

Cat.No 4168 75 on CTX³ 65

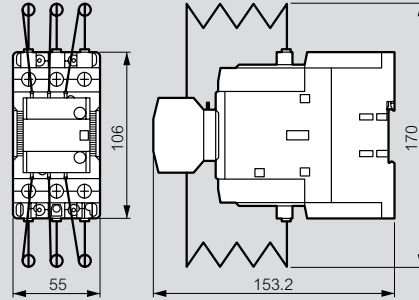

Cat.No 4168 74 on CTX³ 40

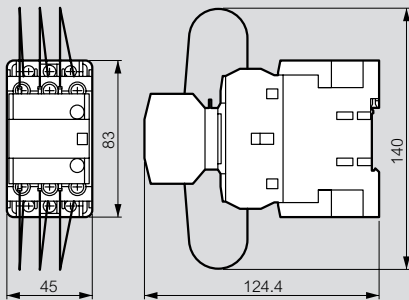

Cat.No 4168 77 on CTX³ 100

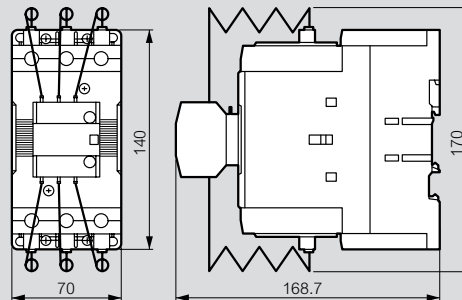

MPCBs MPX³

dimensions (continued)

External Handle

MPX³ 32H / 32MA - Cat.No 4174 63

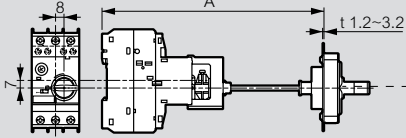

MPX³ 63H - Cat.No 4174 64

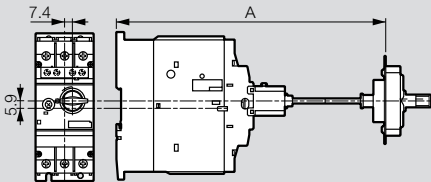

MPX³ 100H - Cat.No 4174 65

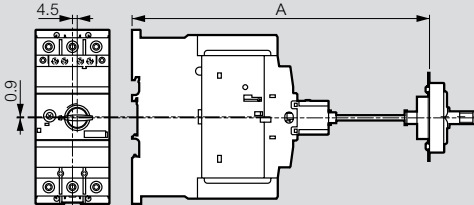

Cat.Nos	A (mm)	MMS Type
4174 63	min: 148.6	MPX ³ 32H / 32MA
	max: 410.6 (Shaft 315mm)	
4174 64	min: 193.6	MPX ³ 63H
	max: 455.6 (Shaft 315mm)	
4174 65	min: 220	MPX ³ 100H
	max: 482 (Shaft 315mm)	

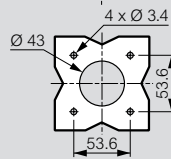

Enclosure

Cat.Nos 4174 80/81

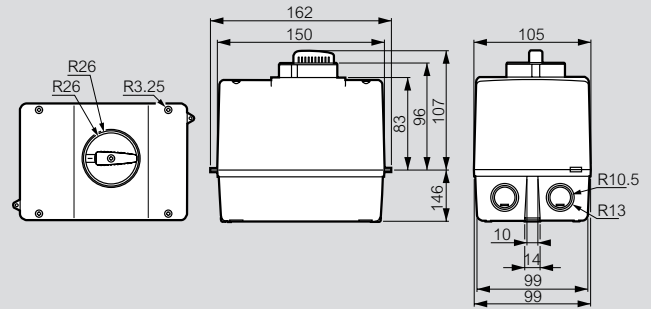

Phase Bus

Cat.Nos 4174 71/73/75/76

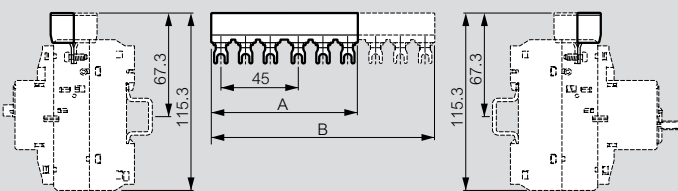

Cat.Nos 4174 72/74

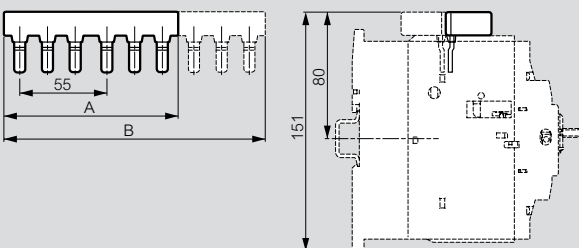

Cat.Nos	Number of MPX ³	A (mm)	B (mm)
4174 71	2	85	-
4174 72	3	-	130
4174 73	2	110	-
4174 74	3	-	165
4174 75	4	-	175
4174 76	5	-	220

CTX³ accessories

dimensions and wiring diagrams (continued)

Boxes for motor starters

Without pushbuttons - Cat.No 4168 90

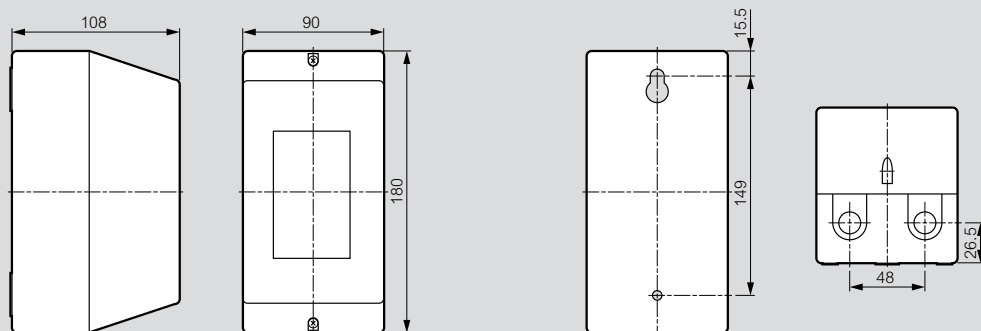

With pushbuttons - Cat.No 4168 91

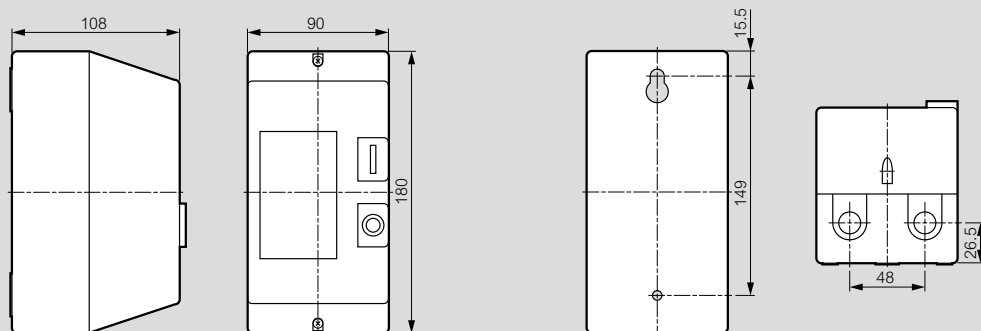

Wiring diagram - Cat.No 4168 90

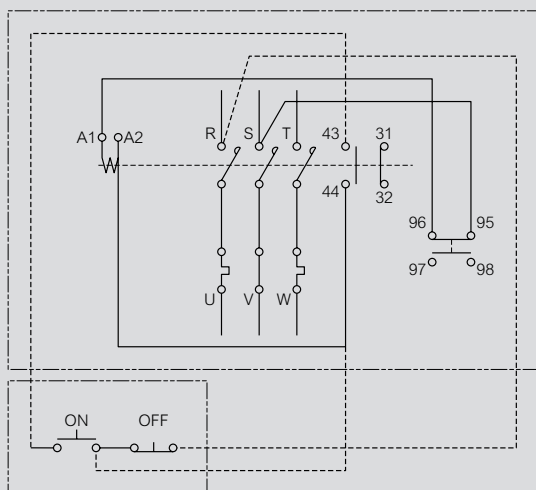

Wiring diagram - Cat.No 4168 91

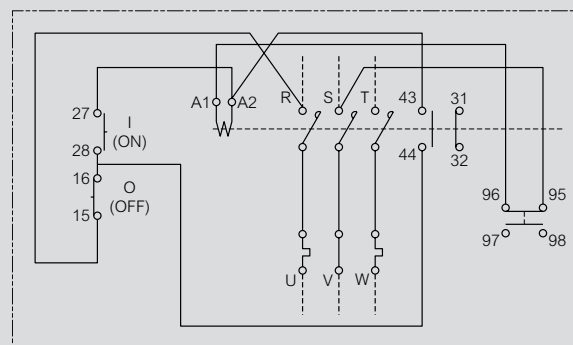

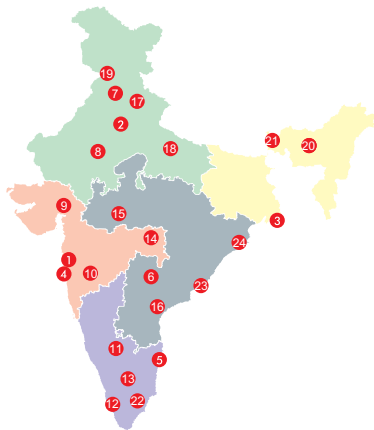

Head office

- 61 & 62, 6th Floor,
Kalpataru Square, Kondivita Road,
Off Andheri-Kurla Road, Andheri (E),
MUMBAI - 400 059.
Tel : (022) 3041 6200
Fax : (022) 3041 6201
Website : www.legrand.co.in

Regional sales offices

- A-25, Mohan Co-operative
Industrial Estate, Mathura Road,
NEW DELHI - 110 044.
Tel : (011) 2699 0028 / 29 / 30, 3990 2200
Fax : (011) 2699 0047
- Bhakta Towers, 2nd & 3rd Floor,
Plot No. KB 22, Salt Lake, Sector - 3,
KOLKATA - 700 098.
Tel : (033) 4021 3535 / 36
Fax : (033) 4021 3537
- 34, 3rd Floor, Kalpataru Square,
Kondivita Road, Off Andheri-Kurla Road,
Andheri (East),
MUMBAI - 400 059.
Tel : (022) 3385 6200
Fax : (022) 3385 6201
- Gee Gee Universal,
8th Floor, Door No. 2, 18/1 & 18/2,
McNichols Road, Chetput,
CHENNAI - 600 031.
Tel : (044) 3024 7200, 2836 4165 / 67 / 68
Fax : (044) 2836 4169
- 205-208, 2nd Floor, Block - II,
White House, Kundan Bagh, Begumpet,
HYDERABAD - 500 016.
Tel : (040) 2341 4398 / 67, 4567 1717
Fax : (040) 6636 6974

Branch offices

- SCO 1-2-3,
Second Floor, Sector 17B,
CHANDIGARH - 160 017.
Tel : (0172) 305 8631 / 32 / 33 / 34 / 35
Fax : (0172) 501 9008
- 507-510, Vth Floor, Soni Paris Point,
Jai Singh Highway, Banipark,
JAIPUR - 302 016.
Telefax : (0141) 511 3129
- 504, Sakar IV,
Opp. M. J. Library, Ellis Bridge,
AHMEDABAD - 380 006. Gujarat
Tel : (079) 2658 6561 / 2
Fax : (079) 2658 6563
- 402, Swastik Chambers,
Near Ashwamegh Marriage Hall,
Behind HP Petrol Pump,
Off Karve Road, Erandwane,
PUNE - 411 004.
Tel : (020) 6729 5600 / 601
Fax : (020) 6729 5604
- 11nd Floor, Al-Latheef Building,
2/1, Union Street, Off. Infantry Road,
BANGALORE - 560 018.
Tel : (080) 2286 1081, 4113 3293 / 4
Fax : (080) 2286 1078
- No. 36/2178, Syda Building, 2nd Floor,
Kaloor - Kadavanthra Road, Kaloor,
KOCHI - 682 017.
Tel : (0484) 234 2921, 658 0921
Fax : (0484) 233 3921
- B-15, Thirumalai Towers,
IV-D, Fourth Floor,
723, Avanasli Road,
COIMBATORE - 641 018.
Tel : (0422) 650 2728, 222 3634 / 0283
Fax : (0422) 222 3164
- Plot No.95, II Floor, Shreyash Heights,
Ramdas Peth, VIP Road,
NAGPUR - 440 010.
Tel : (0712) 662 7857 / 58
Fax : (0712) 662 7859
- 204-205, Megapolis Square,
579, M G Road,
INDORE - 452 001.
Tel : (0731) 393 1650 / 51 / 52
Fax : (0731) 393 1653
- MF-2, Datta's Lords House,
Jammi Chettu Street,
VIJAYAWADA - 520 010.
Tel : (0866) 661 1393, 664 6393
Fax : (0866) 669 9393

Area offices

- ABC Business Club 16,
Tagore Villa,
Chakrata Road,
DEHRADUN - 248 001.
Uttaranchal.
Tel : (0135) 271 5189 / 248 001
- Cabin No.104/105,
Trade Point,
Ground Floor,
Saran Chamber 1,
5, Park Road, Hazratganj,
LUCKNOW - 226 001.
Tel : (0522) 223 9044 / 7285
Fax : (0522) 223 9124
- Cabin No. 9,
Second Floor,
Madhok Trade Centre,
Madhok Complex,
Ferozpur Road,
LUDHIANA - 141 001.
Tel/Fax No.: (0161) 277 0301 / 304
- House No. 97,
Ground Floor,
Rajgarh Main Road,
Opp. City Heart Nursing Home,
GUWAHATI - 781 007.
Tel : (0361) 245 8498
- 94, Udham Singh Sarani,
Ground Floor, Ashrampara,
SILIGURI - 734 001.
Tel : 94341 91635 / 98009 77780
- Aparna Towers, 1st Floor,
2/3, Bypass Road,
MADURAI - 625 010.
Telefax : (0452) 230 8414
- 404, Eshwar Plaza,
Dwaraka Nagar, Main Road,
VISHAKHAPATNAM - 530 020.
Tel : (0891) 663 5652
Fax : (0891) 663 9363
- Plot No. 359,
Saheed Nagar, 2nd Floor,
BHUBANESWAR - 751 007.
Tel : (0674) 254 0623

Technical assistance from Legrand

Telephonic technical assistance for selection of products, technical information, guidance, wiring diagrams and estimation is now made available to you at each Regional Office. Contact the Technical Officer of Legrand at the following telephone numbers

- New Delhi** : Tel.: (011) 2699 0028, 3990 2200
Kolkata : Tel.: (033) 4021 3535 / 36
Mumbai : Tel.: (022) 3385 6200
Chennai : Tel.: (044) 3024 7200, 2836 4165 / 67 / 68
Hyderabad : Tel.: (040) 2341 4398 / 67, 4567 1717

For other places, contact the nearest
Regional / Branch / Area offices

customer.care@legrand.co.in

