



MVAJM

High Speed Tripping and Control Relays

Models available

Type MVAJM relays may broadly be divided into three groups:

- High burden tripping relays
- Low burden tripping relays
- Control relays

Application

High burden tripping relays: Types MVAJM 15, 25, 41, 45

These relays are suitable for use in high security circuit breaker tripping circuits. In particular they can be used in distributed tripping or control relay contact logic schemes where the initiating contact may be remote from the relay. The high burden provides immunity to capacitance discharge currents, which can result at the inception of an earth fault on battery wiring and immunity to the subsequent leakage current. The high burden relays are recommended for use with series connected operation indicators, supervision relays and series seal-in units on protective relays.

Low burden tripping relays: Types MVAJM 11, 13

These relays are suitable for applications where immunity to capacitance discharge and high minimum operation current are not required. These relays are generally used when a number of simultaneous operations are to be initiated by a single protective relay having insufficient contacts of its own and where series connected operation indicators are not used.

Control relay: Type MVAJM 14

This is an electrically reset control relay. The relay is meant for switching the secondary circuits of current transformer in busbar protection. Also wherever "latch-in" type of control relay is required for contact multiplication control schemes, relay type MVAJM 14 can be employed.

Features

- High speed operation
- High degree of mechanical stability
- Positive action without chatter
- Proof against high capacitance discharge currents

Customer Benefits

- Directly operates circuit breaker trip coils
- High reliability
- High speed operation
- Immunity to wiring capacitance discharge



Technical data

Coil rating

Refer Table 2.

Voltage band for satisfactory operation

50% to 120% of rated voltage for trip relays. 75% to 120% for MVAJM 14.

Operating time

10 millisecs nominal at rated voltage

Contacts

The number of contacts available is shown in Table 2.

Insulation

The relay meets the requirements of IS 3231 - 1965/IEC/255-5 Series C- 2KV for 1 minute.

Thermal rating

Relays with hand reset contacts:Relay coil short time rated. Hand reset coil cut off contact provided in series with operating coil.

Relays with self reset contacts:120% of rated voltage, continuous.

Burden

Refer Table 2.



Table 1 lists the general characteristics and includes information on how the relay burden is modified at or just after operation. 'Economy' indicates that the burden is reduced to a low value. Instantaneous cut-off is a feature of some hand and electrically reset elements and reduces the burden to zero.

| S.No | Relay type | Contact mechanism | Operator indicator facility | Cut-off | Group | Case size |
|------|------------|-------------------|-----------------------------|---------------|-------------|-----------|
| 1 | MVAJM 11 | S/R | Available (H/R) | | Low burden | Size 2 |
| 2 | MVAJM 13 | H/R | Available (H/R) | Instantaneous | Low burden | Size 2 |
| 3 | MVAJM 14 | E/R | Available (H/R) | Instantaneous | Low burden | Size 4 |
| 4 | MVAJM 15 | H/R | Available (H/R) | Instantaneous | High burden | Size 2 |
| 5 | MVAJM 25 | H/R | Available (H/R) | Instantaneous | High burden | Size 4 |
| 6 | MVAJM 41 | S/R | Available (H/R) | Economy | High burden | Size 6 |
| 7 | MVAJM 45 | H/R | Available (H/R) | Instantaneous | High burden | Size 8 |

KEY: i) S/R: Self reset ii) H/R: Hand reset iii) E/R: Electrical reset

Cases

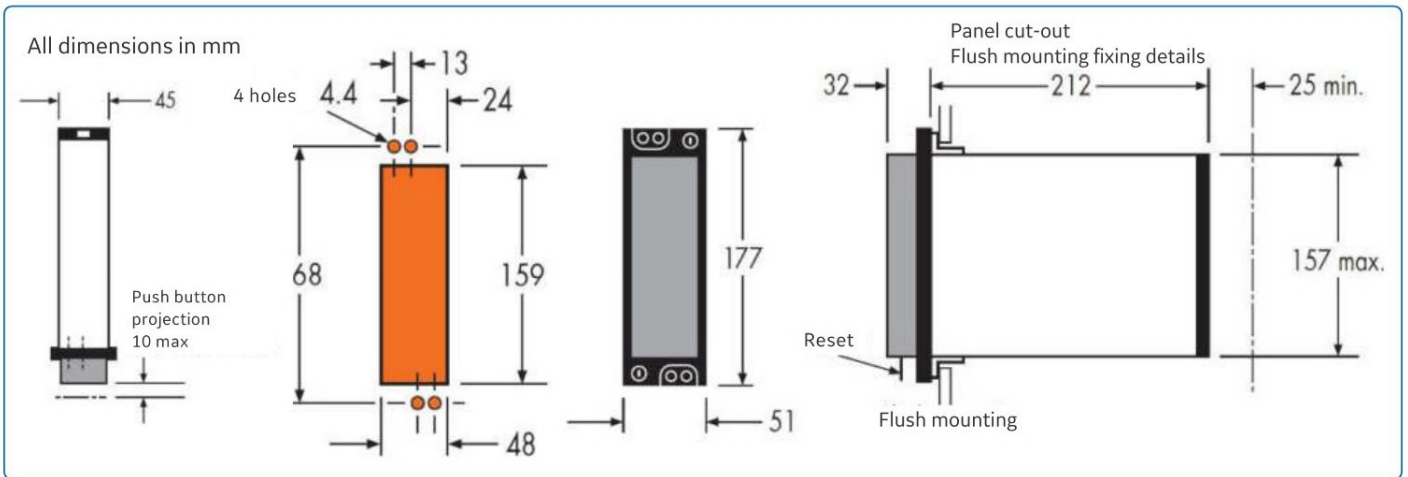

Figure : Case Outline Size 2

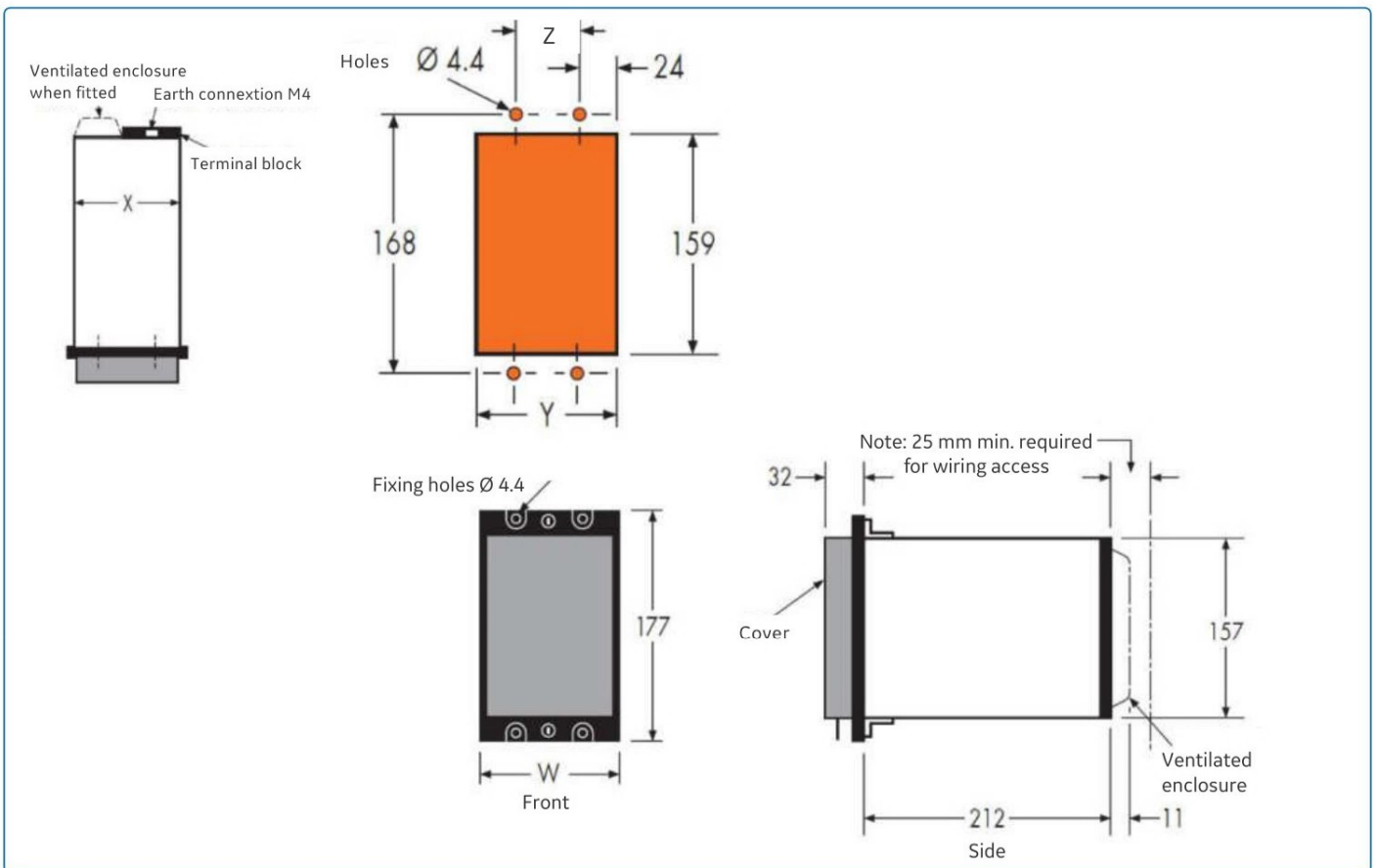

Figure: Case and panel cut-out dimensions for relay case sizes 3 to 16

Case size in mm

| Dimensions | 3 | 4 | 6 | 8 | 16 |
|------------|----|-----|-----|-----|-----|
| Dimensions | 3 | 4 | 6 | 8 | 16 |
| w | 77 | 103 | 155 | 206 | 414 |
| x | 71 | 97 | 149 | 200 | 408 |
| y | 73 | 99 | 151 | 203 | 411 |

Characteristics

| S.No | Relay type | Standard coil rating | No of output contacts | Standard contact configuration | Burden |
|------|------------|-----------------------|-----------------------|--------------------------------|---------|
| 1 | MVAJM 11 | 100/125 V dc | 4 | 4M | 14/16 W |
| | | 200/250 V dc | 4 | 4M | 28/47 W |
| 2 | MVAJM 13 | 100/125 V dc | 4 | 2M+2B, 3M+1B | 18 W |
| | | 200/250 V dc | 4 | 2M+2B, 3M+1B | 37 W |
| 3 | MVAJM 14 | 30 V dc | 8 | 5M+3B | 20 W |
| | | 100/125, 200/250 V dc | 8 | 8M 5M+3B, 4M+4B, 3M+5B | 20 W |
| 4 | MVAJM 15 | 100/125, 200/250 V dc | 4 | 4M 3M+1B 2M+2B | 150 W |
| 5 | MVAJM 25 | 100/125, 200/250 V dc | 8 | 6M+2B | 150 W |
| 6 | MVAJM 41 | 100/125, 200/250 V dc | 13 | 13M | 150 W |
| 7 | MVAJM 45 | 100/125, 200/250 V dc | 16 | 13M+3B | 150 W |

KEY: M - Make B - Break

Note: Other contact configurations are also available on request.

Contact Ratings

| | Make and carry continuously | Make and carry for 3 Seconds | Break |
|----|--------------------------------------|---------------------------------------|--|
| AC | 1250 VA with maxima of 5 A and 660 V | 7500 VA with maxima of 30 A and 660 V | 1250 VA with maxima of 5 A and 660 V |
| DC | 1250 W with maxima of 5 A and 660 V | 7500 W with maxima of 30 A and 660 V | 100 W (resistive) 50 W (inductive) with maxima of 5 A and 660 V |

Information Required with Order

1. Type of relay
2. Coil voltage rating
3. Number of 'make' and 'break' contacts
4. Whether operation indicator required
5. Case size

For more information please contact
GE
Grid Solutions

Worldwide Contact Center

Web: www.GEGridSolutions.com/contact
Phone: +44 (0) 1785 250 070

GEGridSolutions.com

IEC is a registered trademark of Commission Electrotechnique Internationale.

GE and the GE monogram are trademarks of General Electric Company.

GE reserves the right to make changes to specifications of products described at any time without notice and without obligation to notify any person of such changes.

MVAJM-Brochure-EN-2020_06-Grid-GA-1694. © Copyright 2020, General Electric Company. All rights reserved.



Imagination at work